



NBS TECHNICAL NOTE 662

U. S. DEPARTMENT OF COMMERCE / National Bureau of Standards

A Review of Precision Oscillators

NATIONAL BUREAU OF STANDARDS

The National Bureau of Standards¹ was established by an act of Congress March 3, 1901. The Bureau's overall goal is to strengthen and advance the Nation's science and technology and facilitate their effective application for public benefit. To this end, the Bureau conducts research and provides: (1) a basis for the Nation's physical measurement system, (2) scientific and technological services for industry and government, (3) a technical basis for equity in trade, and (4) technical services to promote public safety. The Bureau consists of the Institute for Basic Standards, the Institute for Materials Research, the Institute for Applied Technology, the Institute for Computer Sciences and Technology, and the Office for Information Programs.

THE INSTITUTE FOR BASIC STANDARDS provides the central basis within the United States of a complete and consistent system of physical measurement; coordinates that system with measurement systems of other nations; and furnishes essential services leading to accurate and uniform physical measurements throughout the Nation's scientific community, industry, and commerce. The Institute consists of a Center for Radiation Research, an Office of Measurement Services and the following divisions:

Applied Mathematics — Electricity — Mechanics — Heat — Optical Physics — Nuclear Sciences² — Applied Radiation² — Quantum Electronics³ — Electromagnetics³ — Time and Frequency³ — Laboratory Astrophysics³ — Cryogenics³.

THE INSTITUTE FOR MATERIALS RESEARCH conducts materials research leading to improved methods of measurement, standards, and data on the properties of well-characterized materials needed by industry, commerce, educational institutions, and Government; provides advisory and research services to other Government agencies; and develops, produces, and distributes standard reference materials. The Institute consists of the Office of Standard Reference Materials and the following divisions:

Analytical Chemistry — Polymers — Metallurgy — Inorganic Materials — Reactor Radiation — Physical Chemistry.

THE INSTITUTE FOR APPLIED TECHNOLOGY provides technical services to promote the use of available technology and to facilitate technological innovation in industry and Government; cooperates with public and private organizations leading to the development of technological standards (including mandatory safety standards), codes and methods of test; and provides technical advice and services to Government agencies upon request. The Institute consists of a Center for Building Technology and the following divisions and offices:

Engineering and Product Standards — Weights and Measures — Invention and Innovation — Product Evaluation Technology — Electronic Technology — Technical Analysis — Measurement Engineering — Structures, Materials, and Life Safety⁴ — Building Environment⁴ — Technical Evaluation and Application⁴ — Fire Technology.

THE INSTITUTE FOR COMPUTER SCIENCES AND TECHNOLOGY conducts research and provides technical services designed to aid Government agencies in improving cost effectiveness in the conduct of their programs through the selection, acquisition, and effective utilization of automatic data processing equipment; and serves as the principal focus within the executive branch for the development of Federal standards for automatic data processing equipment, techniques, and computer languages. The Institute consists of the following divisions:

Computer Services — Systems and Software — Computer Systems Engineering — Information Technology.

THE OFFICE FOR INFORMATION PROGRAMS promotes optimum dissemination and accessibility of scientific information generated within NBS and other agencies of the Federal Government; promotes the development of the National Standard Reference Data System and a system of information analysis centers dealing with the broader aspects of the National Measurement System; provides appropriate services to ensure that the NBS staff has optimum accessibility to the scientific information of the world. The Office consists of the following organizational units:

Office of Standard Reference Data — Office of Information Activities — Office of Technical Publications — Library — Office of International Relations.

¹ Headquarters and Laboratories at Gaithersburg, Maryland, unless otherwise noted; mailing address Washington, D.C. 20234.

² Part of the Center for Radiation Research.

³ Located at Boulder, Colorado 80302.

⁴ Part of the Center for Building Technology.

A Review of Precision Oscillators

H. Hellwig

Time and Frequency Division
Institute for Basic Standards
National Bureau of Standards
Boulder, Colorado 80302

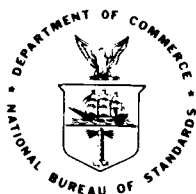

U.S. DEPARTMENT OF COMMERCE, Frederick B. Dent, Secretary

NATIONAL BUREAU OF STANDARDS Richard W. Roberts, Director

Issued February 1975

Library of Congress Catalog No. 75-600006
National Bureau of Standards Technical Note 662

Nat. Bur. Stand. (U.S.), Tech Note 662, 24 pages (Feb. 1975)

CODEN: NBTNAE

For sale by the Superintendent of Documents, U.S. Government Printing Office, Washington, D.C. 20402

(Order by SD Catalog No. C13.46:662) \$0.70

A REVIEW OF PRECISION OSCILLATORS

ABSTRACT

Precision oscillators used in PTTI applications include quartz crystal, rubidium gas cell, cesium beam, and hydrogen maser oscillators. A general characterization and comparison of these devices is given including accuracy, stability, environmental sensitivity, size, weight, power consumption, availability and cost. Areas of special concern in practical applications are identified and a projection of future performance specifications is given. An attempt is made to predict physical and performance characteristics of new designs potentially available in the near future.

Key Words: Accuracy; atomic clocks; clocks; crystal oscillator; frequency standards; stability; survey of clocks.

INTRODUCTION

Very recently, the author published a survey of atomic frequency standards [1,2]. This survey covered in an exhaustive way the presently available atomic standards, the manufacturers of these standards, as well as laboratories which are active in this field. The survey also included all known and published principles which are leading or may lead to new or improved frequency standards in the future. The reader is encouraged to study this and other recent surveys [3-8]. This paper does not duplicate these published results but rather expands them to include precision oscillators other than atomic oscillators and quantitative data on operational parameters such as warmup, retrace and several environmental effects. Also, this paper attempts to predict the performance of some new concepts which have been developed and which appear to pose no technical difficulties in their realization as frequency standards available in the near future. For these concepts stability, operational, and environmental parameters are predicted.

In this paper we will refrain from any discussion of new concepts or principles which, though promising, cannot yet be envisioned as being available in the near future. The following illustrates this important constraint: Saturated absorption stabilized lasers are omitted because their use as frequency standards or clocks is not possible at the present time because of the unavailability of a practical frequency synthesis chain in the infrared* which would allow the generation of precise standard frequencies and time signals from these standards which otherwise have documented competitive stability, and an interesting accuracy potential [10-13].

AVAILABLE STANDARDS

Figure 1 is adapted from Ref. 1 and 2. It includes crystal and superconducting cavity oscillators and various types of laboratory and commercial atomic frequency standards. Figure 1 shows that for short sampling times quartz crystal oscillators and superconducting cavity oscillators or rubidium masers are the oscillators of choice. For medium-term stability, the hydrogen maser and superconducting cavity oscillator are superior to any other standard which is available today. For very long-term stability or clock performance, cesium standards are presently the devices of choice. Rubidium standards are not superior in any region of averaging times, however, as shown in Table 1, they excel in the combination of good performance, cost and size.

It should be noted that in Fig. 1 the best available stabilities are listed for each class of standards regardless of other characterization of the devices. In contrast, Table 1 (and the following tables) combine stability data with operational data and other device characteristics. For each listed device in Table 1 the data may be viewed as being compatible, i.e., realizable in the very same device. Frequently, one finds in publications or other reference material that best performances are combined to create a super-device which is not actually available.

* The present realization is still too complex and lacks precision [9]; however, this important problem is being studied at various laboratories, and significant technical breakthroughs may be expected in the future.

Tables 1 and Fig. 1 illustrate that the choice of atomic frequency standards should be a matter of very careful consideration and weighing of the trade-offs and actual requirements. For any system application of precision oscillators, it is important to first determine the actually needed stability performance of the devices; secondly, to consider the environmental conditions under which the standard has to perform; and thirdly, the size, weight, cost and turn-on characteristics of the standard. Occasionally a system designer will find that a standard with all the characteristics needed does not exist yet on the market. In this case, the designer has two alternatives: either to adjust his system parameters to accommodate one of the available standards or to choose a combination of these standards to fulfill his need. The latter is an important aspect; for example, we assume that a system requires very good long-term stability and clock performance but at the same time high spectral purity, i.e., very good short-term stability. In addition, no cost, weight or size constraints are imposed. An optimum combination for this case could be a crystal oscillator paired with a cesium beam frequency standard. The systems concept as a solution to a design problem is a very powerful tool, and it can be realized technically at no sacrifice to the performance of the individual components of the system. The only actual restrictions may be physical size and cost. It should be noted here that many time scale generating systems are based on clock ensembles which feature not only several clocks of the same type but a combination of clocks of different design. For example, at the National Bureau of Standards we routinely use a combination of crystal oscillators and cesium standards when testing precision oscillators.

POTENTIALLY AVAILABLE STANDARDS

As was outlined in the Introduction, we list here only those devices and concepts which appear to be easily realizable within today's technology. A great many of highly promising and interesting concepts have been omitted at this time because they are too far removed from practical realizations or even practicality.

First, we assess existing standards (Table 1) and their future development capability (Table 2). In particular, we note that we expect stability improvements of about 1 order of magnitude in all four devices: crystal oscillators, hydrogen masers, cesium beam tubes, and rubidium standards.

In the case of crystals, this is due to better understanding and control of the noise behavior [14,15]. In the case of hydrogen, we expect an even better control of the cavity pulling effects which transduce temperature, pressure and vibrational effects into frequency fluctuations. A better understanding and control of the aging of rubidium cells due to improved control of the lamp intensity, as well as the gas composition in the cell appears possible. In cesium, an understanding of the flicker noise performance is expected as well as improved signal levels. Flicker noise effects may be due to cavity temperature gradients, microwave interrogation power fluctuations, magnetic field variations etc., all of which can be controlled to higher precision [1,2,16].

Table 3 lists five new concepts of devices. The cesium gas cell device is very much like the rubidium gas cell device except that cesium is used which necessitates a different lamp filter arrangement [17,18]. There is the potential that some aging effects may be better controllable with a cesium device because its different filter permits better control and higher symmetry of the optical spectrum. However, aside from this, the cesium gas cell device is expected to have characteristics similar to the projected performance of rubidium gas cell devices.

The dual-crystal concept is depicted in Fig. 2. The device consists of a crystal oscillator which is locked to a crystal resonator with a reasonably long time constant. The lock between the crystal oscillator and the passive crystal resonator can be envisioned as being rather simple using the dispersion lock technique studied in its basic feasibility with the hydrogen maser [19,20]. The advantage of a combination of a passive crystal with an active crystal oscillator lies in the realization of exceedingly high short-term stability in the oscillator, while the crystal resonator can be specifically designed for excellent long-term stability. In crystal oscillators short-term and long-term stability have been opposing goals, because high short-term stability typically requires rather high driving levels whereas excellent long-term stability requires low drive levels at the crystal resonator. A combination using two crystals could optimize on both in the same package.

The passive hydrogen device has been studied in detail and has demonstrated feasibility [19,20]. Its advantages rely to a high degree on the significant reduction of cavity pulling. As was mentioned already, cavity pulling serves as the transducer for temperature fluctuations, pressure fluctuations, mechanical stress fluctuations, etc., into frequency fluctuations. The passive device allows cavity Q's of 100 times or more below that of an oscillator and thus leads to a corresponding reduction in the cavity pulling effect. An increased environmental insensitivity coupled with a simplified design and excellent long-term stability without very high demands on the temperature stability can be realized. Figure 3 shows a block diagram of such a device. The hydrogen resonance is interrogated by a signal derived from a crystal oscillator. The signal is used to lock the crystal oscillator to the hydrogen resonance. In Fig. 3, dispersion locking is depicted which could simplify the overall system. A low cavity Q can be realized by using a lossy cavity but it appears advantageous to realize the low Q by using a very high cavity Q with a well defined mode, and lowering the Q electronically with negative feedback. This concept is shown in Fig. 3. In order to discriminate against long-term phase shifts in the electronics, an amplitude modulation of the hydrogen signal may be added. As shown in Fig. 3, this could be a hydrogen beam modulation.

Figure 4 shows the concept of a small and inexpensive atomic frequency standard. Traditionally, atomic frequency standards have been devised, designed, and built in order to achieve performances impossible to reach with crystal oscillators. In other words, the atomic resonance was used in the past to achieve excellence in performance. Thus, the selection of the atomic resonance as well as the whole design concept was directed towards achieving the utmost in stability and accuracy. A different design philosophy, however, appears possible. The weaknesses of a crystal oscillator are certainly not its size, weight, or power. They are the fact that crystals do not have a precise frequency without calibration, and that the crystal shows environmental sensitivity, in particular, with regard to temperature and acceleration (constant load, vibration, shock, etc.). If the atomic resonance is viewed only as a means to reduce or eliminate these negative performance characteristics of a crystal oscillator we are not necessarily constrained to resonances which lead to utmost stability and accuracy performance but others may be considered that lead to simpler designs. We therefore propose that a simple atomic standard could be built based on the well known

inversion transition in ammonia*. Ammonia will not permit the design of a standard exceeding significantly a 10^{-10} performance level in stability, accuracy, and environmental insensitivity, however, up to the 10^{-10} level a rather simple design concept should be realizable. Such an ammonia standard is depicted in Fig. 4 and its projected performance is depicted in Table 3. Again one could use the simple dispersion lock concept to control the frequency of the oscillator. The oscillator has not necessarily to be a crystal oscillator. If the standard is to operate under severe acceleration and vibration, the sensitivity of a crystal against these influences may cause loss of lock to the atomic resonance. Therefore, it may be advantageous to use other oscillator concepts such as a conventional LC or a Gunn effect oscillator. The device will have a performance which is in certain ways inferior to that of laboratory type crystal oscillators but it is projected that a combination of low cost, size and environmental insensitivity can be obtained which is not presently available with any other design solution.

Finally, in Fig. 5, we depict the superconducting cavity oscillator. This oscillator concept has been recently developed and studied, and it has demonstrated stability performance which exceeds that of any other known oscillator [23,24]. In fact, stabilities in the 10^{-16} region have been realized at averaging times of hundreds of seconds [25]. The superconducting cavity oscillator appears adaptable to commercial design and would be the best oscillator for medium-term stabilities (averaging times of 10 to 1000 s). It could therefore be of interest to users such as those engaged in very long baseline interferometry. It appears, however, unlikely that the superconducting cavity oscillator can become a very small and rugged device and it is equally unlikely that its environmental sensitivity can be reduced significantly from those values projected in Table 3.

* The ammonia molecule has served in the first "atomic clock" device [21] as well as in the ammonia maser [22] which opened up the modern field of quantum electronics. Ammonia was discarded for clock applications because 25 years ago it was technologically cumbersome to reach K-band and because ammonia is inferior with regard to the realization of superior accuracy and stabilities.

So far, we have only discussed stabilities for averaging times of 1 s or longer. Stabilities in the millisecond region correspond to very high spectral purity. This spectral purity is especially needed in the generation of frequencies in the infrared and visible radiation region from microwave sources. The two oscillators which play a crucial role in this regard are superconducting cavity oscillators and crystal oscillators. Studies of both of these devices have shown that significant improvement in the millisecond stability region should be possible which, in turn, should allow multiplication of these signals into the infrared region without the need for intermediate oscillators. Such oscillators (lasers) presently serve as spectral filters in the infrared synthesis work and speed of light measurements [9].

It has been projected that linewidths of less than about 100 Hz in the near infrared region should be possible without intermediate oscillators using either improved crystal oscillators or superconducting cavity oscillators, or using today's crystal oscillator paired with today's superconducting cavity as a filter at X-band [26]. Such linewidths would be totally adequate to do high precision metrology, since 100 Hz in the near infrared region represents parts in 10^{13} .

Thus the realization of a unified standard for length of time [27,28] and a control of frequencies in the infrared and visible region is crucially tied to the availability of new oscillators.

Acknowledgments

The author is indebted to the many individuals, laboratories and companies who provided information which made possible the compiling of data of Tables 1 and 2 and Fig. 1. D. W. Allan and F. L. Walls contributed important information in many discussions. S. R. Stein provided data on the superconducting cavity oscillator; Fig. 5 is adapted from his thesis [25].

Tables 1-3

The listed data are average values for the respective types of standards taken from publications, reports and manufacturers specifications. There may be significant deviations towards better or worse data for certain models under certain operating conditions. The listed data for one type have generally been realized in at least one existing device. Therefore, some stability data are not as good as those of Fig. 1 which refer to the best achieved values (regardless of operational, physical, or environmental characteristics). The following is an explanation of the terms used in the second half of the Tables (the terms in the first part of the Tables are self-explanatory): Warmup is the time required to reach a frequency within 10^{-9} of the "final" frequency (i.e., after several days). In atomic standards it is practically equivalent to the time required for reaching a locked condition. Retrace is the ability of the device to reproduce - after a complete turn-off (long enough to return to shelf storage temperature) - the frequency before the power interruption. Temperature and acceleration sensitivities are self-explanatory, however, it must be noted that crystals are inherently sensitive to these effects due to the fact that the crystal resonator itself changes frequency under these environmental loads, whereas atoms are inherently unaffected. However, the proper design of temperature control can reduce these effects significantly. Acceleration refers quantitatively to constant g-loads; however, the values indicate qualitatively the related sensitivities to vibration and shock. Barometric effects are transduced into frequency variations via design features, and thus are reducible by improved design. Magnetic effects are acting directly on the atoms changing their frequency, but - as in the case of temperature for crystals - this effect can be reduced almost arbitrarily by shielding (though affecting cost and size) for all atomic standards.

REFERENCES

- [1] Hellwig, H., "Atomic frequency standards: a survey," Proc. 28th Annual Symp. on Freq. Contr., pp. 315-339, May 1974.
- [2] Hellwig, H., "Atomic frequency standards: a survey," Proc. IEEE, vol. 63, pp. 212-229, Feb. 1975.
- [3] McCoubrey, A. O., "A survey of atomic frequency standards," Proc. IEEE, vol. 54, pp. 116-135, Feb. 1966.
- [4] Kartaschoff, P., and Barnes, J.A., "Standard time and frequency generation," Proc. IEEE, vol. 60, pp. 493-501, May 1972.
- [5] Audoin, C., "Revue des oscillateurs atomiques et moléculaires," L'Onde Electrique, vol. 53, pp. 39-45, Feb. 1973.
- [6] Hellwig, H., "Areas of promise for the development of future primary frequency standards," Metrologia, vol. 6, pp. 118-126, Oct. 1970.
- [7] Beehler, R. E., "A historical review of atomic frequency standards," Proc. IEEE, vol. 55, pp. 792-805, June 1967.
- [8] Ramsey, N. F., "History of atomic and molecular frequency control of frequency and time," Proc. 25th Annual Symp. on Freq. Contr., pp. 46-51, Apr. 1971.
- [9] Evenson, K. M., Wells, J. S., Petersen, F. R., Danielson, B. L., Day, G. W., Barger, R. L., and Hall, J. L., "Speed of light from direct frequency and wavelength measurements of the methane-stabilized laser," Phys. Rev. Lett., vol. 29, No. 19, pp. 1346-1349, Nov. 1972.
- [10] Hall, J. L., and Borde, C., "Measurement of methane hyperfine structure using laser saturated absorption," Phys. Rev. Lett., vol. 30, pp. 1101-1104, May 1973.
- [11] Barger, R. L. and Hall, J. L., "Wavelength of the 3.39 μ m laser-saturated absorption line of methane," Appl. Phys. Lett., vol. 22, pp. 196-199, Feb. 1973.

- [12] Hellwig, H., Bell, H. E., Kartaschoff, P., and Bergquist, J. C., "Frequency stability of methane-stabilized He-Ne lasers," J. Appl. Phys., vol. 43, pp. 450-452, Feb. 1972.
- [13] Brillet, A., Cerez, P., and Clergeot, H., "Frequency stabilization of He-Ne lasers by saturated absorption," IEEE Trans. Quant. Electron, vol. QE-10, pp. 526-527, June 1974.
- [14] Wainwright, A. E., Walls, F. L., and McCaa, W. D., "Direct measurements of the inherent frequency stability of quartz crystal resonators," Proc. 28th Annual Symp. on Freq. Contr., pp. 177-180, May 1974.
- [15] Walls, F. L., and Wainwright, A. E., "Measurement of the short-term stability of quartz crystal resonators and the implications for crystal oscillator design and applications," IEEE Trans. on Instrum. & Meas., vol. IM-24, March 1975 (to be published).
- [16] Howe, D. A., Bell, H. E., Hellwig, H., and DeMarchi, A., "Preliminary research and development of the cesium tube accuracy evaluation system," Proc. 28th Annual Symp. on Freq. Contr., pp. 362-372, May 1974.
- [17] Beverini, N., and Strumia, F., "High efficiency hyperfine filter for the cesium resonance lines," Optics Commun., vol. IM-23, Dec. 1974, to be published.
- [18] Leschiutta, S., and Strumia, F., "Optically pumped cesium cell frequency standard," Conf. on Prec. Electromag. Meas., Conference Digest, London, July 1974.
- [19] Hellwig, H., and Bell, H., "Experimental results with atomic hydrogen storage beam systems," Proc. 26th Annual Symp. on Freq. Contr., pp. 242-247, June 1972.
- [20] Hellwig, H., and Bell, H., "Some experimental results with an atomic hydrogen storage beam frequency standard," Metrologia, vol. 8, pp. 96-98, Apr. 1972.
- [21] Lyons, H., "The Atomic Clock," NBS Technical News Bulletin, vol. 33, No. 2, pp. 17-24, Feb. 1949.
- [22] Shimoda, K., Wang, T. C., and Townes, C. H., "Further aspects of the theory of the maser," Phys. Rev., vol. 102, pp. 1308-1321, June 1956.

- [23] Stein, S. R., and Turneaure, J. P., "The development of superconducting cavity stabilized oscillators," Proc. 27th Annual Symp. on Freq. Contr., pp. 414-420, 1973.
- [24] Jimenez, J. J., and Septier, A., "S & X-band superconducting cavity stabilized oscillators," Proc. 27th Annual Symp. on Freq. Contr., pp. 406-413, 1973.
- [25] Stein, S. R., "The superconducting cavity stabilized oscillator and an experiment to detect time variation of the fundamental constants," High Energy Physics Lab., Stanford University, HEPL Report 741, Oct. 1974.
- [26] Walls, F. L., and DeMarchi, A., "RF spectrum of a signal after frequency multiplication; measurements and comparison with a simplified calculation," to be published.
- [27] Hellwig, H., and Halford D., "Accurate frequency measurements: Survey, significance, and forecast," NBS Special Publication 343, pp. 17-26, Aug. 1971.
- [28] IAU Resolution, Sydney, Australia, 1973.

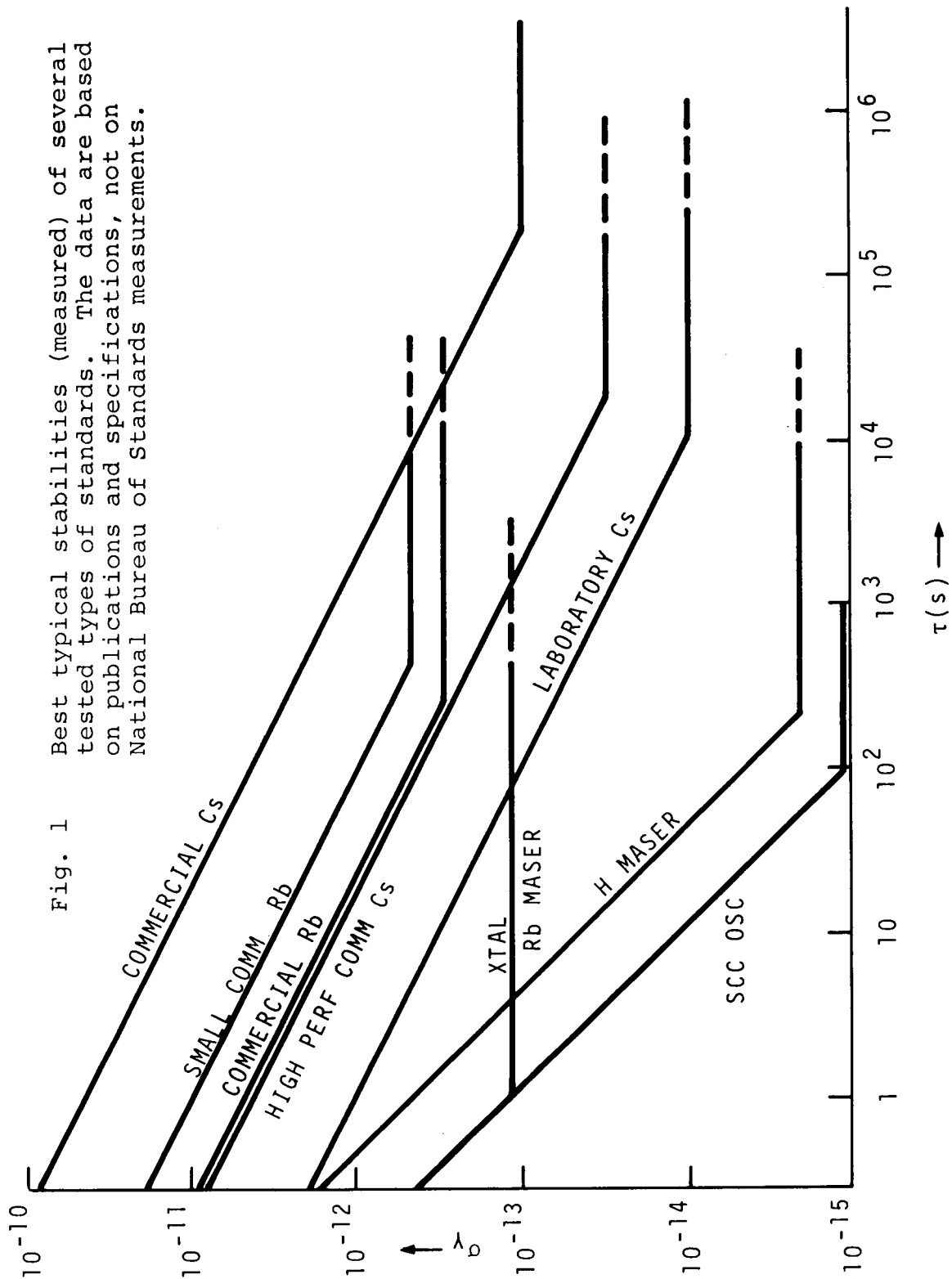

Fig. 1 Best typical stabilities (measured) of several tested types of standards. The data are based on publications and specifications, not on National Bureau of Standards measurements.

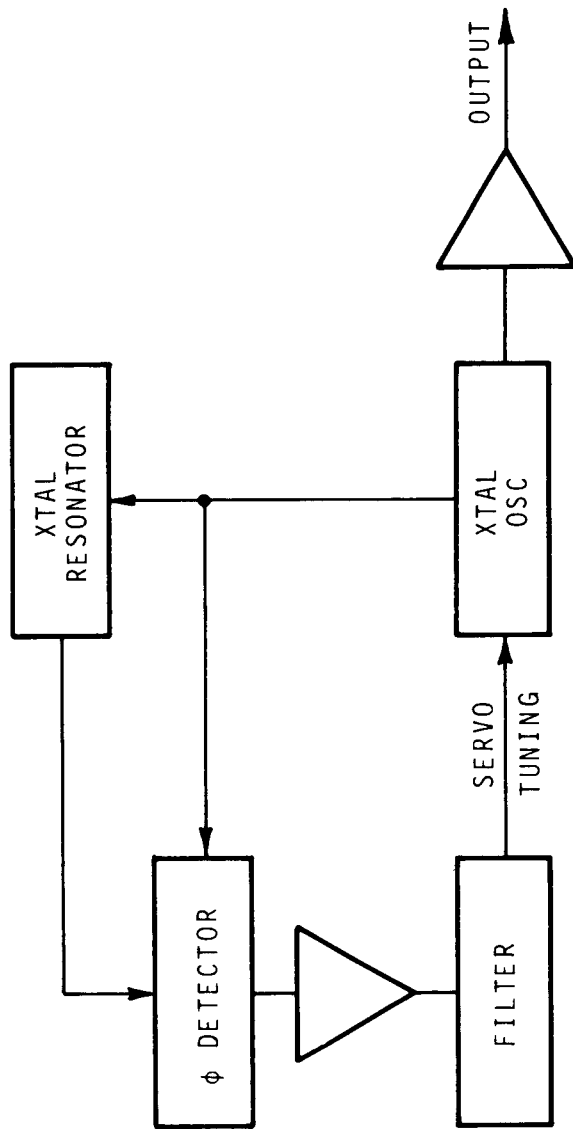

FIG. 2 Dual crystal concept. The crystal oscillator (high level drive) is servoed to a passive crystal resonator (low drive level) using the phase sensitive dispersion lock technique.

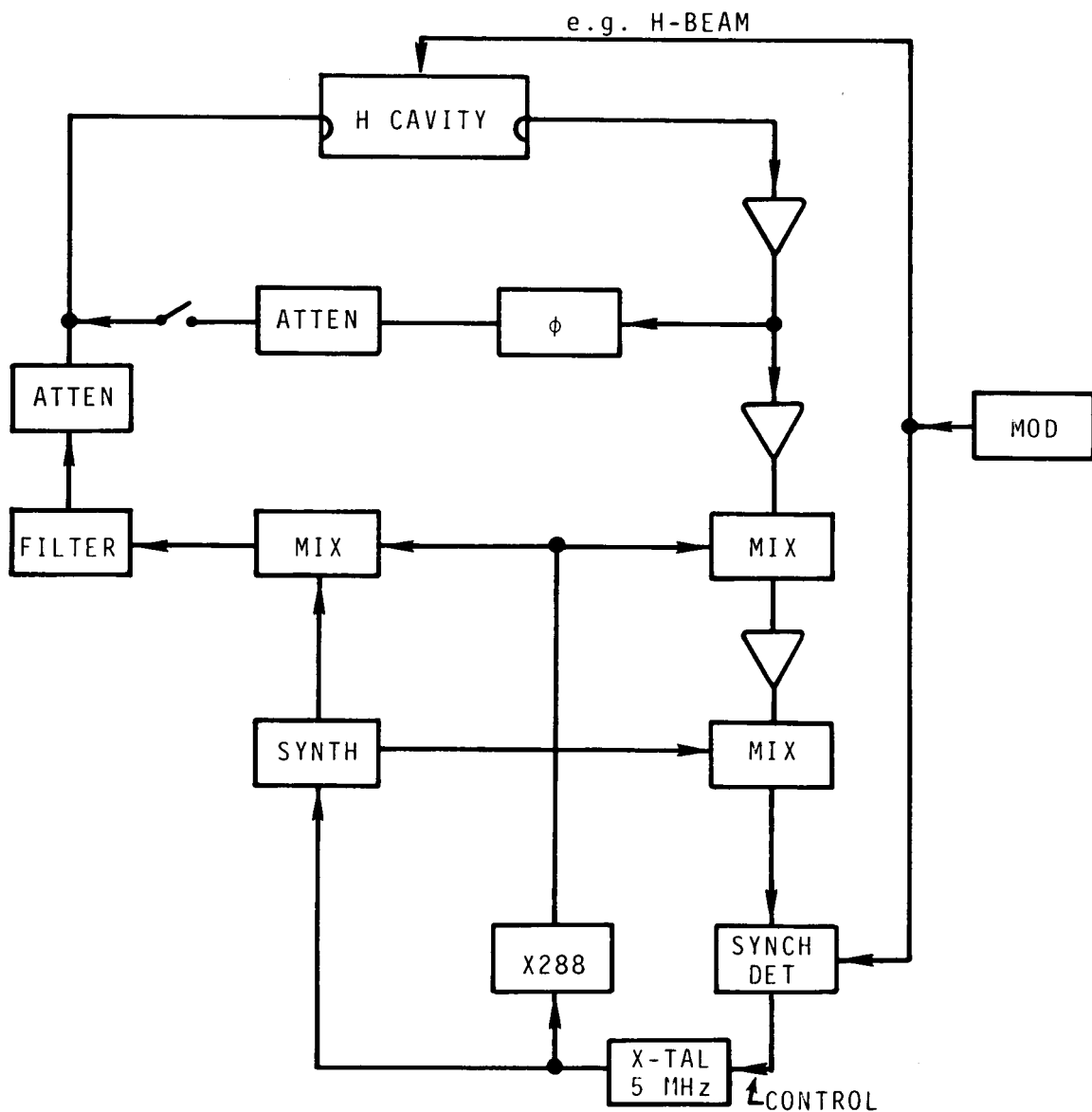

FIG. 3 Passive hydrogen concept. The crystal oscillator is locked to the hydrogen resonance using the phase sensitive dispersion lock technique. The cavity-Q is lowered using negative electronic feedback.

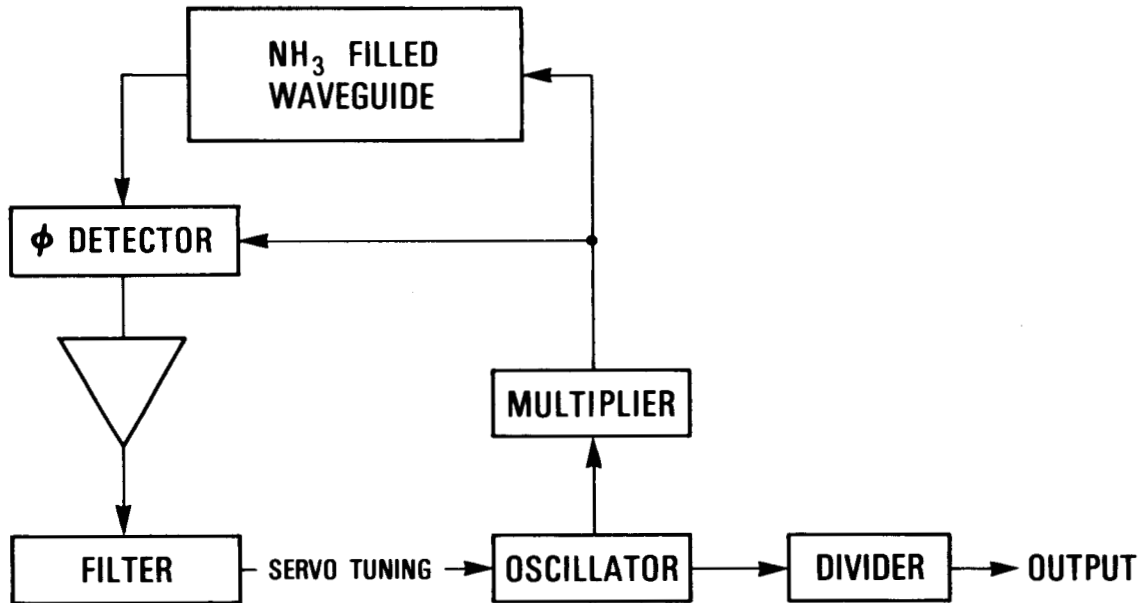

FIG. 4 Utility standard concept. The oscillator is locked to a resonance in ammonia (K-band) using the phase sensitive dispersion lock technique. The oscillator may not necessarily be a crystal oscillator but a Gunn effect oscillator or other conventional source.

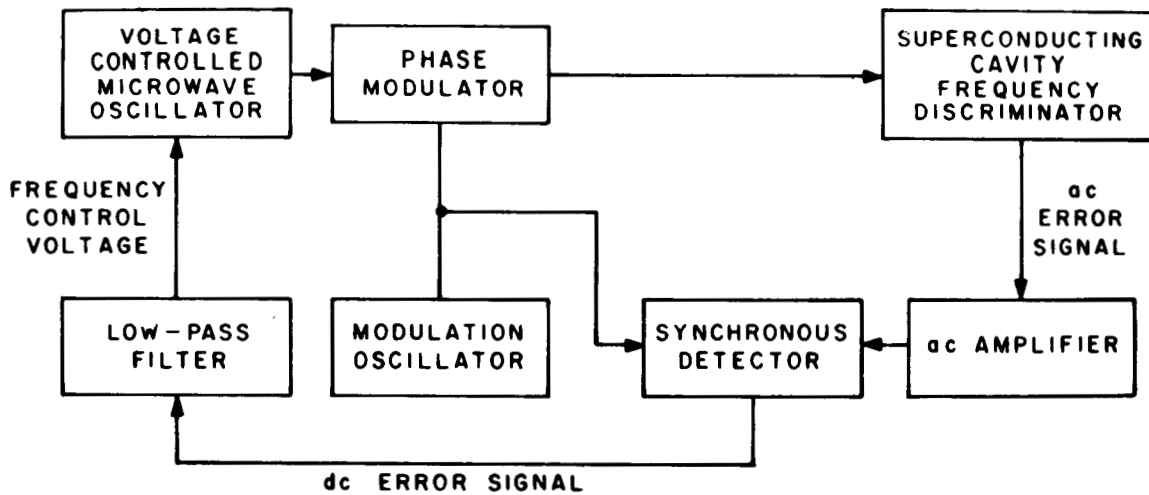

FIG. 5 Superconducting cavity oscillator. A Gunn effect oscillator is servoed to a superconducting cavity using conventional lock loop techniques [23,24].

AVAILABLE TODAY

	COST (K\$)	SIZE (ℓ)	WEIGHT (lb)	POWER (W)	STABILITY		
					1s	FLOOR	DRIFT (per day)
X-tal	0.7 - 3	1	1	3	10^{-11}	10^{-11}	10^{-10}
Rb(gas cell)	3.5 - 8	1	2	15	10^{-11}	10^{-12}	10^{-12}
Cs (tube)	15	20	40	30	10^{-11}	10^{-13}	10^{-14}
H (maser)	100	100	90	20	10^{-12}	10^{-14}	10^{-14}

	WARM-UP		ENVIRONMENT			
	TIME for 10^{-9}	RETRACE	TEMP (per °C)	ACCL. (per g)	BAROM. (per mbar)	MAG. FIELD (per G)
X-tal	1h	10^{-10}	10^{-11}	10^{-9}	-	-
Rb (gas cell)	10 min.	10^{-11}	10^{-11}	10^{-12} (est.)	10^{-12}	10^{-12}
Cs (tube)	30 min.	10^{-12}	10^{-13}	10^{-13}	10^{-14}	10^{-12}
H (maser)	1 min.	10^{-12}	10^{-13}	10^{-12} (est.)	10^{-14}	10^{-12}

TABLE 1 Available devices.

POTENTIALLY AVAILABLE

	COST (K\$)	SIZE (l)	WEIGHT (lb)	POWER (W)	STABILITY		
					1s	FLOOR	DRIFT (per day)
X-tal	0.7 - 3	0.5	0.5	2	10^{-11}	10^{-12}	10^{-10}
Rb (gas cell)	2	1	2	10	10^{-12}	10^{-13}	10^{-13}
Cs (tube)	10	10	20	20	10^{-12}	10^{-14}	10^{-15}
H (maser)	80	100	90	20	10^{-12}	10^{-15}	10^{-15}

	WARM-UP		ENVIRONMENT			
	TIME (for 10^{-9})	RETRACE	TEMP (per °C)	ACCL (per g)	BAROM (per mbar)	Mag Field (per G)
X-tal	1 hr.	10^{-10}	10^{-11}	10^{-9}	- -	- -
Rb (gas cell)	10 min	10^{-12}	10^{-12}	10^{-13}	10^{-13}	10^{-12}
Cs (tube)	15 min	10^{-12}	10^{-13}	10^{-13}	10^{-14}	10^{-12}
H (maser)	1 min	10^{-12}	10^{-13}	10^{-12}	10^{-14}	10^{-12}

TABLE 2 Potential of presently available devices for the near future.

POTENTIALLY AVAILABLE

	COST (K\$)	SIZE (l)	WEIGHT (lb)	POWER (W)	STABILITY		
					1s	FLOOR	DRIFT (per day)
Dual X-tal	1 - 3	1	1	2	10^{-13}	10^{-13}	10^{-11}
Cs (gas cell)	4 - 8	2	3	10	10^{-12}	10^{-13}	10^{-13}
H (passive)	50	60	70	15	10^{-12}	10^{-15}	10^{-16}
Utility atomic standard	1 - 2	1	2	2	10^{-12}	10^{-11}	10^{-12}
SCC-Osc.	20	100	100	100	10^{-13}	10^{-15}	10^{-13}

TABLE 3a Potential of new design concepts judged realizable in the near future.

POTENTIALLY AVAILABLE

	WARM-UP		ENVIRONMENT			
	TIME (for 10^{-9})	RETRACE	TEMP (per °C)	ACCL. (per g)	BAROM. (per mbar)	MAG. FIELD (per G)
Dual X-tal	10 min	10^{-11}	10^{-11}	10^{-7}	- -	- -
Cs (gas cell)	10 min	10^{-12}	10^{-12}	10^{-13}	10^{-13}	10^{-12}
H (passive)	1 min	10^{-13}	10^{-15}	10^{-14}	10^{-15}	10^{-12}
Utility atomic standard	1s	10^{-10}	10^{-12}	10^{-14}	10^{-15}	10^{-13}
SCC-Osc	3h	10^{-12} *	(10^{-11})	10^{-7}	(10^{-14})	- - - -

* assuming that the device stays at superconducting temperatures, otherwise 10^{-7}

TABLE 3b Potential of new design concepts judged realizable in the near future.

NBS TECHNICAL PUBLICATIONS

PERIODICALS

JOURNAL OF RESEARCH reports National Bureau of Standards research and development in physics, mathematics, and chemistry. It is published in two sections, available separately:

• Physics and Chemistry (Section A)

Papers of interest primarily to scientists working in these fields. This section covers a broad range of physical and chemical research, with major emphasis on standards of physical measurement, fundamental constants, and properties of matter. Issued six times a year. Annual subscription: Domestic, \$17.00; Foreign, \$21.25.

• Mathematical Sciences (Section B)

Studies and compilations designed mainly for the mathematician and theoretical physicist. Topics in mathematical statistics, theory of experiment design, numerical analysis, theoretical physics and chemistry, logical design and programming of computers and computer systems. Short numerical tables. Issued quarterly. Annual subscription: Domestic, \$9.00; Foreign, \$11.25.

DIMENSIONS/NBS (formerly **Technical News Bulletin**)—This monthly magazine is published to inform scientists, engineers, businessmen, industry, teachers, students, and consumers of the latest advances in science and technology, with primary emphasis on the work at NBS. The magazine highlights and reviews such issues as energy research, fire protection, building technology, metric conversion, pollution abatement, health and safety, and consumer product performance. In addition, it reports the results of Bureau programs in measurement standards and techniques, properties of matter and materials, engineering standards and services, instrumentation, and automatic data processing.

Annual subscription: Domestic, \$9.45; Foreign, \$11.85.

NONPERIODICALS

Monographs—Major contributions to the technical literature on various subjects related to the Bureau's scientific and technical activities.

Handbooks—Recommended codes of engineering and industrial practice (including safety codes) developed in cooperation with interested industries, professional organizations, and regulatory bodies.

Special Publications—Include proceedings of conferences sponsored by NBS, NBS annual reports, and other special publications appropriate to this grouping such as wall charts, pocket cards, and bibliographies.

Applied Mathematics Series—Mathematical tables, manuals, and studies of special interest to physicists, engineers, chemists, biologists, mathematicians, computer programmers, and others engaged in scientific and technical work.

National Standard Reference Data Series—Provides quantitative data on the physical and chemical properties of materials, compiled from the world's literature and critically evaluated. Developed under a world-wide

program coordinated by NBS. Program under authority of National Standard Data Act (Public Law 90-396).

NOTE: At present the principal publication outlet for these data is the **Journal of Physical and Chemical Reference Data (JPCRD)** published quarterly for NBS by the American Chemical Society (ACS) and the American Institute of Physics (AIP). Subscriptions, reprints, and supplements available from ACS, 1155 Sixteenth St. N. W., Wash. D. C. 20056.

Building Science Series—Disseminates technical information developed at the Bureau on building materials, components, systems, and whole structures. The series presents research results, test methods, and performance criteria related to the structural and environmental functions and the durability and safety characteristics of building elements and systems.

Technical Notes—Studies or reports which are complete in themselves but restrictive in their treatment of a subject. Analogous to monographs but not so comprehensive in scope or definitive in treatment of the subject area. Often serve as a vehicle for final reports of work performed at NBS under the sponsorship of other government agencies.

Voluntary Product Standards—Developed under procedures published by the Department of Commerce in Part 10, Title 15, of the Code of Federal Regulations. The purpose of the standards is to establish nationally recognized requirements for products, and to provide all concerned interests with a basis for common understanding of the characteristics of the products. NBS administers this program as a supplement to the activities of the private sector standardizing organizations.

Federal Information Processing Standards Publications (FIPS PUBS)—Publications in this series collectively constitute the Federal Information Processing Standards Register. Register serves as the official source of information in the Federal Government regarding standards issued by NBS pursuant to the Federal Property and Administrative Services Act of 1949 as amended, Public Law 89-306 (79 Stat. 1127), and as implemented by Executive Order 11717 (38 FR 12315, dated May 11, 1973) and Part 6 of Title 15 CFR (Code of Federal Regulations).

Consumer Information Series—Practical information, based on NBS research and experience, covering areas of interest to the consumer. Easily understandable language and illustrations provide useful background knowledge for shopping in today's technological marketplace.

NBS Interagency Reports (NBSIR)—A special series of interim or final reports on work performed by NBS for outside sponsors (both government and non-government). In general, initial distribution is handled by the sponsor; public distribution is by the National Technical Information Service (Springfield, Va. 22161) in paper copy or microfiche form.

Order NBS publications (except NBSIR's and Bibliographic Subscription Services) from: Superintendent of Documents, Government Printing Office, Washington, D.C. 20402.

BIBLIOGRAPHIC SUBSCRIPTION SERVICES

The following current-awareness and literature-survey bibliographies are issued periodically by the Bureau: **Cryogenic Data Center Current Awareness Service**

A literature survey issued weekly. Annual subscription: Domestic, \$20.00; foreign, \$25.00.

Liquefied Natural Gas. A literature survey issued quarterly. Annual subscription: \$20.00.

Superconducting Devices and Materials. A literature

survey issued quarterly. Annual subscription: \$20.00. Send subscription orders and remittances for the preceding bibliographic services to National Technical Information Service, Springfield, Va. 22161.

Electromagnetic Metrology Current Awareness Service Issued monthly. Annual subscription: \$100.00 (Special rates for multi-subscriptions). Send subscription order and remittance to Electromagnetics Division, National Bureau of Standards, Boulder, Colo. 80302.