

Satellite scintillation observations at Boulder, Colorado

J. L. JESPERSEN and GEORGE KAMAS
Central Radio Propagation Laboratory
National Bureau of Standards
Boulder, Colorado

(Received 12 November 1963)

Abstract—Observations of radio signals from an artificial earth satellite were used in a study of F -region irregularities. In general, the average height of the irregularities was found to change with magnetic latitude. Occasionally the height changes discontinuously with magnetic latitude and it is shown how this effect can be related to a thickening of the layer in the ionosphere containing the irregularities.

A difference in the geographical distribution of the irregularities as observed at Boulder, Colorado and Urbana, Illinois appears to be related to a change in the latitudinal distribution of spread- F from sunspot maximum to minimum. The spectrum of irregularity size is found to consist of one or more discrete components and in general the spectra are similar for observations at two different radio frequencies.

1. INTRODUCTION

OBSERVATIONS of radio signals at 54 and 150 Mc/s from an artificial earth satellite were used in a study of F -region irregularities. The main results of these observations in their order of presentation are: (a) the height and shape of the region containing the irregularities; (b) the geographical distribution of the regions containing the irregularities; (c) the effect of the elevation angle of the satellite upon the observations; (d) the correlation of the irregular fading signal at the two frequencies; and (e) the spectrum of sizes of the irregularities.

2. EQUIPMENT

The antenna system (see Fig. 1) consisted of three pairs of Yagi antennas arranged in the form of an equilateral triangle. Prior to each pass, the antennas were pointed in the direction of "closest approach" of the satellite. Low noise, "Cascode" preamplifiers, located at the base of each antenna, were used to drive the long coaxial transmission lines to the central receiving facility. The preamplifier-antenna combinations were adjusted for equal gain and the over-all noise figure was measured to be about 3.5 dB for each of the several units. The received signals at 54 Mc/s and 150 Mc/s were converted, in crystal controlled preamplifiers to an intermediate frequency of 30 Mc/s. A signal transmitted from the central control building just prior to the satellite pass was used to check the antenna system and to provide a calibration check.

The receivers (see Fig. 1) were calibrated just before each pass with the calibrations recorded on the magnetic tape recorder so as to become a permanent part of the record. Since the receiver bandwidth was only 3 kc/s the satellite signal was frequency-tracked during the pass to remove the Doppler shift. The receivers were operated with fixed gain and the record carefully examined against the

calibrations to ensure that no overload occurred. An auxiliary detector was employed and its direct-current component was nulled so that the tape recorder input oscillator would not be shifted from its linear range.

A FM tape recorder was used to record all the the signals simultaneously in time synchronism. The recorder output was played back onto paper chart recorders simultaneously to permit monitoring of the recorded signals. One channel of the tape was used to record a time-code signal so that a time resolution of 1 sec was possible.

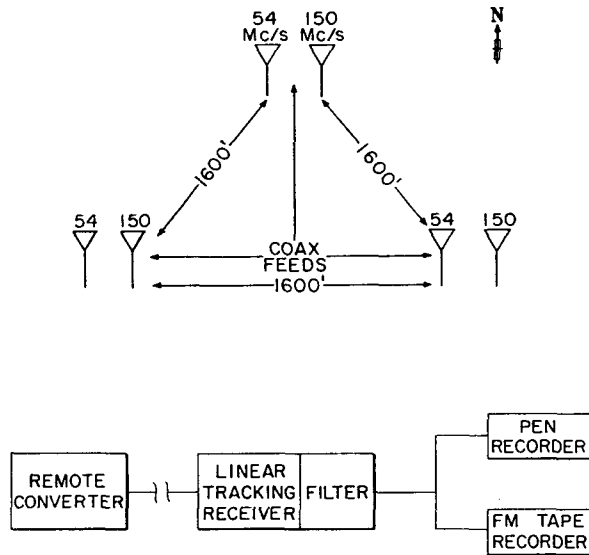

Fig. 1. Antenna configuration and receiver channel block diagram.

During data reduction, the tape playback speed was reduced and the signals were accurately filtered to remove all frequencies above the maximum frequency resolvable by the paper-tape recording system. By the combination of tape speed reduction and time multiplexing (see Fig. 2) three of the original magnetic tape channels could be punched onto paper tape for computer processing. The paper-tape data were plotted and compared with a chart recording of the tape recorder output to insure that there were no errors on the paper tape.

3. OBSERVATIONS

In the absence of ionospheric irregularities the amplitude of a satellite signal fades smoothly as a function of time due to Faraday rotation (LITTLE and LAWRENCE, 1960). When irregularities are present there is, in addition to the smooth fading, a faster irregular component as shown in Fig. 3. SLEE (1958) has shown that the irregularities discussed here are the same or similar to those which are responsible for radio star scintillations, so that we will refer to the irregular fading on satellite records as scintillations.

Since it is known that scintillations are most likely to occur at night (LAWRENCE *et al.*, 1961) two-thirds of the 102 observations were made during the interval between 2 hr after sunset and 2 hr before sunrise. We will refer to these observations as the nighttime observations. Of the nighttime records, about 60 per cent show scintillations. About half of the total number of observations were taken simultaneously at three stations (Fig. 1) and the others at one station only.

4. HEIGHT AND SHAPE OF THE REGION CONTAINING THE IRREGULARITIES

FRIHAGEN and TROIM (1960) have shown that the velocity, V , of the irregular fading pattern across the ground is given by

$$V = - \frac{h}{H - h} U \quad (1)$$

where H is the height of the satellite, h the height of the irregularities, and U the

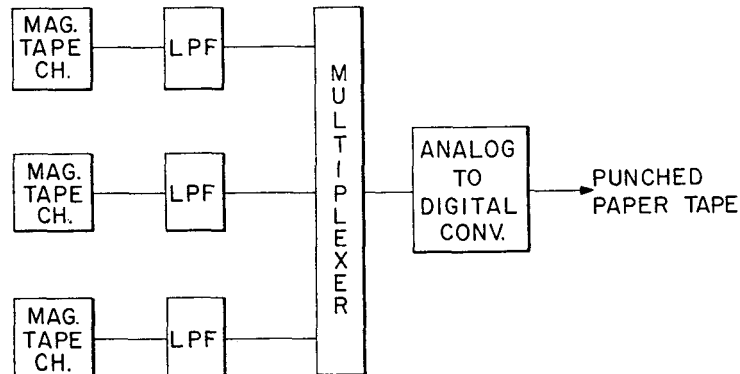

Fig. 2. Data processing.

horizontal component of the satellite velocity. V may be found by measuring the time displacement, t , of similar fades observed at two stations of known spacing, placed parallel to the direction of motion (say α) of the pattern across the ground. To compute t , we have used a full correlation analysis rather than the method of similar fades (BRIGGS *et al.*, 1950; PHILLIPS and SPENCER, 1955).

In general α will not remain constant during a satellite pass so that, with two stations one may measure V only for a limited portion of the observation. However, with the addition of a third station, as in Fig. 1, V is measurable for the entire observation because now the orientation of the pattern across the ground can be found, and this information, along with t , is sufficient to calculate V (BRIGGS *et al.*, 1950; PHILLIPS and SPENCER, 1955). This extension in the measurement of V is of considerable advantage because it permits h to be determined over a wide range of geographic positions from a single satellite pass.

Since equation (1) is valid only for plane-earth geometry, it will not be applicable to observations made at low elevation angles. To extend the measurement of h over the widest possible range of elevation angles we produced a table which gives, as a function of position of the satellite for a particular pass, V for assumed

values of h up to the height of the satellite. Then, given V and the position of the satellite, h may be found from the table.

Figures 4 and 5 show the result of applying these methods to a number of short sections of record taken from two different nighttime passes. Here h is plotted as a function of geomagnetic latitude since scintillations are known to be under geomagnetic rather than geographic control (SPENCER, 1955). To determine the error in the measurement of h , we divided several of the short records in half and computed h for each of the two halves. In general these values of h differed by less than 4 km.

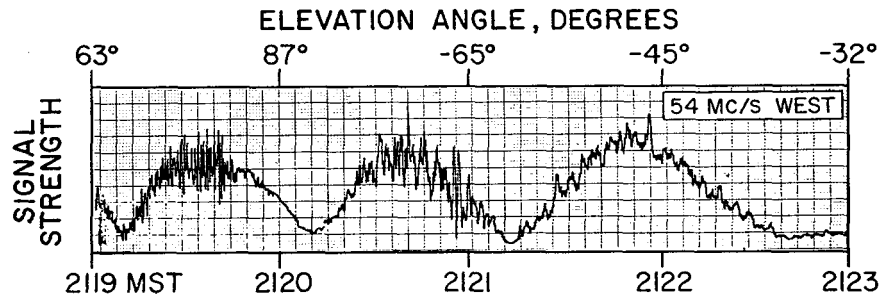

Fig. 3. Amplitude variations at 54 Mc/s.

Figures 4 and 5 are typical of the results from most of the records in that within the experimental error there is no difference in h at 54 and 150 Mc/s. Since theory and experiment show that the amplitude of the scintillations will be smaller at the higher frequency (BOOKER, 1958) it is not always possible to obtain simultaneous values of h at both frequencies. Figure 4 shows h to be fairly uniform over a distance of several hundred km (1° lat. ~ 100 km) whereas Fig. 5 shows a discontinuity. About two-thirds of the observations are similar to Fig. 4 and the rest to Fig. 5.

Figure 6 shows a straight line fitted by least squares to values of h obtained from 10 nighttime observations which showed no discontinuity and for which 3 or more values of h were available for each pass. The most noticeable feature is the gradual increase (about 13 km per 100 km) in the average height of the irregularities with increasing geomagnetic latitude. A similar plot as a function of longitude shows no systematic effect.

Figure 7 shows diagrammatically how the observations typified by Fig. 5 might arise. The numbered positions along the satellite path correspond respectively to the numbered observations in Fig. 5. The dark areas in Fig. 7 indicate regions containing irregularities. It is possible that the whole region enclosed by the broken line contains irregularities and that the dark regions indicate where the irregularities in electron density are most intense so that these regions are primarily responsible for the pattern on the ground.

Observations of this type show that there is sometimes a considerable variation in the thickness, T , of the region responsible for the scintillations. For observations near the zenith, the line of sight from observer to the satellite will pass simultaneously through all regions containing irregularities so that the deduced height

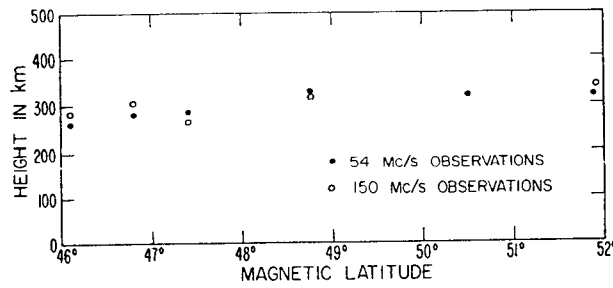

Fig. 4. Height of the irregularities as a function of magnetic latitude.

Fig. 5. Example of an observation showing a non-uniform variation in the height of the irregularities as a function of magnetic latitude.

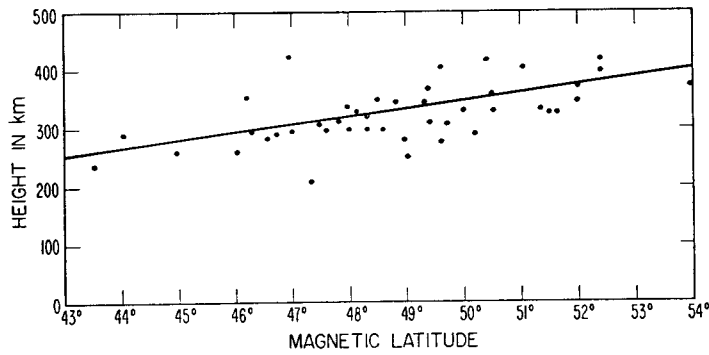
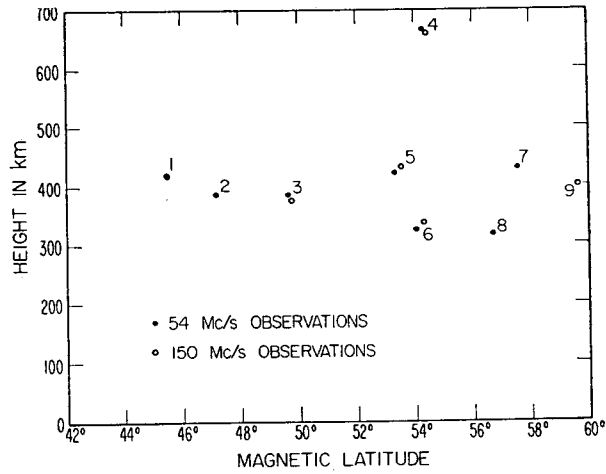
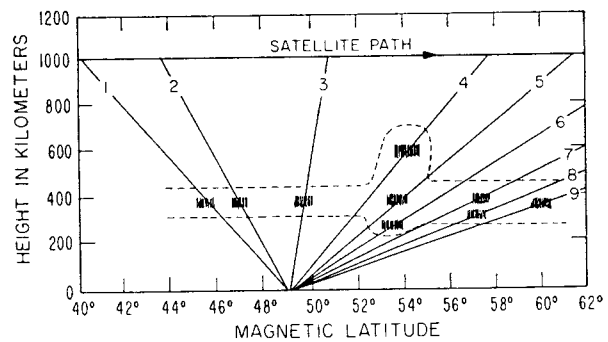

Fig. 6. Height of the irregularities as a function of magnetic latitude for ten nighttime observations at 54 Mc/s.

Fig. 7. Diagrammatic representation of irregularities responsible for observations in Fig. 6.



will depend upon the distribution of the irregularities overhead. Therefore, observations near the zenith will not give any indication of T except insofar as the average height may be related to T . A different approach to the measurement of T , which is applicable to both high and low elevation angles, has been considered theoretically by JAMES (1962). The principle of this method is based upon the following idea. V depends upon h as shown in equation (1). If the irregularities are at several different heights, the fading pattern on the ground will be the resultant of several patterns moving with different velocities, and therefore the pattern will change as it moves along the ground at a rate which depends upon T . If one assumes that the irregularities are uniformly distributed over T , and if the r.m.s phase deviations, ϕ , introduced into the signal by the irregularities do not exceed 1 rad, then James shows that

$$T = \frac{4V_c UH}{(U + V)^2} \quad (2)$$

where V_c has the dimensions of velocity and is the ratio of a typical irregularity size along the direction of motion of the pattern to the mean lifetime of the irregularity. V_c was introduced by BRIGGS *et al.* (1950) in connection with ionospheric fading studies and it may be computed using the correlation method described by them.

With the best available records the experimental error in the measurement of V_c is about 10 per cent of V which, from equation (2), gives a minimum T of about 80 km. We have applied this method to 8 of these best 54 Mc/s records: 6 values of T were obtained from 6 different records giving a height variation of the type shown in Fig. 4, and 7 values were obtained from two records giving a height variation of the type shown in Fig. 5. For the former type T ranged between 120 and 300 km with an average of 184 km. The number of cases is, however, too small to establish any geographical dependence. For the latter type, T ranged between 90 and 470 km with the largest values of T associated with the highest values of h . Figure 8 shows this for one of these records; the magnetic latitude at Boulder is about 49°N so that the transition between the thick and thin regions occurred near the observer's zenith in contrast to the case illustrated in Fig. 5, where the increase is to the north of Boulder. As we would expect, for a thickening near the zenith, there is an abrupt increase in h , since the line of sight penetrates simultaneously all regions in the layer containing irregularities. When the thickening occurs away from the zenith, there is a fluctuation in the value of h near the discontinuity, as in Fig. 5, because different parts of the thickened regions are observed sequentially.

Observations of the type depicted in Figs. 5 and 8 indicate that changes in h are associated with variations in T , suggesting that the increase in the average height of the irregularities as shown in Fig. 6 is due to a gradual thickening to the north of the layer containing irregularities. The irregularities may extend to both higher and lower regions of the ionosphere toward the north, but if the rate of increase of the height of the top of the layer is greater than the rate of decrease in height of the bottom of the layer then the average height will increase toward the north. This asymmetrical increase in T is apparent in Fig. 8 and in Fig. 7 which is

based on the results shown in Fig. 5. In addition, other observations made at high latitudes support the conclusion. BASLER and DE WITT (1962) report on the basis of satellite observations at College, Alaska (geomag. lat. 64.5° N) that h lies between 145 and 1000 km with the majority of the values uniformly distributed between 250 and 650 km with an average height of 450 km, as compared to Boulder, where the majority of the values are between 250 km and 400 km with an average height of 325 km. BASLER and DE WITT also suggest that in some cases their values of h are measures of either the upper or lower boundary of the layer indicating again that the layer has considerable vertical extent.

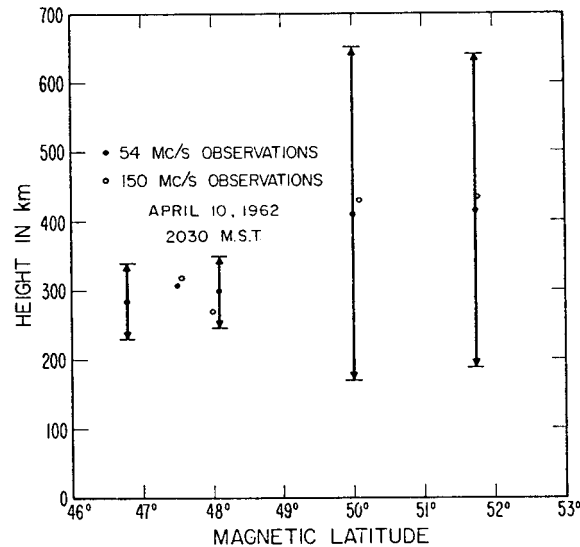

Fig. 8. Example of an observation showing the variation of the height and thickness, T , of the irregularities with magnetic latitude. T is indicated by the length of the arrow.

JAMES (1962) has shown that h may be obtained directly from V only when the irregularities are confined to a thin layer. However, the error in the measurement of h will be important only for very thick layers. For example, in Fig. 8 the values of h are about 3 per cent too high in the thin layer region and about 15 per cent too high in the thick layer region, and in this latter case the values of h were corrected before plotting. This effect would produce an apparent increase in h to the north even if T increased symmetrically; however, one can show that to explain the variation of h shown in Fig. 6 in this way, T would have to increase so rapidly that the layer would soon extend from the ground to the satellite.

5. GEOGRAPHICAL DISTRIBUTION OF THE REGIONS CONTAINING THE IRREGULARITIES

Several workers in the northern hemisphere (YEH and SWENSON, 1959; KENT, 1959) have reported that, in general, scintillations appear to the north and not to the south of their observing station and that the transition between the two regions is very abrupt. At Boulder we observed a sharp transition in about 17 per cent of

the records, but there did not appear to be any particular geographic position at which these transitions occurred. Other workers in the northern hemisphere (BAIN, 1960; FRIHAGEN and TROIM, 1961) have reported scintillations both to the north and south of their point of observation. At Boulder we observed scintillations to the north and south about 70 per cent of the time, which is particularly interesting when compared with YEH and SWENSON'S (1959) observations at Urbana, Illinois since Boulder and Urbana are at about the same geomagnetic latitude (geomag. lat. 49°N).

Scintillations and spread- F are known to be correlated and it is interesting to compare these scintillation observations with spread- F observations. SHIMAZAKI (1959) has published data showing the magnetic latitudinal variation in the probability of occurrence of spread- F at sunspot maximum and minimum. Figure 9 reproduces these results along with the approximate time of the Urbana and Boulder observations in the sunspot cycle. From the figure we see that spread- F occurred primarily at latitudes greater than 49°N during sunspot maximum but was about equally distributed about 49°N during sunspot minimum so that the difference in the Urbana and Boulder scintillation observations is not surprising. However, from the figure, we would expect workers at much higher and lower latitudes to see scintillations to the north and south at any time in the sunspot cycle.

For the rest of the observations the scintillation irregularities were contained in patches ranging from a few kilometers up to several hundred kilometers along the direction of motion of the satellite. Other workers (YEH and SWENSON, 1959; AARONS *et al.*, 1961; SINGLETON and LYNCH, 1962) have reported patches from 100 to 600 km in size on the basis of satellite observations, and radio star scintillation observations (LAWRENCE *et al.*, 1961) indicate patches of this order. However, patches a few kilometers in size do not seem to have been reported previously, and we will consider this point again in Section 9 in connection with other observations.

6. ELEVATION-ANGLE DEPENDENCE OF THE SCINTILLATION OBSERVATIONS

Other workers (BAIN, 1961; FRIHAGEN and TROIM, 1961) in the northern hemisphere report that the intensity of scintillations increases toward the north. Figure 10 shows this effect as observed at Boulder. The scintillation index, $(\Delta A/A)^2$, (BOOKER, 1958) has been plotted as a function of elevation angle. For any particular elevation angle, the scintillation index may have values scattered over the entire range of the ordinate scale, however the curve shown in the figure was produced by averaging over values of $(\Delta A/A)^2$ obtained from observations to the magnetic north (magnetic azimuth angles between 0° and 90° and between 270° and 0°) and south of Boulder. (The number of observations near the zenith is small so that this region has been filled in with the dashed line.) A similar plot of $(\Delta A/A)^2$ to the magnetic east and west of Boulder shows no asymmetry.

Several points should be considered with respect to this figure. The main shape of the curve is due to the fact that as the elevation angle decreases the length of the propagation path through the ionosphere increases (BOOKER, 1958).

LITTLE *et al.* (1962) and YEH (1962) have shown theoretically that because the irregularities are aligned along the earth's magnetic field $(\Delta A/A)^2$ will be enhanced

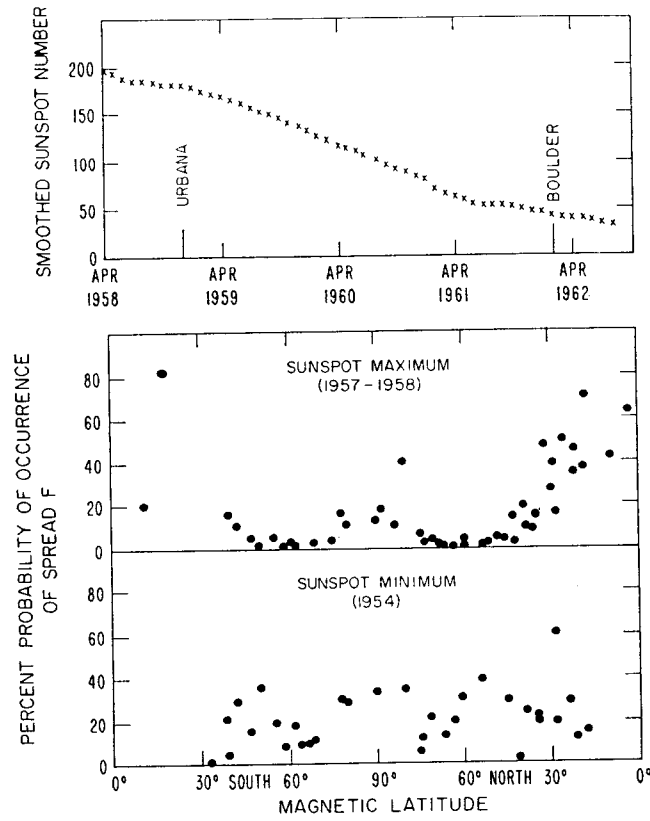

Fig. 9. Relation between the latitudinal distribution of spread- F^7 at sunspot maximum and minimum and the time of observation of scintillations at Boulder and Urbana.

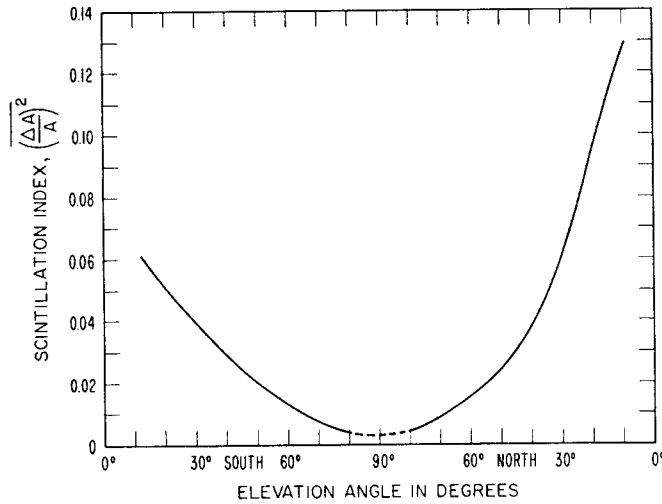

Fig. 10. Variation of the scintillations as a function of elevation angle to the north and south of Boulder. The figure was obtained by drawing a smooth line through the average value of the scintillation index as a function of elevation angle.

for observations along the field lines. This condition occurs to the south of Boulder at an elevation angle of about 68° . No effect of this kind is evident in the figure but it must be recognized that any variation would be minimized in the figure since $\overline{(\Delta A/A)^2}$ was obtained by averaging over different azimuth angles. In any event, even if the effect were present, the scintillations are clearly more intense to the north.

LITTLE (1951) has shown that the amplitude of the scintillations is proportional to the phase change introduced in the first Fresnel zone. Therefore, if the satellite is a distance z_1 from the irregularities and the irregularities a distance z_2 from the observer, $\overline{(\Delta A/A)^2}$ will be proportional to $[Z_1 Z_2 / (Z_1 + Z_2)]^2 = \beta$.

If the average height of the irregularities varies, as in Fig. 6, β will have a non-symmetrical effect on the variation of $\overline{(\Delta A/A)^2}$ at elevation angles to the north and south. β is a maximum when $z_1 = z_2$ which implies that irregularities at a height of about 470 km will be most effective in producing scintillations because the average height of the satellite was about 940 km. Therefore, from Fig. 6, $\overline{(\Delta A/A)^2}$ will continue to increase toward the north over the range of observation from Boulder. This effect, however, is insufficient to explain the north-south asymmetry in Fig. 10. For example at an elevation angle of 25° the ratio, r , of $\overline{(\Delta A/A)^2}$ to the north and south of Boulder, from Fig. 10, is about 1.7; whereas, the effect of height variation alone would produce a ratio of about 1.2.

Theory (BOOKER, 1958) shows that $\overline{(\Delta A/A)^2}$ is proportional to T and to $\overline{(\Delta N)^2}$, the mean square departure of electron density from the mean, so that the increase in $\overline{(\Delta A/A)^2}$ could be due to an increase of T or of $\overline{(\Delta N)^2}$ to the north, or to a combination of these two factors. In Section 4 there is evidence that T increases to the north. If we assume that $\overline{(\Delta N)^2}$ remains constant and that to the first order the height of the bottom of the layer remains constant as a function of latitude, then it is possible to find T using the information given in Figs. 6 and 10. Thus, if one finds r from Fig. 10 for some elevation angle, it is easily shown that the thickness, T , of the layer to the south in the region of the ionosphere intersected by the line of sight from the observer to the satellite at that elevation angle is given by

$$T_s = \frac{2(h_n - h_s)}{(r - 1)} \quad (3)$$

and the thickness to the north, T_n by

$$T_n = r T_s \quad (4)$$

where h_n and h_s are the average heights of the layer to the north and to the south. To stay away from the region where the signal is propagated along field lines, we will find T for an elevation angle of 25° . In this case as before $r = 1.7$, $h_n = 390$ km and $h_s = 270$ which, from equations (3) and (4), gives $T_n = 580$ km and $T_s = 340$ km. These values of T appear to be too large on the basis of the observations discussed in Section 4 and in addition, these values put the bottom of the layer at 100 km which is contrary to radio star scintillation observations at Boulder

(LAWRENCE *et al.*, 1961) which indicated that there was no relation between scintillations and *E*-region phenomena. CHIVERS and DAVIES (1962), on the basis of radio star scintillation observations, report irregularities in the *E*-region; and more recently HOOK and OWREN (1962) report *E*-region irregularities on the basis of spaced-station satellite measurements. However, these observations refer to high latitudes, and it is suggested by the authors that the observations are related to auroral phenomena. [WILD and ROBERTS (1956) found a relation between a type of radio star scintillation (ridge scintillations) and *E*-region irregularities somewhat larger than those usually responsible for scintillations. We will discuss this point again in Section 7.] We conclude that $(\Delta N)^2$ increases to the north so that T will not have to increase at an unreasonable rate to explain the observations.

7. CORRELATION BETWEEN THE SCINTILLATIONS AT TWO FREQUENCIES

Various workers have measured the cross-correlation between radio star scintillations at different frequencies (BOLTON and STANLEY, 1948; SMITH, 1950; BURROWS and LITTLE, 1952). CHIVERS (1960) has concluded on the basis of these observations and his own that the correlation coefficient will be insignificant if the frequency ratio of the observations is 3:1 or greater. Unpublished radio star scintillation observations at Boulder at frequencies of 53 and 108 Mc/s have shown an insignificant cross-correlation of about 0.1. However, these observations were made at low elevation angles so that the lack of correlation may in part be due to different ray paths at the two frequencies caused by refraction in the ionosphere.

For the satellite observations, with a frequency ratio of 3:1, the cross-correlation ranged between 0.2 and 0.3 for observations at high elevation angles, which is in general agreement with CHIVER's conclusion. However, on one occasion during a daytime pass, a cross-correlation of 0.6 was observed, but in this case, the fading rate was considerably slower than usual and indicated an irregularity size of about 10 km along the direction of motion of the satellite. The spaced-station measurements indicated a height of about 140 km which was lower than any of the other observations. These observations are probably related to the "ridge scintillations" mentioned in Section 6. Wild and ROBERTS suggest that the ridge scintillations are due to irregularities which are large enough to act like individual lenses so that the pattern on the ground is highly correlated over frequencies ranging from 40 to 70 Mc/s. Also, the irregularities were found by WILD and ROBERTS to be associated with *E*-region phenomena, which substantiates the height measurement obtained from our observation.

In addition to WILD and ROBERTS, LISZKA (1962) at Kiruna, Sweden and WARWICK (1963) at Boulder have reported observations of ridge scintillations. WARWICK's observations are of particular interest since they, as well as the observations described here, were made at Boulder. As stated in the previous paragraph, radio star scintillation observations at 53 and 108 Mc/s and satellite observations at 54 and 150 Mc/s showed little or no correlation (except for the cases noted) in apparent disagreement with WARWICK's results. However, part of the disagreement may be related to the fact that WARWICK's observations were made over a lower frequency range (7.6–41 Mc/s) than those described here.

8. SPECTRUM OF THE IRREGULARITY SIZES

Radio star (JONES, 1960) and satellite (FRIHAGEN and TROIM, 1960) scintillation observations show that the irregularity size transverse to the earth's magnetic field is of the order of 1 km and of the order of 2 or more km along the field line depending upon the latitude of the observation. Most irregularity sizes have been obtained either by estimating the fading rate of the scintillation record by eye or by finding the time shift for which the auto-correlation coefficient of a record falls to some predetermined value and then converting these measurements to an irregularity size on the basis of information about the velocity of the fading pattern along the ground. Either of these methods will indicate only some average irregularity size which depends upon the actual distribution of sizes.

Most theoretical discussions have assumed that the spectrum of irregularities is rectangular. Recently, however, WAGNER (1962) considered other types of spectra and shows that different spectra will produce important differences in subsequent results.

Satellites present a good opportunity to study the spectrum of irregularities since the ionosphere may be considered frozen during the time required for an observation. To obtain the spectrum, we computed power spectra (the power per unit bandwidth in the scintillation record) using the Tukey method (TUKEY, 1949) for 70 different short records taken from 18 passes. The shape of the spectra fall into two classes about equally divided between the two types shown in Figs. 11 and 12, where the ordinate scale is arbitrary so that only relative values of power in the spectra are meaningful. In general, the spectra are of one type or the other for a particular pass.

In order to test the stationarity of the spectra, we divided ten records in half and computed power spectra for each of the two halves. For these cases, there was no significant difference between the two halves and the original record indicating that the spectra were stationary.

Various workers (MAXWELL, 1954; BOOKER, 1956; DAGG, 1957) have considered the importance of turbulence in the production of *F*-region irregularities. JONES (1960) has given experimental evidence that turbulence does not play an important part in the production of scintillation irregularities, and this conclusion is supported by the power spectra shown here since one would expect any turbulence-controlled spectra to vary smoothly with irregularity size.

Methods generally used to find irregularity size will be adequate for records with spectra of the type shown in Fig. 11 but not for Fig. 12, and in neither case are the spectra similar to those considered in theoretical discussions.

The frequency scales at the top of Figs. 11 and 12 were converted to irregularity size for the lower scales in each figure. The size shown is transverse to the earth's magnetic field and was obtained on the basis of information concerning the position of the satellite, the orientation of the pattern on the ground, and the velocity of the pattern. The irregularity size shown in figure 11 is in agreement with previous results, but Fig. 12 shows that there may be more than one component present.

Several additional points should be considered in connection with these spectra.

(i) The lack of power at the low frequency end of the spectra does not necessarily indicate that there are no irregularities corresponding to these frequencies.

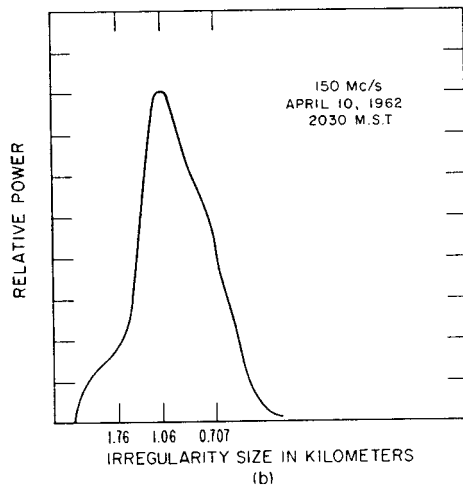
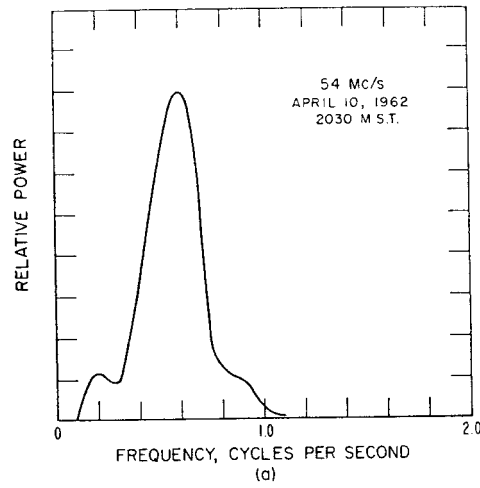

Fig. 11. Spectra showing one irregularity size.

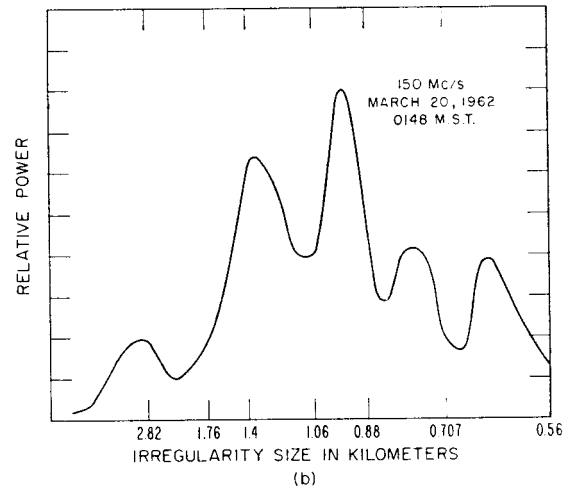
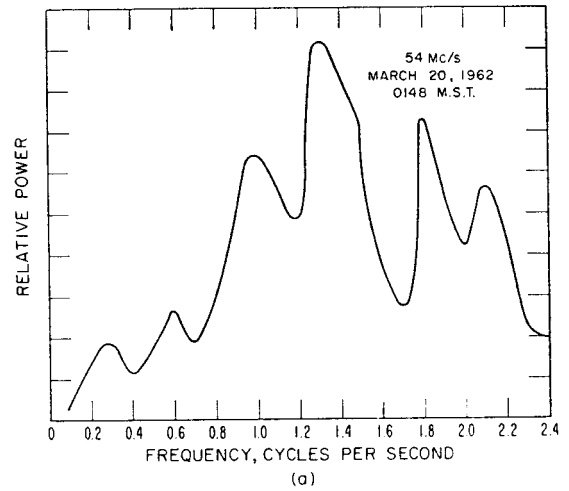

Fig. 12. Spectra showing more than one irregularity size.

HEWISH (1951) showed that the observer must be in the Fraunhofer region of the diffraction pattern for the amplitude effects to have fully developed. For satellite observations at a radio wave length λ , this implies that

$$l < \sqrt{\frac{Z_1 Z_2 \lambda}{Z_1 + Z_2}} \quad (5)$$

if the amplitude effects associated with an irregularity of size l are to be fully developed.

For the observations described here, the value of l which just meets condition (5) is of the order of 1 km so that the low frequency end of the spectra will tend to be excluded. To estimate the importance of this effect, theory shows (BOOKER, 1958) that when condition (5) is not satisfied, the mean square amplitude scintillations are proportional to l^{-4} . Therefore a two to one increase in l would result in a factor of 16 decrease in the observed power.

The highest frequency which can appear in the power spectrum of a record is given by half the rate at which the record is sampled. For these power spectra the upper limit is about 30 c/s which is at least a factor of 10 higher than the cut-off frequencies shown in Figs. 11 and 12, and this indicates that the diminution toward high frequency end of the spectrum is real.

(ii) If the r.m.s. phase deviation, ϕ , introduced by the ionosphere exceed 1 rad, then the scale of the diffraction pattern on the ground will be l/ϕ (HEWISH, 1951), and the power spectrum would not indicate directly the size of the irregularities in the ionosphere. However, in this case one would not expect the spectra to be similar at the two frequencies, as they are in Fig. 12, since ϕ is proportional to λ . In addition to this, theory shows (BOOKER, 1958) that when the scintillations are small $(\Delta A/A)^2 = \overline{\phi^2}$. For the 150 Mc/s observation $(\Delta A/A)^2 \approx 0.05$ giving $\phi \approx 0.22 < 1$ rad which is sufficiently small for the 150 Mc/s power spectrum to indicate directly the ionospheric irregularity size.

(3) Figure 6 shows that at times the layer producing the scintillation is quite thick with a non-uniform distribution of irregularities in the layer. Therefore, if irregularities are at two or more distinct heights, they will produce fading patterns moving with different velocities across the ground which would produce spikes in the power spectrum. This indicates that one might expect to see a transition from a single to a multiple spiked spectrum when there is a transition from a thin to a thick region. Power spectra were computed for records showing these transitions, but there is no clear indication of any correspondence of this type.

GRUBER (1961) computed power spectra from radio star scintillation records and also obtained spikes. He suggests that the spikes are related to ridge scintillations. However, this is not the case for the Boulder observations since it was shown in Section 7 that the cross-correlation between the scintillations at the two frequencies (except for the one case) is quite small.

In general, the fading rate is similar at both frequencies as in Figs. 11 and 12. Occasionally, however, there is a difference in fading rate with the higher fading rate usually associated with the lower radio frequency. These cases occur when the scintillations are quite intense, indicating that ϕ exceeds one radian at the lower frequency. However, in several instances the fading rate is slower at the

lower frequency apparently indicating an irregularity size of about 3 km at 54 Mc/s and about 1 km at 150 Mc/s. These observations occur at low elevation angles when the patch containing the irregularities is of the order of 10 km in size.

MERCIER (1961) and BRIGGS (1961) show that the scale size of the pattern on the ground is given by l if

$$\theta \geq \theta_s \quad (6)$$

and by λ/θ if

$$\theta_s \geq \theta \quad (7)$$

where l is the irregularity size in the ionosphere, θ the angle subtended at the observer by a patch of size L a distance R away, and $\theta_s = \lambda/l$ is the scattering angle associated with an irregularity size l . In most instances scintillation observations will meet condition (6).

For the present observations at an elevation angle of about 10° , $R \approx 1400$ km, $L \approx 10$ km so that $\theta \approx 0.014$. If we assume $l \approx 1$ km then $\theta_s \approx 0.006$ at 54 Mc/s and ≈ 0.002 at 150 Mc/s. Therefore the observations described here fall in between conditions (6) and (7). If condition (7) were clearly met, the fading rate would indicate an irregularity size of about 4 km at 54 Mc/s and about 1.5 km at 150 Mc/s. The observed results are about what one would expect since the observation at 54 Mc/s more closely meets condition (7) than does the observation at 150 Mc/s.

9. CONCLUSIONS

Observations concerning the height of irregularities responsible for scintillations fall into two categories. In the majority of the cases the average height increases toward the north at a rate of about 13 km per 100 km along the ground, with the average height at Boulder being about 325 km. For the rest of the observations the height jumps discontinuously between its average value and some higher value. Two different types of observations show that the discontinuous increase in height is due to a thickening of the layer containing the irregularities and evidence is given that the smooth height increase is related to the same effect.

Observations at Urbana, Illinois showed that, in general, irregularities were not present in regions to the south of Urbana while more recent observations at about the same geomagnetic latitude at Boulder disclosed irregularities both to the north and south. We have shown that the difference between these observations appears to be related to the change in the latitudinal distribution of spread- F from sunspot maximum and minimum.

In agreement with other workers, the intensity of scintillations is found to increase toward the north. Evidence is given that this increase in intensity is due jointly to an increase in the thickness of the layer containing the irregularities and to an increase in the electron density variations in the layer.

The cross-correlation coefficient between scintillations separated by a 3:1 frequency ratio is found to range between 0.2 and 0.3 in general agreement with previous results. On one occasion, however, the correlation was about 0.6 and it is suggested that this result is related to ridge-scintillations occurring at E -region heights.

It is shown that the spectrum of irregularity size transverse to the earth's

magnetic field is made up of one or more discrete components and that on no occasion is there a continuous distribution of irregularity size.

In general, the observations at two different radio frequencies indicate the same irregularity size. On occasion, however, the irregularity size indicated by the lower frequency is either smaller or larger than the size indicated by the higher frequency, and it is shown that these observations can be related to the intensity of the scintillations or to the size of the patch containing the irregularities respectively.

Acknowledgements—The authors are indebted to Mr. Robert S. Lawrence for valuable comments and suggestions. This project was supported by the Ballistic Missiles Division of the United States Air Force under Contract No. AFO4(647)134

REFERENCES

- | | | |
|---|------|---|
| AARONS, J., WHITNEY, H. E., ROGER, R. S., THOMSON, J., BOURNAZEL, J., VASSEY, E., HESS, H. A., RAWER, K., CARRARA, N., CHECCACCI, P., LANDMARK, B., TROIM, J., HULTQVIST, B. and LISZKA, L. | 1961 | <i>Planet. Space Sci.</i> 5 , 169. |
| BAIN W. C. | 1961 | <i>Nature, Lond.</i> 189 , 129. |
| BASLER R. P. and DEWITT R. N. | 1962 | <i>J. Geophys. Res.</i> 67 , 587. |
| BOLTON J. G. and STANLEY G. J. | 1948 | <i>Aust. J. Sci. Res.</i> A1 , 58. |
| BOOKER H. G. | 1956 | <i>J. Geophys. Res.</i> 61 , 673. |
| BOOKER H. G. | 1958 | <i>Proc. I.R.E.</i> 46 , 298. |
| BRIGGS B. H. | 1961 | <i>Proc. Phys. Soc. Lond.</i> 77 , 305. |
| BRIGGS H. G., PHILLIPS G. J. and SHINN D. H. | 1950 | <i>Proc. Phys. Soc. Lond.</i> B63 , 106. |
| BURROWS K., and LITTLE C. G. | 1952 | <i>Jodrell Bank Annuals</i> 1 , 29. |
| CHIVERS H. J. A. | 1960 | <i>J. Atmosph. Terr. Phys.</i> 17 , 181. |
| CHIVERS H. J. A. and DAVIES R. D. | 1962 | <i>J. Atmosph. Terr. Phys.</i> 24 , 573. |
| DAGG M. | 1957 | <i>J. Atmosph. Terr. Phys.</i> 11 , 139. |
| FRIHAGEN J. and TROIM J. | 1960 | <i>J. Atmosph. Terr. Phys.</i> 18 , 75. |
| FRIHAGEN J. and TROIM J. | 1961 | <i>J. Atmosph. Terr. Phys.</i> 20 , 215. |
| GRUBER S. | 1961 | <i>J. Atmosph. Terr. Phys.</i> 20 , 59. |
| HEWISH A. | 1951 | <i>Proc. Roy. Soc.</i> A209 , 81. |
| HOOK L. J. and OWREN LEIF | 1962 | <i>J. Geophys. Res.</i> 67 , 5353. |
| JAMES P. W. A. | 1962 | <i>J. Atmosph. Terr. Phys.</i> 24 , 237. |
| JONES I. L. | 1960 | <i>J. Atmosph. Terr. Phys.</i> 19 , 26. |
| KENT G. S. | 1959 | <i>J. Atmosph. Terr. Phys.</i> 16 , 10. |
| LAWRENCE R. S., JESPERSEN J. L. and LAMB R. C. | 1961 | <i>J. Res. Nat. Bur. Stds.</i> 65D , 333. |
| LISZKA L. | 1962 | Kiruna Geophys. Obs. Scientific Rep. No. 4. |
| LITTLE C. G. | 1951 | <i>Mon. Not. R. Astr. Soc.</i> 111 , 289. |
| LITTLE C. G. and LAWRENCE R. S. | 1960 | <i>J. Res. Nat. Bur. Stds.</i> 64D , 335. |
| LITTLE C. G., REID G. C., STILTNER E. and MERRITT R. P. | 1962 | <i>J. Geophys. Res.</i> 67 , 1763. |
| MAXWELL A. | 1954 | <i>Phil. Mag.</i> 45 , 1247. |
| MERCIER R. P. | 1961 | <i>Proc. Phys. Soc. Lond.</i> 77 , 318. |
| PHILLIPS G. J. and SPENCER M. | 1955 | <i>Proc. Phys. Soc. Lond.</i> 68B , 481. |
| SHIMAZAKI T. | 1959 | <i>J. Radio. Res. Labs. (Tokyo)</i> 6 , 669. |
| SINGLETON D. G. and LYNCH G. J. E. | 1962 | <i>J. Atmosph. Terr. Phys.</i> 24 , 363. |

- SLEE O. B. 1958 *Nature, Lond.* **181**, 1610.
SMITH F. G. 1950 *Nature, Lond.* **165**, 423.
SPENCER M. 1955 *Proc. Phys. Soc. Lond.* **B68**, 493.
TUKEY J. 1949 Symposium on *Applications of Auto-correlation Analysis to Physical Problems*. Woods Hole, Mass. Office of Naval Res., Wash. D.C.
- WAGNER L. S. 1962 *J. Geophys. Res.* **67**, 4187.
WARWICK J. W. 1963 *Astr. J., Yale* **68**, 81.
WILD J. P. and ROBERTS J. A. 1956 *J. Atmosph. Terr. Phys.* **8**, 55.
YEH K. C. and SWENSON G. W. 1959 *J. Geophys. Res.* **64**, 2281.
YEH K. C. 1962 *J. Res. Nat. Bur. Stds.* **66D**, 621.