

# A TWSTFT calibration guideline and the use of a GPS calibrator for UTC TWSTFT link calibrations

Z. Jiang<sup>1</sup>, D. Matsakis<sup>2</sup>, V. Zhang<sup>3</sup>, H. Esteban<sup>4</sup>, D. Piester<sup>5</sup>, S.Y. Lin<sup>6</sup>, E. Dierikx<sup>7</sup>

1 BIPM: Bureau International des Poids et Mesures, Sevres, France, [zjiang@bipm.org](mailto:zjiang@bipm.org)

2 USNO: United States Naval Observatory, 3450 Massachusetts Ave, NW, Washington DC 20392, US,

3 NIST: National Institute of Standards and Technology, 325 Broadway, Boulder, CO80305, US

4 ROA: Real Instituto y Observatorio de la Armada en San Fernando, Spain

5 PTB: Physikalisch-Technische Bundesanstalt, Bundesallee 100, 38116 Braunschweig, Germany

6 TL: National Standard Time and Frequency Laboratory, Telecommunication Laboratories, Chungghwa Telecom, Taiwan

7 VSL: VSL, Dutch Metrology Institute, Delft, The Netherlands

## BIOGRAPHIES

Dr. Zhiheng JIANG obtained his PhD at Paris Observatory. He worked at the Research Institute of Surveying and Mapping, Beijing China; the French Geographical Institute, France and since 1998 at the International Bureau of Weights and of Measures (BIPM) as a principal physicist. His main interest is in timing metrology and gravimetry, and he is deeply involved in the generation of the international time scale, Coordinated Universal Time (UTC). Email: [zjiang@bipm.org](mailto:zjiang@bipm.org) ;

Dr. Demetrios Matsakis is Chief Scientist for Time Services at the US Naval Observatory (USNO). He received his undergraduate degree in Physics from MIT. His PhD was from U.C. Berkeley, and his thesis, under Charles Townes, involved building masers and using them for molecular radio astronomy and interferometry. Hired at the USNO in 1979, he measured Earth rotation and orientation using Connected Element Interferometry and Very Long Baseline Interferometry (VLBI). Beginning in the early 90's, he started working on atomic clocks and in 1997 was appointed Head of the USNO's Time Service Department. He has over 100 publications, has served on many international commissions, and for three years was President of the International Astronomical Union's Commission on Time. Email: [demetrios.matsakis@usno.navy.mil](mailto:demetrios.matsakis@usno.navy.mil);

Mr. Victor Shufang Zhang has a MS degree from the Electrical and Computer Engineering Department of University of Colorado. He has been with the National Institute of Standards and Technology (NIST) Time and Frequency Div. since 1989, working on various GPS and TWSTFT time and frequency transfer projects and time transfer link calibrations. He has served as a co-chair of the Civil GPS Service Interface Committee (CGSIC) timing subcommittee from year 2002 to year 2015. In September 2015, he is appointed as the chair of the CCTF

Working Group on Two-Way Satellite Time and Frequency Transfer. Email: [victor.zhang@nist.gov](mailto:victor.zhang@nist.gov);

Dr. Héctor Esteban entered the Naval Academy in 1992, becoming Lieutenant Junior Grade in 1997. On May 2001 he was assigned to the Royal Institute and Observatory of the Navy (ROA), and since 2005, he has been working in ROA Time Department. He is responsible for GPS time dissemination, processing, and calibration. In 2013 he received his Ph.D. degree focused on GNSS time and frequency transfer technologies and calibration techniques. Email: [hesteban@roa.es](mailto:hesteban@roa.es);

Dr. Dirk Piester received his diploma degree in physics and Dr.-Ing. degree from the Technical University Braunschweig. Since 2002, he has been with the Time Dissemination Group of the Physikalisch-Technische Bundesanstalt (PTB) where he is in charge of PTB's time services. His main research interests are improvements of time and frequency transfer technologies and calibration techniques via telecommunication and navigation satellites as well as optical fibers. In this framework two fellowships (in 2007 and 2010) were granted by the Japan Society for the Promotion of Science (JSPS). Dr. Piester has served as the president of the CCTF Working Group on Two-Way Satellite Time and Frequency Transfer from September 2009 to September 2015. He has authored or co-authored more than 80 papers in refereed journals and conference proceedings. Email: [dirk.piester@ptb.de](mailto:dirk.piester@ptb.de);

Mr. Shinn-Yan Lin was born in Taiwan, in 1967. He received the B.S. in physics and M.S degree in astronomy physics from the National Central University, Chung-Li, in 1990 and 1994. Then he entered the National Standard Time and Frequency Laboratory, Telecommunication Laboratories, Chungghwa Telecom Co. Ltd, Taiwan, as a Researcher. He works at the national standard time and frequency project and is in charge of the maintenance and improvement of the national standard time scale of Taiwan. His current research interests include timescale

algorithms, GNSS and Satellite time and frequency transfer, local time dissemination systems, and precise time and frequency measurements. Email: [sylin@cht.com.tw](mailto:sylin@cht.com.tw) ;

Mr. Erik Dierikx received the M.Sc. degree in electrical engineering, in 1995, from the University of Technology, Eindhoven, The Netherlands, working on "Low frequency noise in quantum well lasers". In 1995, he joined the Electricity and Magnetism section at VSL (the Dutch metrology institute), Delft, The Netherlands and specialized in low-frequency impedance measurements. In 2006, he became involved in the Time & Frequency section at VSL, contributing to a delay calibration system for a two-way satellite time and frequency transfer station. From 2012, he has been working on time and frequency transfer through optical fibers. Currently, he is responsible for the activities in the Time & Frequency section at VSL. E-mail: [edierikx@vsl.nl](mailto:edierikx@vsl.nl).

## ABSTRACT

Two-Way Satellite Time and Frequency Transfer (TWSTFT) links were first introduced to Coordinated Universal Time (UTC) generation in 1999. These TWSTFT links were calibrated by alignment with the corresponding GPS time links, of which the nominal uncertainty was 5 ns. In the past decade, the primary calibration technique for TWSTFT link calibrations was based on a TWSTFT mobile ground station (MS) with uncertainty at the level of 1 ns. The use of an MS for TWSTFT link calibration is limited by the availability of an MS, a common satellite transponder, transportation, and high cost. For example, due to the lack of a common transponder, a MS cannot be used for a stand-alone calibration of the NIST-PTB link (the link between the National Institute of Standards and Technology (NIST) and the Physikalisch-Technische Bundesanstalt (PTB)). Therefore, alternative techniques have been proposed and validated in recent years.

Investigations for improving GPS time link calibrations have been performed since 2008. In 2011 this triggered the International Bureau of Weights and Measures (BIPM) to carry out a pilot study on using GPS link calibrations for the UTC TWSTFT time links. The study concluded that a link calibration uncertainty of 1.5 ns is attainable. Based thereon, the 'TWSTFT Calibration Guidelines for the UTC Time Links' recognize the GPS link calibration as an alternative technique for the calibration of TWSTFT links.

In this paper, we first outline the new TWSTFT Calibration Guidelines for UTC Time Links (v3.0), which was approved at the 23<sup>rd</sup> meeting of the Consultative Committee for Time and Frequency (CCTF) Working Group on TWSTFT. It authorizes several techniques, including the GPS link calibration and the Triangle

Closure Calibration (TCC). Then we discuss the attainable uncertainty of the GPS calibration. Finally we provide in the Annex an example report of using a GPS calibrator for a typical UTC time link calibration based on the US Naval Observatory (USNO) and PTB, UTC(USNO)-UTC(PTB) TWSTFT link calibration. Here we describe the characteristics of BIPM's Measurement of Total Delay (METODE) Global Navigation Satellite System (GNSS) calibrator, its setup at a UTC laboratory, Lab(*k*), measurements, and its results. In this calibration, the GPS result differs from that of the TWSTFT MS by 0.9 ns with an uncertainty of 1.5 ns.

**Key words:** TWSTFT, GPS time link calibration, Calibration Guidelines, Uncertainty, TCC calibration, METODE,

## 1. INTRODUCTION

Two-Way Satellite Time and Frequency Transfer (TWSTFT) has been a primary technique contributing to the comparison of clocks and primary frequency standards in UTC generation for over one and a half decades. TWSTFT has proved to be the most accurate technique for time transfer measurements based on the exchange of radio frequency signals via satellites [1,2,9,19]. It is independent from and complementary with GPS time transfer, and the long-term stability of its calibration has been demonstrated in many cases [39]. In addition, quasi-real time data exchange and computations are currently operational.

The importance of TWSTFT has grown over the past few years, with the introduction into UTC computations of time-links based on a combination of TWSTFT and GPS carrier-phase time and frequency transfer with the Precise Point Positioning (GPSPPP) processing. This strategy combines the accuracy of the TWSTFT calibrations with the precision of the GPS carrier phase solutions while also minimizing the effect of diurnal variations seen in time transfer results in many TWSTFT links. It also brings greater importance to the need for systematic calibration and recalibration of TWSTFT links. Wider application is nevertheless recommended whenever possible, e.g. for GNSS link calibration.

Calibration is a key issue in the use of TWSTFT in the UTC generation. However, calibration of a TWSTFT link via GPS is the only practical means in some cases. The evaluated Type B uncertainty ( $u_B$ ) of the GPS link calibration has been reduced to 1.5 ns as reported by PTB, ROA, (Royal Institute and Observatory of the Navy, Spain), NICT (National Institute of Information and Communications Technology, Japan), NIM (National Institute of Metrology, Beijing China), INRIM (Istituto Nazionale di Ricerca Metrologica, Italy), TL (Telecommunication Laboratories, Taiwan) and BIPM [4,5,8,10-13,36]. The BIPM's GPS-based calibration

system (METODE) [6,14,20,23,26,27] was applied successfully to the UTC TWSTFT links NICT-PTB, NIM-PTB and TL-PTB.

Another novelty in the guidelines is triangle closure calibration (TCC) [18], which is approved as one of the formal calibration techniques to transfer the  $N-1$  UTC link calibrations in an  $N$ -point network to all the  $(N^2-3N+2)/2$  independent links. Several TCCs were performed in the recent years and the latest one was reported in Dec. 2015 [25]. W. Klepczynski highlighted the TCC as a milestone in the TWSTFT history [19].

The guidelines encourage simultaneous or cross calibrations using multi-techniques. This is helpful to evaluate the calibration uncertainty and to investigate the potential biases between the different techniques.

## 2. THE NEW TWSTFT CALIBRATION GUIDELINES AND THE VERSION EVOLUTION

A drafting group was created according to the recommendation of the 22nd TWSTFT annual working group meeting held in VNIIFTRI (All-Russian Scientific Research Institute of Physico-Technical Measurements), Mendeleev, Russia, September 2014 [24]. It consisted of:

- Task group: E. Dierikx (VSL), J. Hirschauer (USNO), Z. Jiang (BIPM), C. Lin (TL), A. Naumov (VNIIFTRI), D. Piester (PTB), V. Zhang (NIST).
- Independent reviewers were invited who had not participated in the drafting work: J. Achkar (OP), F. Arias (BIPM), and J. Galindo (ROA).
- Editor: BIPM publication officer R. Sitonn, for the English and metrological vocabulary
- Commenters: all TWSTFT working group (WG) members; Distinguished invited commenter, D. Matsakis (USNO)

The draft guideline takes three facts for granted:

- A calibration is based upon a full cooperation of the participants, including the UTC laboratory of TWSTFT participation stations (PS), the TWSTFT mobile station (MS) provider and the BIPM;
- A TWSTFT PS laboratory has the technical knowledge and experience to perform correctly a TWSTFT calibration under the guidelines, even if it does not specify the full technical details;
- The mandated part of the guidelines should be clear and simple without technical details<sup>1</sup>.

The task group worked out the first draft (V0) that was circulated to all the members of the TWSTFT WG for

<sup>1</sup> The completed guideline has only a master document of three effective pages plus two Annexes, which are not mandated but openly published. One is the annex of this paper and the other is [3]

comments, submitted to the TWSTFT PS meeting held during the PTTI in Boston in Dec 2014, handed to the independent reviewers, corrected by the BIPM publication officer, and submitted to the TWSTFT PS meeting during the IFCS-EFTF in Denver, April 2015. At every stage there were discussions and revisions; the deadline for final comments of all the members of the TWSTFT WG was 15 May. In total, 55 drafts were edited, and the final version (V3) was approved by the 23<sup>rd</sup> CCTF WG on TWSTFT meeting at BIPM on the 8 Sept, 2015.

This achievement is therefore a product of the full participation and cooperation of the whole community; however the TW calibration guidelines are a living document, and will be updated when necessary by the future annual CCTF WG on TWSTFT meetings.

## 3. THE CHARACTERISTICS OF THE NEW GUIDELINES

### 3.1 The Primary calibration technique

The primary calibration technique uses a standard TWSTFT mobile station (MS). The calibration uncertainty of using a MS is usually  $u_B \leq 1$  ns [2,3,15-16,22]. Reference [3] gives all the details about the organization, data processing, uncertainty evaluation to be included in the final report, and the CALR (link calibration result) implementation of the calibration campaign.

### 3.2 Alternative calibration technique

When use of the TWSTFT MS is not applicable, GPS time *link* calibration is an alternative technique, of which the uncertainty of 1.5 ns is attainable, as further described in the Annex and in [4,5,8,10-14,20,27,35-37].

The GPS *link* calibration differs from the *receiver* calibration. The latter is based upon a common clock difference (CCD) [20]. The *link* calibration measures the double clock difference (DCD) directly, which is calculated by subtracting the GPS *link* between the travelling calibrator and the remote site master receiver from the TWSTFT *link*. The local GNSS receivers of Lab( $k$ ) are not involved in the *link* calibration at all.

Meanwhile, a *link* calibration of either TWSTFT or GPS is referred to the UTC pivot point (PTB at present) while a *receiver* calibration is independent, keeping in mind that, theoretically, the UTC time transfer is a *link* time transfer between Lab( $k$ ) and PTB. In fact, the uncertainty in the UTC-UTC( $k$ ) values reported in the BIPM Circular T depends numerically on that of the time *link* of Lab( $k$ )-PTB, 98% on average [37].

Taking the example of the UTC link USNO-PTB, its TWSTFT part has been *link*-calibrated [30] while the GPS part is rather complex, because the USNO receiver is

regularly absolutely calibrated [33] whereas the PTB receiver was differentially calibrated against a BIPM travelling receiver traced back to an absolute calibration of 15 years ago [34]. Obviously, a bias may exist between the TWSTFT and GPS calibrations. The present difference between TWSTFT link and GPS link is 3.0 ns, <ftp://tai.bipm.org/TimeLink/LkC/1511/USNOPTB/Dlk/USNOPTB.T3T35.Gif>, given in the BIPM monthly time link comparisons of Nov. 2015. Both, the GPS *receivers* and TWSTFT *link*, have been calibrated in 2015, with the uncertainty values declared as 1.7 ns for the GPS *receiver* at PTB [31] and 0.6 ns for the TW *link* [30].

In summary, there are differences between, 1) the GPS *link* calibration aiming at calibrating a TW *link*; and 2) the GPS *link* calibration derived from the receivers' calibrations (namely the *time link alignment* in terms of the BIPM practices):

- In the first case, we visit the two end laboratories in a unique and shortest calibration tour and in the second case, separate calibration tours may take place in quite different years;
- In the first, we use the same travelling calibrator, operated by the same person/Lab and follow the same guideline which is not the case in the second<sup>2</sup>;
- In the first, the local master GPS receiver is not involved so that all its error sources due to its setup, sub-delay measurements, instabilities in it and in other related equipment will not affect the calibration;
- The first is a pure differential calibration and the second may be a mix of differential and absolute calibrations, as in the case of the UTC link USNO-PTB;
- Finally, in the first, the GPS-link and TWSTFT-MS-link calibrations have the same reference, that is, the pivot of the UTC network (PTB) which is fixed with respect to all the labs/links of TW and GPS, but in the second, some are referred to the average of the G1 and G2 laboratories, e.g. PTB, OP, NMIJ, etc. as given, e.g., in [31] (where the pivot PTB master receiver has a obtained correction) and other to an absolute one (USNO). In general, the end-points of the links (Lab(k)-PTB) may have different corrections made by different campaigns, epochs, calibrator and operator following different guidelines.

Taking the above as a fact and referring to a “rigorous” metrological calibration, the result of time transfers calibrated by *link* and *receiver* schemes are not directly

<sup>2</sup> For example, the VSL-PTB TW link was calibrated in 2013 using a MS [25] but that of the GPS master receiver at VSL was made in 2004 [38] using a C/A code calibrator and that of PTB was in 2015 using P3 code [31]. Even under the ongoing BIPM/RMOs G1-G1 calibration program, the receivers of PTB and VSL will be calibrated by different operators, travelling calibrators in different tours on different periods.

comparable [20]. The bias may be bigger than the uncertainty, as in the case above of USNO-PTB. A conversion between link and receiver calibration results would be necessary, which is often difficult to achieve due to the fact that there is not a unique, clear and traceable reference for the later. That is why, in case of a BIPM UTC calibration, an *alignment* of a TW link to a GPS link (obtained by a *receiver* calibration) is not considered as a metrological calibration of the same category, and a conventional value of 1 ns at least is added to the originally stated uncertainty of the GPS *receiver* calibration<sup>3</sup>.

Although the local GNSS receivers of Lab(*k*) are not needed in the TW link calibration, it is possible as a side-benefit to use the TW MS calibration to verify or determine the calibration of the GNSS link.

### 3.3 Other provisions of the guidelines

- Accept **TCC** (Triangle Closure Calibration) with an uncertainty evaluation for each case;
- Accept a UTC laboratory (not necessarily PTB) as the starting and closing point, with uncertainty evaluation for each case;
- Clarify the responsibility and relation of different parties between the MS provider; the participating laboratories; the coordinator, and the BIPM;
- Rather than the technical details, it outlines the organization, measurement, data processing, final report and CALR implementation.

## 4. THE CALIBRATION REPORT

A coordinator is named by the participants and charged with the preparation of the report, based on the input of the participants. For this purpose, the participants will provide the raw data and any other technical information relevant to the measurement. Sections 4.1 and 4.2 specify what the report contains.

### 4.1 MS calibration report contains

- The description of the calibration campaign;
- The technical protocol;
- A technical description of the common clock difference or link difference measurements performed at each station visited;
- Report of the results and their corresponding uncertainties;
- The measurement data processing for the computation of the calibration result (CALR), Earth station delay variation (ESDVAR) and their related uncertainties;

<sup>3</sup> The uncertainty of this so-called TW link *alignment* to the GPS link includes the uncertainties of the GPS receivers at both ends and additional components from reference delays for both the GPS receivers and the TW stations, giving an extra alignment uncertainty in the budget of the total uncertainty.

- The complete evaluation of the uncertainty budget;
- In cases where the pivot of the TWSTFT network does not participate in the campaign, the report must include result and uncertainty of the link between the selected intermediate station for the calibration and the pivot;
- In the case of calibration by TCC, a description of the method for evaluating the uncertainties is required.

The calibration report must be approved by all participating laboratories, and will be published on the BIPM website after approval.

The exact style is not mandated by these guidelines, but reference [3] is provided as an example to carry out the calibration and prepare the report.

#### 4.2 GPS link calibration report content

Using GPS to calibrate a TWSTFT link is a simple alternative to the use of a TWSTFT MS. Nevertheless, reporting the results is essential and all key points listed in subsection 4.1 should be adequately addressed. The annex of this paper is an example of a GPS time link calibration campaign and the calibration report. Its style is not mandated by the guidelines but is a reference to carry out a calibration and to prepare the report. Latest developments in improving the continuity of the GPS measurements [28,32] may further reduce the calibration uncertainty.

#### 5. NOTES:

- Any of the following stations can be used as the starting-closing station for a calibration campaign:
  - The pivot laboratory in the UTC time links network (PTB at present),
  - A UTC(*k*), i.e. any UTC TWSTFT station that is part of the calibration trip,
  - Other stations as decided by the TWSTFT working group;
- As an example, [3] gives the uncertainty of the closure measurement at the pivot or intermediate stations;
- The stability of the intermediate station needs to be guaranteed over the period of the calibration campaign. This could be achieved by performing repeated common clock measurements, by the use of a satellite simulator, and/or by comparison with the corresponding GPS measurements;
- Use of the TCC is authorised, cf. [18,25] for the detailed discussion on method and related uncertainty;
- If applicable, it is suggested that the TWSTFT link calibration be compared to the latest GPS calibrations. Considering the independence of the two techniques, the difference should be in agreement with the combined uncertainty:  $U \leq \sqrt{[u^2(\text{TW})+u^2(\text{GPS})]}$ . If this is not the case, an analysis of the causes is recommended;

- The implementation of the calibration results will be decided by the participants and the BIPM.

#### 6. THE ROLE OF THE BIPM

The role of the BIPM is:

- To verify that reports respect the Guidelines for UTC time links, and to approve and publish it on the BIPM website;
- To assign a Calibration Identification (CI) number to each accepted Result (CALR);
- To propose the date of implementation of the calibration results in the ITU data files in agreement with the participants (coordinated by the concerned members of the TWSTFT WG). The implementation of calibration results should be made, by preference, within the two months following the assignment of the CI numbers. To facilitate the calculation of Circular T, the date of implementation of calibration results should be fixed between two periods of calculation of Circular T, on a Modified Julian Date (MJD) date not ending in 4 or 9;
- To monitor the stability of UTC time link calibrations through the monthly comparisons between the TWSTFT and GPS time transfer links. The comparison results are monthly published at <http://tai.bipm.org/TimeLink/LkC/>. As a supplement to the laboratories monitoring their systems and links, the BIPM will contact the relevant laboratories if anomalous behaviour is apparent;
- To perform the global network calibration through TCC [18,21,25] when necessary;
- To report to the CCTF Working Group on TWSTFT on the status of the time link calibrations.

The members of the CCTF Working Group on TWSTFT and the BIPM are responsible for keeping the Guidelines up to date. Discussions will be ongoing, but final approval of any changes will take place at the annual TWSTFT meetings.

#### ACKNOWLEDGMENTS

The authors are grateful to the TWSTFT colleagues for their technical supports and close cooperation, in particular the participants of and the contributors to the BIPM Pilot Project on the UTC Time Links calibration from AOS, BIPM, BSNC, NIST, NICT, NIM, NMIJ, OP, PL, PTB, ROA, TL, and USNO. We thank also Andreas Bauch (PTB) and Brian Luzum (USNO) for their helpful comments and careful corrections during the preparation of the final manuscript.



ANNEX. Example report [29]

# TWSTFT link calibration report

-- Calibration of the Lab( $k$ )-PTB UTC Time Links with a GPS calibrator<sup>4</sup>

## Abstract

This report includes the calibration results of the Lab( $k$ )-PTB TWSTFT link and closure measurements of the BIPM-Lab( $k$ )-BIPM tour. During 10-20 Feb., 2015 (DOY 41-51, MJD 57063-57073), the BIPM Standard Travelling Calibration Station ( $Std_B$ ) visited Lab( $k$ ) in order to calibrate the Lab( $k$ )-PTB TWSTFT link for UTC generation. This work follows the TWSTFT Calibration Guideline for UTC Time Links [26].



Photos: The calibration setup at Lab( $k$ )

## NOTATION

**UTC<sub>p</sub>**: the UTC( $k$ ) point at Lab( $k$ ). Hereafter the  $k$  stands for Lab( $k$ ), the laboratory to be calibrated

**Link**: a time link is a clock comparison result using a particular technique, e.g., a link of GPS C/A, P3, PPP or GLONASS or TWSTFT or TWOTFT. A UTC link at present is a time link between Lab( $k$ ) and PTB

**Std<sub>B</sub>**: The BIPM GPS travelling calibrator, consisting of  $N$  ( $\geq 2$ ) GNSS receivers+antennas+cables and PPS/frequency-distributors. It is a pre-cabled black box calibrator with unknown but constant total delay during a calibration tour

**Total Delay**: The total electrical delay from the antenna phase center to the UTC<sub>p</sub> including all the devices/cables that the satellite and clock signals pass through. It numerically equals the sum of all the sub-delays. The total delay uncertainty is the main part of the UTC time transfer uncertainty

**METODE**<sup>5</sup>: MEasurement of Total Delay, the BIPM calibration system composed of related methods

<sup>4</sup> This Annex gives a general example how to perform a TWSTFT link calibration of Lab( $k$ )-PTB with a GPS calibrator and prepare the report. Although the report is partially based on the calibration experiment at USNO [23], the acronyms (BIPM, USNO, PTB etc.), coordinator, equipment, images, figures, measurement data etc. in this document are *fictional*.

<sup>5</sup> METODE was proposed in the frame of the BIPM pilot project (2011-2014) aiming at unifying the UTC time link calibration with an uncertainty  $\leq 2$  ns [6,20,27]. It is composed of a time link calibration scheme with the calibrator denoted Std<sub>B</sub>.

This document describes a typical TWSTFT link calibration. If we replace the TWSTFT link by a GNSS link or an optical fiber (OF), it becomes a GNSS or an optical fiber (OF) time link calibration. This calibration becomes a classic receiver calibration if the link includes the UTC network pivot (PTB), whose absolute calibration error will be cancelled UTC time transfer. The calibration correction  $C_M$  can be converted to classical corrections of the Internal Delay, INTDLY(L1/L2), by removing the CABDLY and REFDLY. However, this introduces extra uncertainties. In consequence, the uncertainties of the INTDLY(L1/L2) maybe larger than 3 ns [13,27].

and equipment ( $\text{Std}_B$ ) for the generation of UTC-UTC( $k$ ) in Circular T [1]

$C_M$ : The METODE total delay correction. It should be *subtracted* from the GPS data, e.g. RefGPS- $C_M$  in CGGTTS, - $C_M$  in Clb\_GNSS.Lst file; and *added* to the CALR of the ITU TWSTFT data of the Lab( $k$ ) side file LabKMJ.DDD. If the PTB is taken as the reference of the calibration, a GNSS time *link* correction is equal to the differential GNSS *receiver* calibration correction

$u_A, u_B$ : Type A and type B uncertainties ( $1-\sigma$ ) [16,17]

$u_M$ : Total uncertainty of the total delay correction  $C_M$ ;

**CCD**: Common clock difference

**DCD**: Double clock difference, e.g. link difference of TWSTFT and GPS

**Tour**: a calibration *tour* is a round trip calibration campaign with start and closure measurements. It may include several laboratories

## A1. SUMMARY

According to the TWSTFT calibration guideline for UTC time links [7,26], a TWSTFT link calibration campaign is carried out using a mobile TWSTFT ground station or/and a GPS calibrator that are circulated among several time laboratories contributing to UTC. This report confines itself to the specific measurement of Lab( $k$ )-PTB. A similar calibration tour of NIST-PTB has been made. The consistency of that report with previous TWSTFT calibrations of the Lab( $k$ )-PTB and Lab( $k$ )-NIST links will be presented elsewhere.

### A1.1 General

This report includes the calibration results of the Lab( $k$ )-PTB TWSTFT link and closure measurement of the BIPM-Lab( $k$ )-BIPM tour with the BIPM standard travelling calibration station ( $\text{Std}_B$ ). During 10-20 Feb., 2015 (DOY 41-51, MJD 57063-57073), the  $\text{Std}_B$  was installed at Lab( $k$ ). The goal was to calibrate the Lab( $k$ )-PTB TWSTFT link for UTC generation. This work and this report follow the TWSTFT Calibration Guideline for UTC Time Links [7].

As part of the BIPM Pilot Project, the METODE was developed to unify the UTC time link calibrations with a calibration uncertainty  $u_B \leq 1.5\text{--}2$  ns [6,27]. Since 2013, the  $\text{Std}_B$  has visited the UTC labs OP, PTB, PL, AOS, TL, NMIJ, NICT, NIM (BSNC), and ROA; experiments were made also at the BIPM, NIST, USNO [23] and Lab( $k$ ). The three  $\text{Std}_B$  visits to PTB in June 2013, Aug. 2014 and April 2015 allow transferring the calibration of the PTB master receiver to the Lab( $k$ ). The differences of the two visits were less than 0.3 ns. This and the closure measurements at BIPM proved the long-term stability of the  $\text{Std}_B$ .

The requirements for the setup and computations can be

found in the BIPM calibration guideline [26]. Accounting for the starting and closure measurements at the BIPM, we compute the calibration corrections for the UTC TWSTFT time links between Lab( $k$ )-PTB. Since this link has been recently calibrated with TWSTFT, this supplies a supplementary and official GPS time link calibration.

GPSPPP solutions are used for this calibration.

### A1.2 Summary of the main result

Table A1 displays the calibration for the time link corrections ( $C_M$ ) for the TWSTFT links on the baseline Lab( $k$ )-PTB, see Table A1.

**Table A1** The total delay correction for the TWSTFT time link Lab( $k$ )-PTB

Lab	Time Rev/Link	$C_M/\text{ns}$	$u_M$	ITU CI	S
Lab( $k$ )	TWSTFT: Lab( $k$ )-PTB	+0.9*	1.5 ns	888-2015	1

\* In the files TWLABK57.070, and TWPTB57.070, we have the corresponding CALR=-488.0 ns for Lab( $k$ ) and +488.0 ns for PTB. The ESDVARs= are kept zero and unchanged, cf. Section 4.2.

Figure A1 shows the data of the related links. Of the available GPSPPP links, only USN6-PTBB is illustrated here. As shown in the plot, the Lab( $k$ )-PTB TWSTFT and the GPSPPP links are close to each other but 0.9 ns and 1.5 ns lower than the  $\text{Std}_B$ -PTBB link.

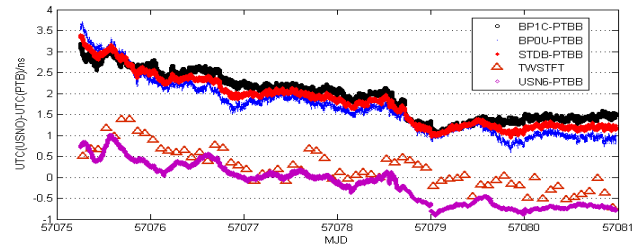

**violet**: PPP Lab( $k$ )-PTB; **Triangle**: TWSTFT Lab( $k$ )-PTB; **Red**: PPP  $\text{Std}_B$ -PTBB ( $\text{Std}_B$  is mean of BP0U/blue and BP1C/black)

**Figure A1** The time links on the UTC baseline Lab( $k$ )-PTB during the calibration period

### A1.3 The Combined Uncertainty

The *total uncertainty* ( $U_M$ ) of the  $C_M$  is composed of [27]:

- PPP Measurement uncertainty ( $u_A$ ) of  $\text{Std}_B$ -UTC( $k$ ): 0.1~0.3 ns;
- PPP Measurement uncertainty ( $u_A$ ) of UTC( $k$ )-UTC(PTB): 0.1~0.3 ns
- TWSTFT Measurement uncertainty ( $u_A$ ) of UTC( $k$ )-UTC(PTB): 0.2~0.5
- Instability and the sub-delay measurement uncertainty of the reference at Lab( $k$ ): 0.5~0.7 ns
- Instability of the traveling receivers: 0.5~1.0 ns;
- Others (including multipath): 0.3~0.6 ns

The  $U_M$  as estimated from the root mean square (RMS) of

these errors is hence 0.8~1.5 ns ( $1\sigma$ ). However, the unknown and systematic errors are likely higher than usual and therefore we take our uncertainty to be 1.5 ns.

If only one GPS receiver calibrator component of the METODE is used, the instability would be factor of  $\sqrt{2}$  higher, and  $u_B = \sqrt{2} \times 1.5 \text{ ns} = 2.1 \text{ ns}$ .

Other independent studies [4,5,10-13,36] proved that the calibration uncertainty of 1.5 ns or even smaller [10] is attainable. Here each *system* can perform a calibration without sharing any common part with the other. It is best to have at least two receivers of different types. This may increase the measurement discrepancies but lowers the uncertainty computation as well as the robustness of the calibration result.

## A2. STANDARD SETUPS OF THE $\text{Std}_B$ DURING A CALIBRATION TOUR

The setup of the  $\text{Std}_B$  is shown in Figure A2. The cable C166 was directly connected to the UTC( $k$ ).

By the definition of the METODE UTC time link calibration correction [6], we have the following steps:

- We start from BIPM;
- We set the PTB's master GPS receiver (PTBB) as the reference of the calibration and its calibration correction to be zero;
- We align the  $\text{Std}_B$  to PTBB, i.e. the BP0U and BP1C in  $\text{Std}_B$  are to be corrected -5.2 ns and -3.6 ns [27];
- The  $\text{Std}_B$  goes to the Lab( $k$ ), and makes measurements side by side with the TWSTFT ground station of Lab( $k$ ). They use the same reference signals of UTC( $k$ );
- We make the closure measurement at BIPM;
- We compute the double clock differences (DCDs) as shown in equation (1) below. Each data point is the result of the difference of a TWSTFT value and the interpolation of the 2 adjacent PPP values (computed every 5 min) or P3 values (computed about every 16 min). P3 technique is not the best option to carry out DCD, even worse for long baseline, nevertheless the differences with respect to PPP results are normally below 0.5 ns. The corresponding equation for the DCD is:

$$\begin{aligned} C_M = \text{DCD} &= \text{Link}(\text{PPP}) - \text{Link}(\text{TW}) \\ &= [\text{UTC}_{\text{PPP}}(k)_{\text{Std}_B} - \text{UTC}_{\text{PPP}}(\text{PTB})] \\ &\quad - [\text{UTC}(k) - \text{UTC}(\text{PTB})]_{\text{TW}} \end{aligned} \quad (1)$$

here the GPSPPP data in the first bracket are taken while  $\text{Std}_B$  is at site  $k$ . The  $\text{UTC}_{\text{TW}}(k)$  is measured by the TWSTFT equipment; the no-zero DCD is the calibration correction to the link Lab( $k$ )-PTB.

To average out the diurnal effects and measurement noise, 5 to 7 days of continuous measurements are required.

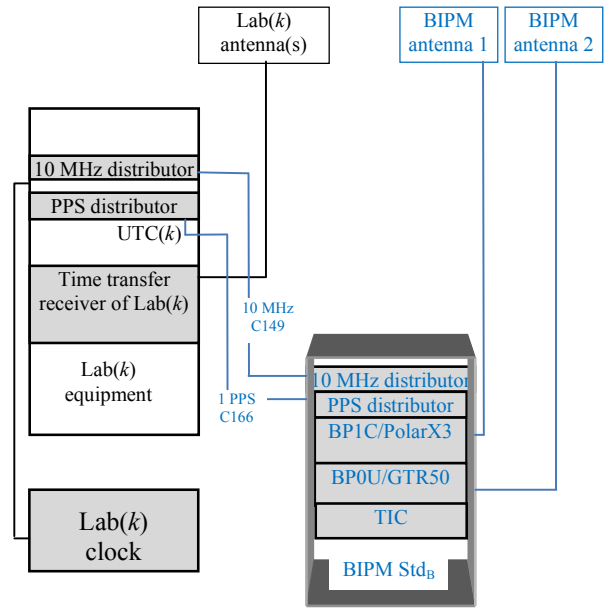

**Figure A2** Setup of the BIPM  $\text{Std}_B$  at a UTC( $k$ ) (The BIPM devices including cables are shown in blue. Lab( $k$ )'s equipment is shown in black)

## A3. SETUPS AT THE LAB(K)

The setup and the 1-PPS IN/OUT measurements at Lab( $k$ ) are illustrated in Figures A3.1 and A3.2. See also the photos on the cover page. The RefDly determination is critical, and is the only value that must be measured in both laboratories. Although not difficult in principle, subtle impedance matching issues, reflections, and even the choice of measurement technique could affect the measurement. In the BIPM  $\text{Std}_B$ , a time interval counter (TIC) is used to reduce the impact of the bias in the sub-delay measurements (Figure A3.2). In the setup of Figure A3.1, the RefDly of the  $\text{Std}_B$  is 66.2 ns.

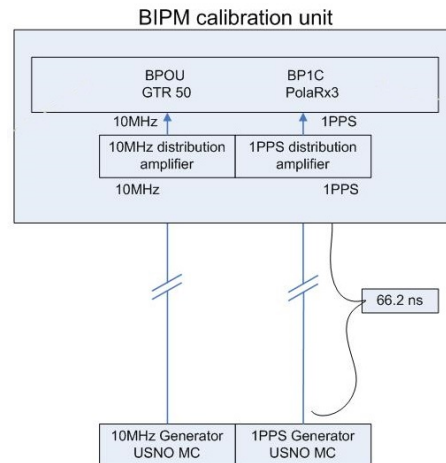

**Figure A3.1** Setup of the  $\text{Std}_B$  at the Lab( $k$ ) T/F laboratory



Figure A3.2 shows the BIPM BP1C PPS IN/OUT measurement on 10/2/2015 before the calibration measurement started. On 20/2/2015, another measurement was made after the measurement. The difference was 0.05 ns and is negligible.

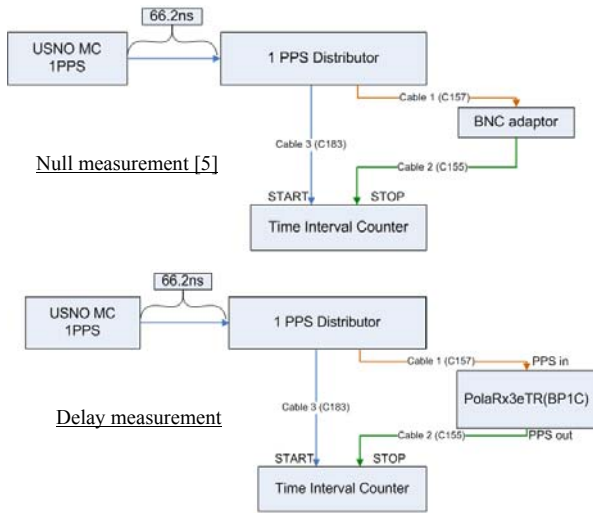

**Figure A3.2** BIPM BP1C PPS IN/OUT measurements

Table A3.1 is a summary of the receiver and the antenna information directly used in the calibration data processing. Table A3.2 lists the present sub-delays before the calibration. They will be used as the starting values for the calibration computations.

**Table A3.1** The receiver and antenna information

Receiver	Type	Antenna	Antenna code	Note
BP0U	GTR50	NOV702GG	NAE07190046	BIPM Std <sub>B</sub>
BP1C	Sept. Polarx3	ASH701945E_M	2000785	BIPM Std <sub>B</sub>
PTBB	Ashtech Z12T	ASH700936E SNOW	CR15930	Master

**Table A3.2** The sub-delay information (in CGGTTS header etc.) /ns

Rcv	Int-Dly (L1)	Int-Dly (L2)	Int-Dly (L3)	Cab Dly	Ref-Dly**	Co*	C1*	C2*	C3*	Total Dly
BP0U					-66.2	-20.8	5.2			-81.8
BP1C					-66.2	225.2	3.6	203.3	-6.5	-47.2
PTBB	304.5	318.9	282.252	301.7	75.3					508.65

\* Co, C1, C2, C3 are the sub-delays/corrections. We use only the Total Delay for the link calibration

## A4. DATA REDUCTION AND ANALYSIS

We use the equation (1) to compute the total delay calibration correction  $C_M$  through the DCD of the TWSTFT and the GPSPPP links.

### A4.1 GPSPPP solution

The RINEX files (including PTBB) were edited and corrected for cycle slips with the program of Teqc before the PPP processing. For the Novatel receiver, the bias C1-P1 was taken into account using the program of CC2nonCC.

The red triangles in the following figures are the day-averaged values.

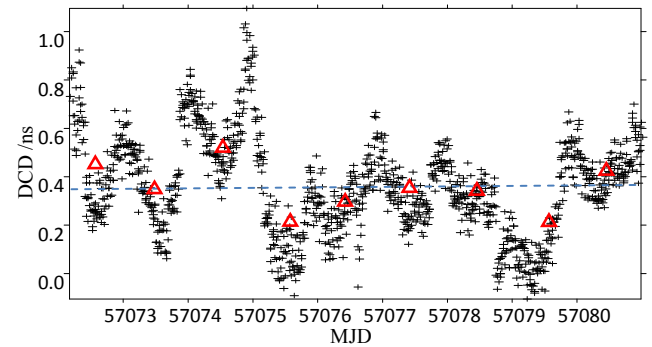

**Figure A4.1a** DCD of BP1C-BP0U,  $A_v=0.357\pm0.200$  ns

Figures A4.1a and A4.1b show the DCD of the BP0U and BP1C and the TDev. The measurements show an effect of unknown origin [23]. The DCD scatter up to 1 ns. Although most of the deviations should be averaged out, the possibility of a systematic bias in one of the two receivers cannot be ruled out by divided by 2. The mean value is  $0.357\pm0.200$  ns.

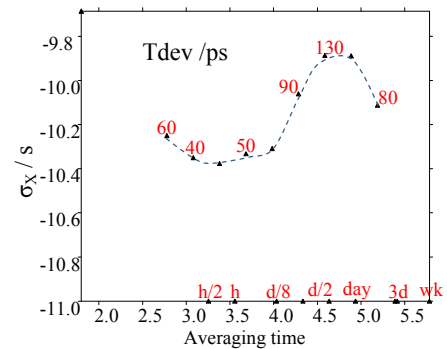

**Figure A4.1b** Tdev of the DCD in Figure A4.1a

### A4.2 The calibration of the TWSTFT link

The raw data of the GPS and TWSTFT between MJD 57075-57081 were used.

Figures A4.2a and A4.2b depict the CCD and DCD of the TWSTFT minus GPSPPP links over the baseline Lab(k)-PTB. Here and below, the black cross is TW link and blue circle the PPP link. The DCD, i.e., the calibration corrections, are 0.79 ns and 1.07 ns as measured by the BP0U and BP1C respectively. Their average TWSTFT link calibration correction is  $C_M=0.93$  ns with an

uncertainty of 1.5 ns. If applied, it should be added to the CALR in the ITU file on the Lab(*k*) side and subtracted from the PTB ITU file.

From the ITU file TWLABK57.070, CALR= -488.884 ns and ESDVAR=0.0±0.0 ns. We have then the METODE calibrated CALR=-488.88 ns+(0.93 ns)=-487.95 ns with ESDVAR=0, which is unchanged in both sides of PTB and Lab(*k*).

This correction should be *subtracted* from the ITU TWSTFT data format file of the PTB side but *added* to that of Lab(*k*) side. The Job of the BIPM Tsoft Menu Y20 for this calibration correction (active Calib) is:

```
LAB1 LAB2 CALR ESDVAR !CALR=-488.0=-488.9+0.9/ITU
PTB01 LABK01 +488.0 0.0 !subtracted from ITU TWPTBmj.ddd
LABK01 PTB01 -488.0 0.0 !added to ITU TWUSNOmj.ddd files
```

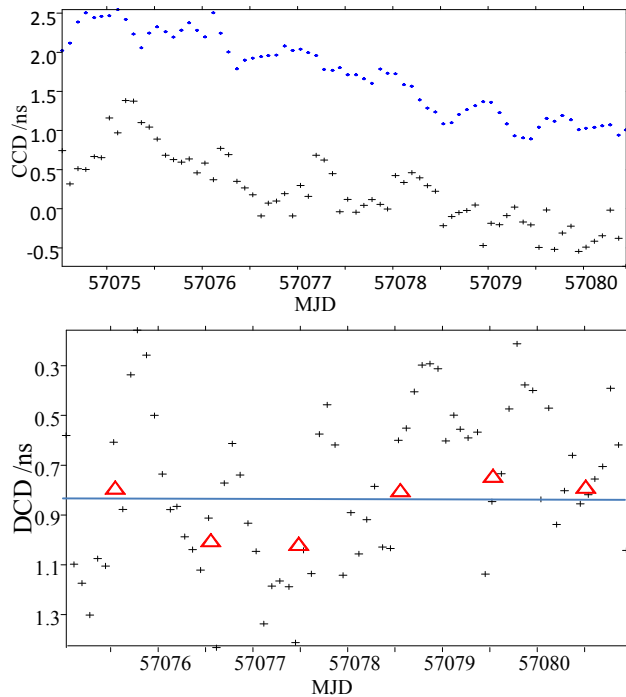

**Figure A4.2a** DCD of TWSTFT and PPP (*BP0U*-PTBB) links of Lab(*k*)-PTB,  $A_v=0.79\pm0.309$  ns

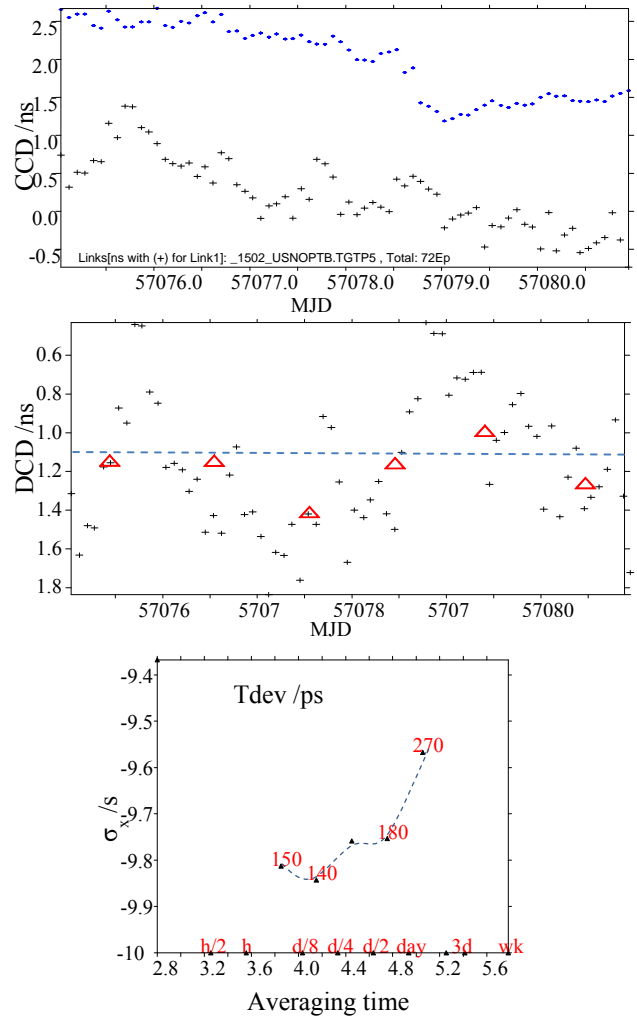

**Figure A4.2b** DCD of TWSTFT and PPP (*BPIC*-PTBB) links of Lab(*k*)-PTB,  $A_v=1.07\pm0.339$  ns

Note that, usually the ESDVAR should be set to zero after calibration. The calibration identifier CI is 394.

### A4.3 The TWSTFT and GPSPPP links after the calibrations

The calibration of the GNSS time transfer facility is not the goal of this calibration tour. We give the following GPSPPP and TWSTFT time link comparison result only as complementary information.

Figure A4.3 shows the TWSTFT and GPSPPP links after the new CALR(Lab*k*)= -488.0 ns (ITU CI=394/ S=1) and the new INTDLY(L3) = +1.5 ns are applied, cf. Table A1 and [23]. The mean of the differences is 0.044 ns ±0.284 ns. Diurnals in both GPSPPP and TWSTFT present as shown in the Figure A4.3.

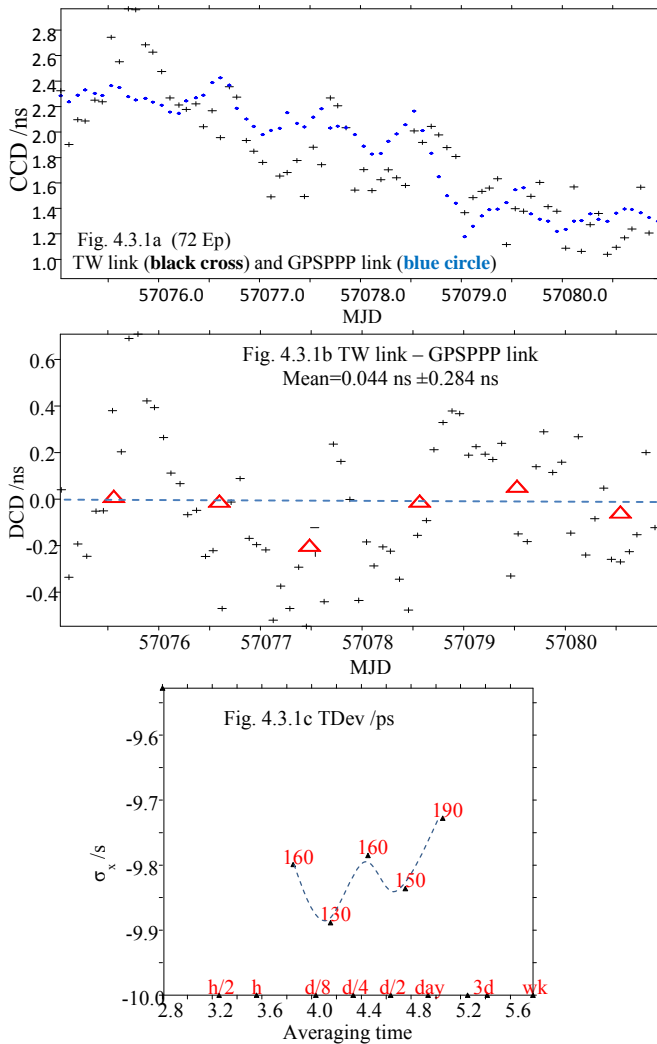

**Figure A4.3** DCD of Lab(*k*)-PTB link comparison. Both TW and PPP links are calibrated

## A5. STABILITY OF $\text{Std}_B$ AND CLOSURE AT BIPM BEFORE/AFTER THE LAB(*K*) TOUR

**Table A5.1** The PPP closures at BIPM before and after the visits to Lab(*k*) vs. the GTR50 BP0T

Period	BP0U -BP0T /ns	BP1C -BP0T /ns	BP1C -BP0U /ns	Mean vs. BP0T /ns
57050-57056	-0.4±0.2	0.0±0.2	0.4±0.2	-0.2±0.2
57090-57096	-0.2±0.2	0.2±0.2	0.4±0.2	-0.0±0.2
Old-New closure	-0.2	-0.2	0.0	-0.2

The final computation should be made after the closure measurement which controls the stability of the  $\text{Std}_B$ . Table A5.1 gives the GPSPPP closures at BIPM before and after the visit to Lab(*k*). The stationary BIPM receiver GTR50 BP0T is taken as a reference. On average, the closure of the  $\text{Std}_B$  is -0.2 ns for the two receivers and is negligible. The two travelling receivers in the  $\text{Std}_B$  are

separated by 0.4 ns. The  $\text{Std}_B$  is stable during the calibration tour.

The instability of the  $\text{Std}_B$  is no bigger than 0.5 ns since its last visit to PTB in Aug. 2014.

## REFERENCES

- [1] Jiang Z., Konaté H., and Lewandowski W. (2013) Review and Preview of Two-way Time Transfer for UTC generation – from TWSTFT to TWOTFT, Proc. EFTF, July 2013, Prague
- [2] Piester D., Bauch A., Breakiron L., Matsakis D., Blanzano, B., Koudelka O. (2008) Time transfer with nanosecond uncertainty for the realization of International Atomic Time, Metrologia, vol. 45, no. 2, 185-198
- [3] Galindo F. J. et al. (2016) On the TWSTFT Mobile Station Calibration - European TWSTFT Calibration Campaign 2014 for UTC(*k*) laboratories in the Frame of Galileo FOC TGVF, in Proc. PTTI2016
- [4] Esteban H., Palacio J., Galindo F. J., Feldmann T., Bauch A., Piester D. (2010) Improved GPS-Based Time Link Calibration Involving ROA and PTB, IEEE Trans. UFFC, vol. 57, no. 3, pp. 714-720
- [5] Feldmann T., Bauch A., Piester D., Rost M., Goldberg E., Mitchell S., and Fonville B. (2011) Advanced GPS-Based Time Link Calibration with PTB's new GPS Calibration Setup, Proc. 42nd Annual Precise Time and Time Interval (PTTI) Systems and Applications Meeting, Reston, USA, pp. 509-526
- [6] Jiang Z., Arias F., Lewandowski W., Petit G. (2011) BIPM Calibration Scheme for UTC Time Links, Proc. 2011 Joint Conference of the IEEE International Frequency Control Symposium & European Frequency and Time Forum, Hyatt Regency, San Francisco, May 2-5, 2011, San Francisco, California (2011), pp 1064-1069
- [7] TWSTFT Calibration Guidelines for UTC Time Links (v3.0) (2015), available on BIPM restricted web site: [http://www.bipm.org/wg/CCTF/WGTWSTFT/Restrictive/WG\\_23rd\\_Meeting/TW\\_CLB\\_Guideline2015-V3.0\\_Final.pdf](http://www.bipm.org/wg/CCTF/WGTWSTFT/Restrictive/WG_23rd_Meeting/TW_CLB_Guideline2015-V3.0_Final.pdf)
- [8] Esteban H., Zhang V., Piester D., Matsakis D., Lin S.Y., Jiang Z.H., (2015) BIPM TM251: TWSTFT link calibration report - Calibration of the Lab(*k*)-PTB UTC Time Links with a GPS calibrator
- [9] ITU-R TF.1153-3 (2010) The operational use of Two-Way Satellite Time and Frequency Transfer employing pseudorange noise codes.
- [10] Esteban H., Galindo F. J., Bauch A., Polewka T., Cerretto G., Costa R., Whibberley P., Uhrich P., Chupin B., Jiang Z. (2015) GPS Time Link Calibrations in the Frame of EURAMET Project 1156, Proc. IFCS-EFTF2015, April 2015, Denver, USA
- [11] Cerretto G., Esteban H., Pallavicini M., Pettiti V., Plantard C., Razeto A. (2012) Measurement of CNGS Muon Neutrinos Speed with Borexino: INRIM and ROA Contribution. Proc. 44th Annual Precise Time and Time Interval (PTTI) Systems and Applications

- Meeting, Reston, Virginia, USA, pp. 133 - 140, 2012
- [12] Liang K., Feldmann T., Bauch A., Piester D., Zhang A., Gao X. (2011) Summary of the Link Calibration between NIM and PTB Using a Traveling GPS Receiver, Proc. 2011 Joint Conference of the IEEE International Frequency Control Symposium & European Frequency and Time Forum, May 2 - 5, 2011, San Francisco, California, USA, pp. 280 – 285
- [13] Lin Calvin S.Y., Huang Y. J., Tseng W. H. (2014) Upper Limit Uncertainty Estimation of TL METODE Calibration Tour Using Moving Cs Clock Method, Proc. ION PTTI 2014
- [14] Jiang Z., Czubla A., Nawrocki J., Lewandowski W. and Arias F. (2015), Comparing a GPS time link calibration to an optical fibre self-calibration with 200 ps accuracy, 2015 *Metrologia* **52** 384
- [15] Piester D., Bumgarner R., and McKinley A. (2014) The June 2014 calibration of the link UTC(USNO) – UTC(PTB) by means of the USNO portable X-band TWSTFT station, presented to the 22nd CCTF Working Group on TWSTFT, VNIIFTRI, 15-16 Sept. 2014, Mendeleev, Russia
- [16] JCGM 106:2012 Evaluation of measurement data – The role of measurement uncertainty in conformity assessment.
- [17] JCGM 200:2012 International vocabulary of metrology – Basic and general concepts and associated terms (VIM) 3rd edition.
- [18] Jiang Z., Lewandowski W., Piester D. (2008) *Calibration of TWSTFT Links Through the Triangle Closure Condition*, Proc. 40<sup>th</sup> Annual Precise Time and Time Interval (PTTI) Systems and Applications Meeting, 1-4 Dec 2008, Reston, Virginia, USA, pp. 467-483
- [19] Klepczynski W. (2014) TWSTFT: *It's History, Evolution and People*. Invited talk in the Opening Session of the *Precise Time and Time Interval (PTTI)*, 1-4 Dec. 2014, Boston, Mass. USA
- [20] Jiang Z. (2015) Link calibration or receiver calibration for accurate time transfer? Proc. *EFTF/IFCS2015*, April, Denver, US
- [21] Jiang Z., Lewandowski W., Harmegnies A., Piester D., and Zhang V. (2015) Restoration the TWSTFT link calibration using GPSPPP bridging after the satellite change on MJD 55769/27, July 2011, BIPM TM198bis
- [22] Bauch A., Piester D., Fujieda M., Lewandowski W. (2011) Directive for operational use and data handling in two-way satellite time and frequency transfer (TWSTFT), Rapport BIPM-2011/01, BIPM
- [23] Metchil S., Power E., Matsakis D., Tisserand L., Wu W., Petit G., Arias F. and Jiang Z. (2015) UTC link calibration report -- *MEasurement of TOveral DELay for UTC Time Link Calibration* Phase XI: USNO, BIPM, TM248
- [24] Dierikx E. and edited by Jiang Z. (2014) REPORT OF THE 22nd MEETING OF THE CCTF WORKING GROUP ON TWSTFT, 15-16 Sep. 2014, Mendeleev, Russia, available on BIPM restricted web site: <http://www.bipm.org/wg/CCTF/WGTWSTFT/Restricted/welcome.jsp>
- [25] Jiang Z. et al. (2016) TWSTFT Triangle Closure Calibration – BIPM 2015 calibrations for UTC and non-UTC time links, submitted to Proc. EFTF 2016
- [26] BIPM guideline for UTC time link calibration V2.2 draft 2/2014, BIPM TM228
- [27] Jiang Z. et al. (2016) Final report of the BIPM Pilot Study on UTC time link calibration, in Proc. PTTI2016
- [28] Yao J., Skakun I., Jiang Z. and Levine J. (2015) Revise Rinex-Shift, (2015) A Detailed Comparison of Two Continuous GPS Carrier-Phase Time Transfer Techniques, 2015 *Metrologia* **52**
- [29] Esteban H., Zhang V., Piester D., Matsakis D., (Calvin) Lin S.Y., and Jiang Z. (2015) TWSTFT link calibration with a GPS calibrator BIPM TM251
- [30] Piester D., Bumgarner, R., Wright J., McKinley A., Bauch A. (2015) Report of The July 2015 calibration of the link UTC(USNO) – UTC(PTB) by means of the USNO portable X-band TWSTFT station
- [31] BIPM calibrations of time transfer equipment (2015), <http://www.bipm.org/jsp/en/TimeCalibrations.jsp>
- [32] Yao J., Levine J. and Weiss M. (2015) Toward Continuous GPS Carrier-Phase Time Transfer: Eliminating the Time Discontinuity at an Anomaly, Journal of Research of the National Institute of Standards and Technology, Volume 120 (2015) <http://dx.doi.org/10.6028/jres.120.017>
- [33] Personal communications with D. Matsakis and E. Powers etc.
- [34] Petit G., Jiang Z., White J., Beard R., Powers E., “Absolute calibration of Ashtech Z12-T GPS receiver”, *GPS Solutions* 4 (4), 41, 2001b.
- [35] Rost M., Piester D., Yang W., Feldmann T., Wübbena T., Bauch A. (2012) Time transfer through optical fibers over a distance of 73 km with an uncertainty below 100 ps, *Metrologia*, 49 (6), pp. 772-778
- [36] Feldmann T., Bauch A., Piester D., Alvarez P., Autiero D., Serrano J., Brunetti G. (2012) Relative Calibration of the Time Transfer Link between CERN and LNGS for Precise Neutrino Time of Flight Measurements, Proc. 44<sup>th</sup> Precise Time and Time Interval (PTTI) Systems and Applications Meeting , 26-29 Nov 2012, Reston, VA, USA, pp. 141-150
- [37] Jiang Z. and Lewandowski W. (2014) An Approach to the Uncertainty Estimation of [UTC-UTC(*k*)], Proc. ION/PTTI2014, pp 79-85
- [38] [www.bipm.org/utis/common/pdf/rapportBIPM/2008/01.pdf](http://www.bipm.org/utis/common/pdf/rapportBIPM/2008/01.pdf), BIPM Calibration report (2008) Determination of the differential time corrections for GPS equipment located at the OP, PTB, NPL and VSL
- [39] Piester D., Achkar J., Becker J., Blanzano B., Jaldehag K., de Jong G., Koudelka O., Lorini L., Ressler H., Rost M., Sesia I., Whibberley P. (2006) Calibration of six European TWSTFT earth stations using a portable station, Proc. EFTF2006