

February 22, 1935.  
(Replaces Letter Circular 404).

Information Section  
National Bureau of Standards  
Washington, D. C.

METHODS OF USING STANDARD-FREQUENCY RADIO EMISSIONS

This pamphlet gives methods of frequency measurement for utilizing the standard frequencies disseminated by radio by the National Bureau of Standards. The pamphlet is in three parts.

Part 1 gives methods of using the emissions for the calibration of standard oscillators in simple cases where the frequencies have such numerical values as to be readily checked directly in terms of the emissions. The information is given specifically in terms of measurements upon the 5000-kc emissions, but there should be little difficulty in applying the methods to the 10,000-kc and 15,000-kc emissions. Higher harmonics of the auxiliary generator are involved. Further amplification or a doubling or other suitable increase in the frequency of the auxiliary generator should enable one to use any of the emissions after some trial and adjustment of equipment.

Part 2 gives specific information for the use of the emissions to check with great accuracy the frequency standard used in any broadcasting station (e.g., the monitor required by F.R.C. Rule 145). The discussion is divided into three sections, A, B, and C, progressing in difficulty of measurement. Section A deals with two frequencies, 1000 and 1250 kc/s; very little apparatus is required for measurements at these frequencies. Section B gives the method of measurement, using an auxiliary generator, for frequencies which are multiples of 50 kc/s. Section C gives the method of measurement for any broadcast frequency (multiples of ten).

Part 3 is a bibliography, in which references to other methods of frequency measurement may be found, and devices for use in frequency measurements are described. The references give other methods, which range from those using very simple apparatus, giving results only moderately accurate, to methods using complicated apparatus giving results accurate to better than a part in a million.

The Standard Frequency Emissions.- The National Bureau of Standards transmits standard frequencies from its station WWV, Beltsville, Md., near Washington, D. C.

Each Tuesday and Friday (except legal holidays) three frequencies are transmitted as follows: noon to 1 P.M., Eastern Standard Time, 15,000 kc/s; 1:15 to 2:15 P.M., 10,000 kc/s; 2:30 to 3:30 P.M., 5,000 kc/s.

The emissions on 5000 kc/s are particularly useful at distances within a few hundred miles from Washington, those on 10,000 kc/s are useful for the rest of the United States, and those on 15,000 kc/s are useful in the United States and other parts of the world as well.

The emissions consist mainly of continuous, unkeyed carrier frequency, giving a continuous whistle in the phones when received with an oscillating receiving set. For the first five minutes the general call (CQ de WWV) and the announcement of the frequency are transmitted. The frequency and the call letters of the station (WWV) are given every ten minutes thereafter. The accuracy of the frequencies emitted is at all times better than a part in five million.

### Part 1. Checking Standard Oscillators.

Method of Measurement.— While the standard frequency emissions may be used for many standardization purposes, the most common use is to determine accurately the frequency of a piezo oscillator. The apparatus necessary is (1) the piezo oscillator, (2) a continuously variable radio-frequency generator which is approximately calibrated, (3) a variable audio-frequency generator, and (4) a radio receiving set. A frequency meter of resonance type is also useful but is not essential.

The fundamental frequency of a piezo oscillator is fixed by the dimensions of the quartz plate used. The vacuum-tube circuit arrangement in which the quartz plate is connected gives numerous harmonics for each fundamental frequency. The radio generator, which is continuously variable, can be adjusted to any frequency, and likewise gives a series of harmonics for each fundamental frequency to which it is adjusted. If the frequency of the radio generator is varied over a wide range, beat notes are produced at a number of settings of the generator by the interaction of various harmonics of the fundamental frequency of the piezo oscillator with a harmonic of the fundamental frequency of the generator. The beat notes may be heard in a pair of telephones suitably connected to the generator or to the piezo oscillator. Any frequency present in the piezo oscillator can beat with a corresponding frequency present in the radio generator, which makes it possible to set the generator at a number of frequencies which have a simple relation to the fundamental frequency of the piezo oscillator. Providing the harmonic relationship is known, measurements can be made at a great number of frequencies in terms of a single standard frequency.

If  $f$  is the fundamental frequency of the piezo oscillator which is being used and  $F$  the fundamental frequency of the auxiliary generator which gives zero beat, then

$$af = bF$$

where  $a$  and  $b$  are integers (1, 2, 3, 4, etc.).

The procedure is simplest when the ratio of the received radio frequency to the nominal frequency of the piezo oscillator to be standardized is a fairly small integer, less than 100. For instance, secondary standards whose fundamental frequencies are 50, 100, 200, 500, or 1000 kc/s can be measured very simply in terms of the emissions, and these secondary standards may be advantageously used in turn to calibrate other apparatus. It is, however, possible to use the emissions to establish accurately any desired frequency.

Examples of Measurement Method.— Suppose it is required to measure the frequency of a piezo oscillator, the approximate frequency of which is 700 kc/s, in terms of the 5,000-kc standard frequency emissions.

If the radio generator is set at 100 kc/s, the 50th harmonic (5000 kc/s) will beat with the 5000-kc emission, and the 7th harmonic (700 kc/s) will beat with the fundamental of the piezo oscillator.

The 5000-kc standard frequency emission is received first and identified with the receiving set in the generating condition. The radio generator is then turned on and adjusted to near 100 kc/s. This should give a beat note with the frequency generated by the receiving set. The regeneration of the receiving set is then reduced until the set just stops generating. A beat note should then be heard which will in general be of less intensity than that previously heard. This is the beat between the 50th harmonic of the radio generator and the frequency of the incoming wave. This beat note should be reduced to zero frequency by adjusting the radio generator. For most precise work, this adjustment should be made by using a beat-frequency indicator or other means of indicating exact zero beat. A simpler and equally accurate substitute is to bring in a tuning fork as described below. However, for a simple discussion of the steps involved in the measurement, it will be assumed that an accurate zero-beat setting is obtained.

The radio generator is therefore precisely adjusted so that it has a frequency of 100 kc/s. Without changing its adjustment, couple the piezo oscillator to it loosely. A beat note should be heard in the telephones in the output of the piezo oscillator unless the frequency given by the piezo oscillator is an exact

multiple of 100 kc/s. Suppose, for example, it is 700.520 kc/s. In this case a beat of 520 cycles per second will be heard. To determine the value of this note, the audio generator must be used.

The frequency of the beat note and the frequency of the audio generator may be compared by using single phone units from each source and rapidly interchanging them at the ear. If sufficient intensity is available from the two sources then the two audio frequencies will combine and beats may be heard by the ear when the audio generator is closely adjusted. For exact zero beat the frequency of the adjustable audio generator gives the difference in frequency between the 7th harmonic (700 kc/s) of the generator adjusted to 100 kc/s and the fundamental of the piezo oscillator.

Fig. 1 gives a diagrammatic representation of the frequencies used. It is necessary to determine whether the piezo oscillator frequency is higher or lower than 700 kc/s. This can be done by varying the frequency of the radio generator. If increasing the frequency of this generator results in decreasing the beat note, then the piezo oscillator frequency is higher than the reference frequency, that is, the audio frequency is to be added to 700 kc/s. If the reverse is true, then the audio frequency is to be subtracted.

Use of Audio-Frequency Note in Measurement.— A change in the method described above which does not require a beat indicator, is to adjust the radio generator to have a known frequency difference with the incoming wave by means of matching with that of a tuning fork of known frequency such as 1000 c/s. This method is more complicated in calculation because a record must be made of four factors, (1) as to whether the radio generator was adjusted higher or lower than zero beat, (2) the frequency difference, (3) the harmonic relation between the standard signal and the radio generator, and (4) the harmonic relation between the radio generator and the piezo oscillator. The harmonic relations, however, come in to any method of measurement of this kind. The measurements involving the use of the tuning fork for adjusting the generator to give a beat note 1,000 cycles below the 5,000-kc signal would be made as follows, and are shown diagrammatically in Fig. 2. Set generator from approximate zero beat at 100 kc/s to 99.98 kc/s. The 50th harmonic is  $99.98 \times 50 = 4,999.0$  kc/s (beats with 5,000 kc/s in receiver which is not oscillating and gives a 1000-cycle note). The 7th harmonic of the generator ( $99.98 \times 7 = 699.86$  kc/s) may now be heard beating in the telephones of the piezo oscillator which is known to be approximately 700 kc/s. If this value were exactly 700, a note of  $700.000 - 699.860$  kc/s or 140 c/s would be heard. However,

the beat note produced is matched with a corresponding note from the audio generator. If the piezo oscillator had the frequency of 700.520 kc/s as assumed previously, the audio-frequency note measured would have been  $700.520 - 699.860 = 0.660$  kc/s or 660 c/s.

Whether to add or subtract the audio-frequency note of 660 c/s to the known frequency of 699.860 kc/s would be decided as follows when the radio-frequency generator was set lower than the standard frequency signal. If lowering the frequency of the radio generator increases the beat note (660 c/s in this case), add the beat note frequency, or if increasing the frequency of the radio generator decreases the beat note, add the beat note frequency.

Fig. 1

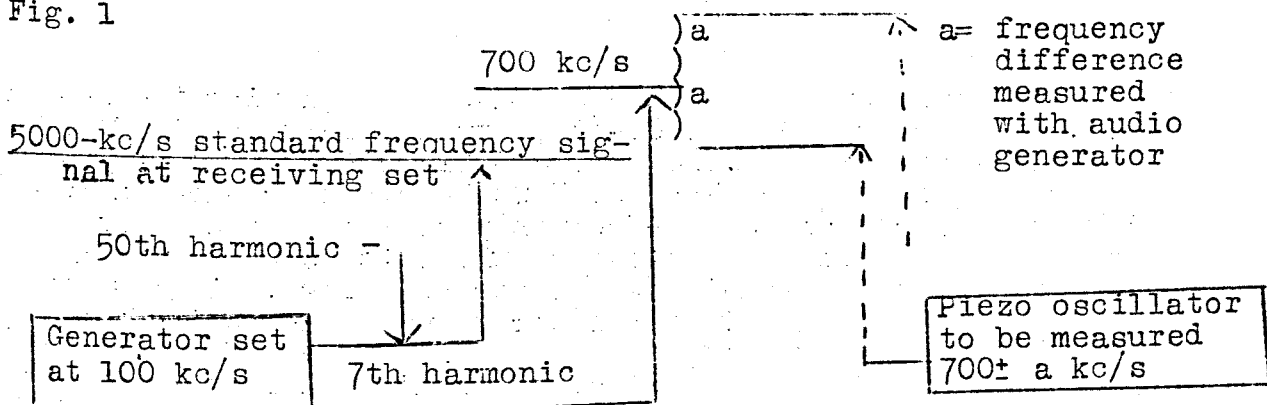

Fig. 2

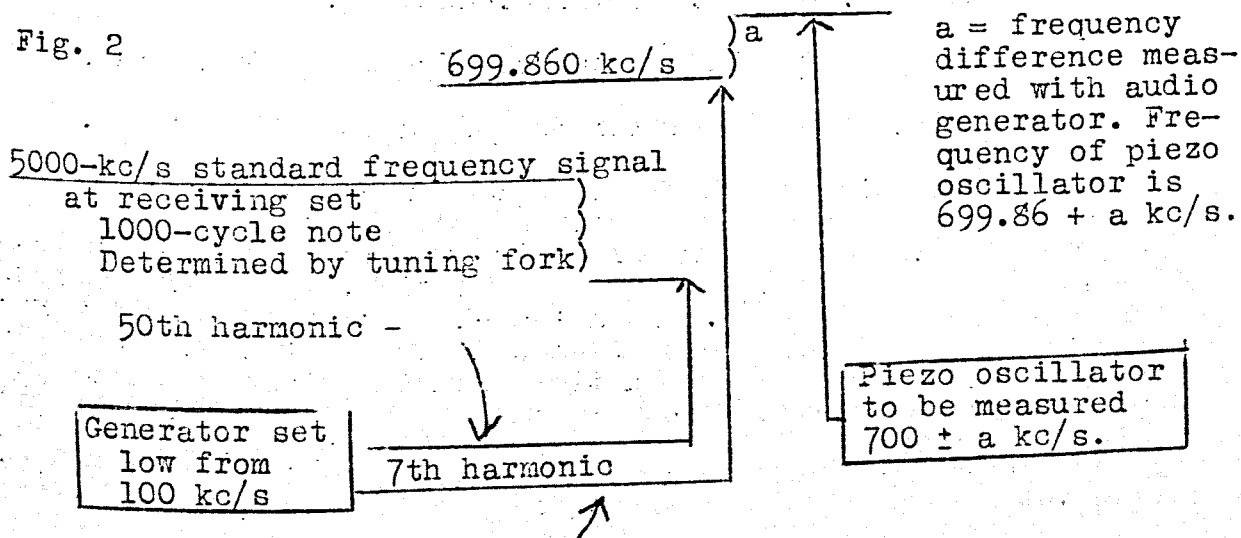
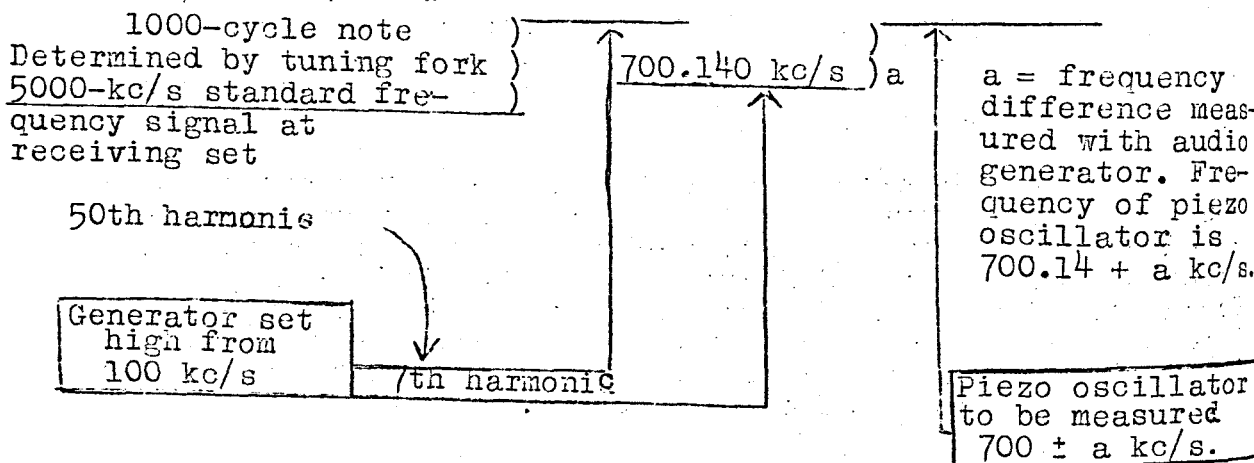

Fig. 3.



The measurement could also be made by adjusting the generator to 100.020 kc/s using the 1000-cycle tuning fork, as in Fig. 3. The 50th harmonic is  $100.020 \times 50 = 5001$  kc/s which beats with the standard frequency signal of 5000 kc/s and produces a 1000-cycle note. A certain audio-frequency note is produced in the telephones of the piezo oscillator, which is matched with a similar note from the audio oscillator as before. If lowering the frequency of the radio generator reduces the audio-frequency note heard, subtract it from the known frequency of 700.140 kc/s, or if increasing the frequency of the radio generator increases the audio note, subtract it. The audio-frequency note heard with a piezo oscillator having the assumed frequency would be 380 c/s, hence  $700.140 + 0.380 = 700.520$  kc/s.

## Part 2. Checking Broadcast Frequency Standards.

### A. Integral Sub-multiples of Emission Frequency.

The frequencies which are integral sub-multiples of the emission frequency are most easily measured. For the emission frequency of 5000 kc/s there are only two broadcast frequencies, 1000 and 1250 kc/s, which bear this relation. The fifth harmonic of 1000 kc/s is 5000 kc/s. If a 1000-kc/s oscillator, whether a transmitting set or frequency standard, is coupled to a radio receiver tuned to 5000 kc/s at a time when the standard signal is being received, a heterodyne note will be produced which is equal to the frequency difference between the 5th harmonic of the 1000-kc/s oscillator and the standard signal. Assuming that the nominal value of the 1000-kc/s oscillator is known, all that remains

in order to measure the frequency accurately, is to determine the frequency of the beat note and whether the frequency is higher or lower than the standard signal. This is done when the radio receiver is not in the generating condition. The most convenient method, if the beat note is in the audible range, is to match it with a known audio frequency produced by a calibrated audio oscillator. The direction of the deviation is most easily determined by making a slight change of known direction in the unknown frequency. If an increase in the unknown frequency increases the frequency of the beat note the unknown frequency is high. If an increase in the unknown frequency decreases the frequency of the beat note, the unknown frequency is low. Conversely, if a decrease in the unknown frequency increases the frequency of the beat note the unknown frequency is low, and if a decrease in the unknown frequency decreases the frequency of the beat note, the unknown frequency is high. If the audio frequency to be measured is between 5 and 200 c/s, the audio-frequency arrangement described in a previous Bureau publication by N. P. Case can be used with a very high degree of accuracy. If the audio frequency is still lower and goes below the range of the audio-frequency amplifier, it is necessary to provide a carrier for this audio-frequency note. This is done by making the radio receiver generate and adjusting the resulting beat note so that it is approximately 1000 c/s. A fluctuation in the amplitude of this 1000-cycle note, which has a frequency equal to the frequency difference between the two radio frequencies, will then be heard. If it is only desired to readjust the unknown frequency to agreement with the standard signal, it is a simple matter to adjust to zero beat. The same method can be used for a frequency of 1250 kc/s. Precaution must be taken to make it possible to combine the signals with approximately equal intensity. Some difficulty in this respect may be expected if measurements are made when the transmitter is operating unless the harmonics are very completely suppressed.

A station frequency monitor which utilizes a piezo oscillator having a frequency of 1000 or 1250 kc/s can be measured or adjusted to frequency in a similar manner. If the radio transmitter is operating, the measurement can be made indirectly in terms of the transmitter in the following manner. Measure the frequency of the radio transmitter in terms of the 5000-kc signal and simultaneously read the frequency as indicated by the frequency deviation meter on the monitor. The two frequencies should agree. If they do not, adjust the frequency monitor until the deviation meter indicates the correct frequency deviation. It may be desirable to measure the frequency monitor directly against the standard signal at a time when the radio transmitter is not operating.

See Reference (32), Part 3.

If the frequency monitor is of the type which is adjusted to exactly 1000 or 1250 kc/s, the measurement can be made the same as in the case of the radio transmitter. However, if the monitor is set high or low by 500 or 1000 c/s, it will be necessary to make use of an audio oscillator to determine the value of the audio beat frequency. In the case of a monitor which has a frequency of 999.500 or 1000.500 kc/s, the beat note to be measured would be 2500 c/s. As five cycles variation in the beat note is only 1 part in  $10^6$ , any audio oscillator which would be constant to 5 or 10 c/s would be adequate. In the case of a monitor which has a frequency of 999.000 or 1001.000 kc/s, a 5000-cycle note would be produced. Similarly for 1250 kc/s, audio-frequency beat notes of 2000 and 4000 c/s would have to be measured. The general relation is that the audio-frequency note produced by heterodyning the monitor frequency and the 5000-kc standard signal is equal to the product of the number of cycles the monitor is set high or low and the ratio of 5000 to the nominal value of the monitor.

The same principles may be followed for the 10,000 and 15,000-kc emissions.

### B. Measurements with Auxiliary Generator for Frequency Multiples of 50.

Measurements of any of these frequencies require the use of an auxiliary generator in addition to the high-frequency receiver. The auxiliary generator may be a piezo oscillator or it may be a manually controlled oscillator. If a piezo oscillator of the desired frequency is available, it is desirable to use one. In this case a distorting amplifier is necessary in order to bring out the harmonics so that the beat against the standard signal can be easily heard. This piezo oscillator should be provided with a vernier frequency adjustment<sup>2/</sup> so that it can be readily adjusted to agreement with the 5000-kc standard in the manner previously described. After this is done the monitor or radio transmitter can be measured in terms of harmonics of the auxiliary generator. If a manually controlled generator is used, the  $\frac{L}{C}$  ratio must be low so that the frequency can be easily adjusted to zero beat with the standard frequency, and readily held on that frequency.

There are two main factors which determine the frequency to which the auxiliary generator should be adjusted. The first is that its frequency must have an integral relationship with the standard frequency and the frequency to be measured. The second is that the harmonic which is heterodyned with the standard frequency must be of sufficient intensity to produce a beat note

<sup>2/</sup> See references (21) and (75), Part 3.



which is easily recognized. Taking both factors into account the best result is attained if the frequency of the auxiliary generator is the highest common factor of the standard frequency and the frequency to be measured. There is one other consideration in the case of a manually controlled auxiliary generator and that is, the lower its frequency, the less trouble is experienced in holding it at zero beat against the standard frequency. The following table indicates the broadcast frequencies which can be measured in terms of the 5000-kc standard frequency emission by means of a high-frequency radio receiver and an auxiliary generator. It will be understood that the table gives all broadcast frequencies which are multiples of 50, but does not indicate more than one generator frequency for these frequencies except for 1000 and 1500 kc/s.

Broadcast Frequencies Measurable with Auxiliary Generator

<u>Frequency of Auxiliary Generator in kc/s.</u>			
<u>500</u>	<u>200</u>	<u>100</u>	<u>50</u>
1000	600	700	550
1500	800	900	650
	1000	1100	750
	1200	1300	850
	1400	1500	950
			1050
			1150
			1250
			1350
			1450

As an example of this method of measurement, assume the frequency of the radio transmitter to be 1150 kc/s. The radio receiver, in the generating condition, is tuned until the 5000-kc standard frequency signal is heard. The auxiliary generator, set on approximately 50 kc/s, is then turned on and the frequency varied until a second audio frequency is heard on the output of the high-frequency receiver. If the radio receiver is then adjusted so that it does not generate, the auxiliary generator can be set to zero beat with the standard frequency signal. If the radio receiver is again made to generate, the auxiliary generator can be easily set to agreement with the standard frequency signal as previously explained. The rough adjustment to zero beat must be made when the radio receiver is in the non-generating condition, otherwise there is danger of setting to zero beat between the two audio frequencies or harmonics of the audio frequencies. If a

piezo oscillator is used, this precaution is unnecessary. A detector-amplifier is set up so as to receive portions of the outputs of the auxiliary generator and the 1150-kc radio transmitter, Fig. 4. The output of the amplifier will give the audio beat-frequency between the 23d harmonic of the auxiliary generator and the 1150 kc/s of the radio transmitter. If this audio frequency is reduced to zero as indicated on a visual beat indicator the transmitter frequency will be in exact agreement with the standard frequency signal. One person can make this adjustment, as an aural indication may be used for the auxiliary generator and a visual one for the transmitter adjustment.

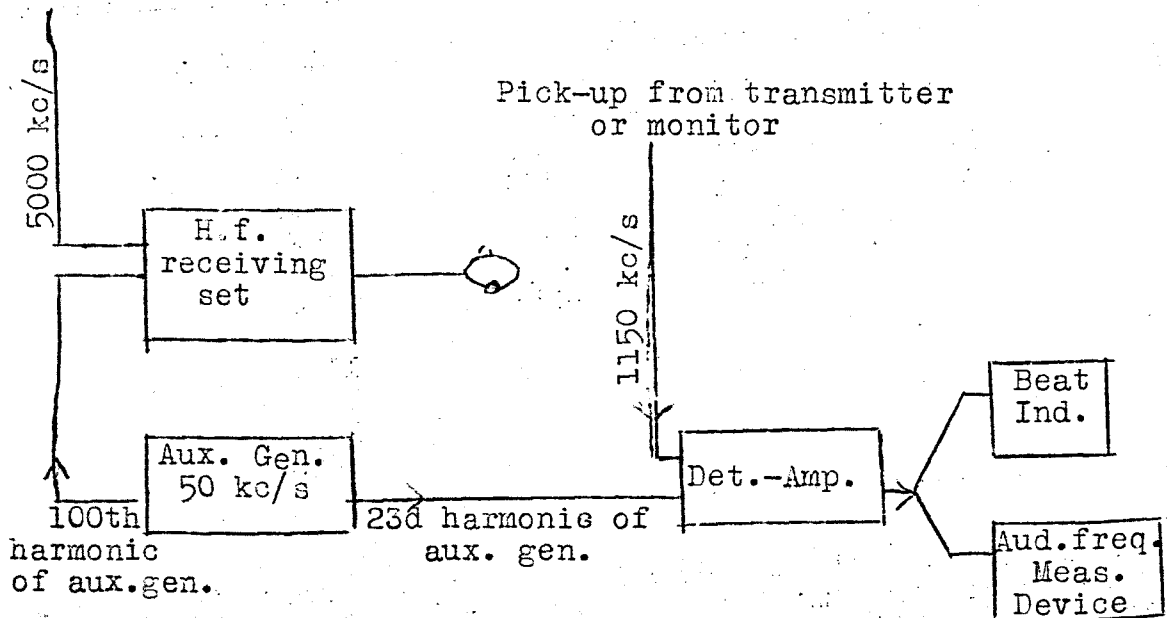

Fig. 4.

If a piezo oscillator is used as the auxiliary generator, it need only be checked against the standard frequency signal at intervals.

C. Measurement of Any Broadcast Frequency.

The methods of measurement given in the preceding paragraphs are applicable to twenty of the frequencies in the broadcast band. The highest common factor of 5000 and the remaining broadcast frequencies is 10. The frequency of the auxiliary generator must therefore be 10 kc/s if the other broadcast frequencies are to be checked readily in terms of the 5000-kc emissions. The beat note between the 500th harmonic of the 10-kc generator and the 5000-kc emission would not be loud enough to be heard distinctly. The simplest solution, therefore, is to set the auxiliary generator on 100 kc/s and let it control a 10-kc multivibrator. The beat against the standard frequency signal could then be heard easily and the harmonics of the 10 kc/s would heterodyne equally well with frequencies in the broadcast band. It is evident that with this equipment all assigned frequencies in the broadcast band can be checked against the 5000-kc standard frequency signal, Figure 5.

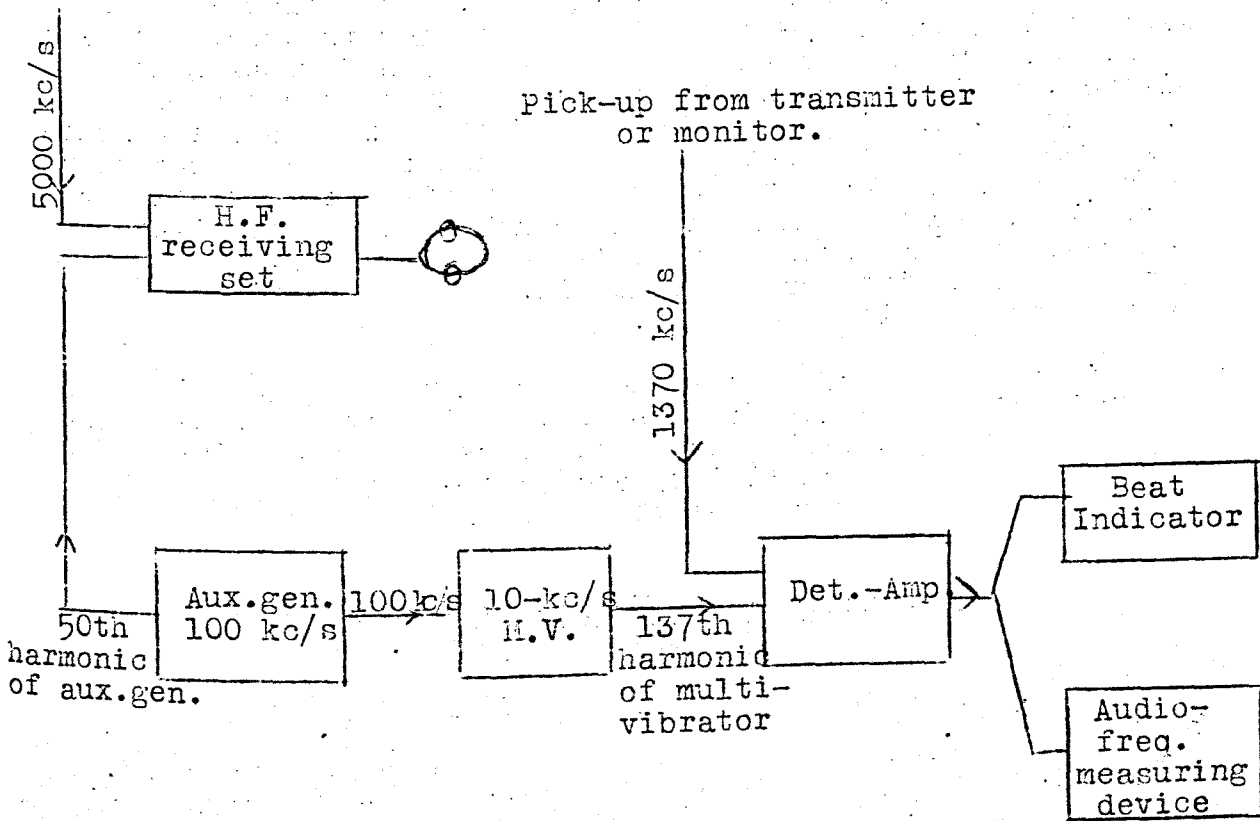

Fig. 5.

There are some cases in which a frequency can be measured by more than one of the methods indicated. The question arises as to the advantages and disadvantages of the various possibilities or as to how existing equipment might be brought into use. The first method is applicable to only two frequencies. It provides the most accurate check for frequencies which are very near the harmonic value. For monitors, however, which are set high or low by 500 or 1000 c/s, the audio frequency which must be measured is so high that it is very difficult to determine its value. This method is further handicapped by the fact that if the measurements are made in the transmitting station when the power amplifier is operating, the harmonic which is picked up on the receiver may be so strong that it will block the receiver. If that is the case it would be necessary to locate the receiver at some distance from the transmitter and use a line between transmitter and receiver.

The second method requires an auxiliary generator and detector-amplifier in addition to the equipment used in the first method. A small error may be introduced in this method in the adjustment of the auxiliary generator. If a piezo oscillator is used this error is negligible. The error is much greater if a manually-controlled oscillator is used. In either case, however, it should not be more than a few parts in a million. This method is applicable to 20 of the broadcast frequencies, and is much more satisfactory for checking monitors which are set off-frequency because the audio frequency to be measured equals the amount the monitor is set high or low. If a harmonic amplifier is coupled to the auxiliary generator so that sufficient voltage is provided, the measurement of the monitor can be read directly on the visual indicator provided with that unit.

It is necessary to use the third method in checking the remaining 76 broadcast frequencies. This method requires a high-frequency receiving set, auxiliary generator, 10-kc multi-vibrator, detector-amplifier, and audio-frequency measuring equipment. The accuracy of this method is the same as of the second method.

### Part 3. Bibliography on Frequency Measurements and Associated Equipment.

Note.— The publications in the following list are in chronological order. Except where noted, they are not issued by, nor are they available from, the National Bureau of Standards. These publications can be consulted in public libraries which maintain files of periodicals, or copies may be secured from the publishers at the addresses given below.

- Annalen der Physik. J. Ambrosius Barth, Leipzig, Germany.
- Bell Laboratories Record. 463 West Street, New York, N.Y.
- Bell System Technical Journal. 195 Broadway, New York, N.Y.
- Experimental Wireless & The Wireless Engineer. See The  
Wireless Engineer and Experimental Wireless.
- General Radio Experimenter. 30 State Street, Cambridge A, Mass.
- Hochfrequenztechnik und Elektroakustik. Akademische Ver-  
lagsgesellschaft MBH, Leipzig, Germany.
- Journal of the Optical Society of America (formerly Journal  
Optical Society of America & Review of Scientific Instruments).
- American Institute of Physics, 11 E. 38th St., New York, N.Y.
- Marconi Review, Marconi's Wireless Telegraph Co., Ltd., Electra  
House, Victoria Embankment, London, W.C.2, England.
- Physics. American Institute of Physics, 11 E. 38th St.,  
New York, N.Y.
- Physical Review, American Institute of Physics, 11 E. 38th St.,  
New York, N.Y.
- Physikalische Zeitschrift. S. Hirzel, Leipzig, Germany.
- Proceedings American Academy of Arts & Sciences. Library of  
the American Academy of Arts & Sciences, 28 Newbury St.,  
Boston, Mass.
- Proceedings of the Institute of Radio Engineers. 330 West 42nd  
St., New York, N.Y.
- Proceedings of the Royal Society. Harrison & Sons, Ltd., 44-47  
St. Martin's Lane, London, WC2, England.
- QST. American Radio Relay League, W. Hartford, Conn.
- Radio Engineering. Bryant Publishing Co., 19 E. 47th St.,  
New York, N.Y.
- Report of Radio Research in Japan. National Research Council  
of Japan, Tokyo, Japan.
- The Electric Journal. 530 Fernando St., Pittsburgh, Pa.
- The Journal of the Institution of Electrical Engineers,  
Savoy Place, Victoria Embankment, London WC2, England.
- The Proceedings of the Physical Society. 1 Lowther Gardens,  
Exhibition Road, London, SW7, England.
- The Review of Scientific Instruments. American Institute of  
Physics, 11 E. 38th St., New York, N.Y.
- The Wireless Engineer and Experimental Wireless. Iliffe & Sons,  
Ltd., Dorset House, Stamford St., London, SE1, England.

The papers which have been issued by the National Bureau of Standards can be purchased from the Superintendent of Documents, Government Printing Office, Washington, D.C., at the prices which are indicated after the references. The prices quoted are for delivery to addresses in the United States and its possessions, and to Canada, Cuba, Mexico, Newfoundland, the Philippines, and the Republic of Panama. For delivery to countries other than those, remittance should be increased by one-third of the total cost of publications to cover postage.

Remittances should be made payable to the "Superintendent of Documents, Government Printing Office, Washington, D.C." and sent to him with the order.

Serial letters and numbers are used to designate Bureau publications. S, "Scientific Paper", is used for reprints from the "Scientific Papers of the Bureau of Standards" (Sci.Pap.BS). This series was superseded by the "Bureau of Standards Journal of Research" in 1928. RP, "Research Paper", designates reprints of articles appearing in the "Bureau of Standards Journal of Research" (BSJ, Research) and the "Journal of Research of the National Bureau of Standards" (J.Research NBS), the latter being the title of this periodical since July, 1934 (volume 13, number 1).

In each reference below, unless otherwise indicated, the first number (underscored) is the volume of the periodical; the numbers following indicate pages and the year of publication. Names of periodicals here abbreviated can be found in full in the list of addresses above.

1. The piezoelectric resonator. W. G. Cady. Proc.I.R.E., 10, 83-114, April 1922.
2. Piezoelectric crystal resonators and crystal oscillators applied to the precision calibration of wavemeters. G. W. Pierce. Proc. Am. Acad. of Arts & Sci., 59, 81-106, Oct. 1923.
3. A method of measuring very short radio wave lengths and their use in frequency standardization. F. W. Dunmore and F. H. Engel. Proc. I. R. E., 11, 467-478, Oct. 1923.
4. Piezoelectric standards of high frequency. W. G. Cady. Jour. Optical Soc. Am., 10, 475, April 1925.
5. A method of calibrating a low frequency generator with a one frequency source. S. Harris. Proc.I.R.E., 14, 213-216, April 1926.
- \*6. Establishment of radio standards of frequency by the use of a harmonic amplifier. C. B. Jolliffe and Grace Hazen. Sci. Papers, Bureau of Standards, 21, 179-189, 1926. (S530, 10/4).

\*Obtainable from Superintendent of Documents, Government Printing Office, Washington, D.C., at price stated. Designate publication by the letter and number appearing just before price.

7. Uses and possibilities of piezoelectric oscillators. A. Hund. Proc. I.R.E., 14, 447-469, August 1926.
8. Piezoelectric quartz resonator and equivalent electric circuit. D. W. Dye. Proc. Physical Soc., 38, 399-457, discussion pp. 457-458, August 1926.
9. Quartz crystal calibrators. A. Crossley. QST, 11, pp. 23-27 of March, 1927.
10. Frequency checking station at Mare Island. G. T. Royden. Proc. I.R.E., 15, 313-318, April 1927.
11. The exact and precise measurement of wave length in radio transmitting stations. R. Braillard and E. Divoire. Exp. Wireless & W. Eng., 4, 322-330, June 1927.
12. Universal frequency standardization from a single frequency standard. J. K. Clapp. Jour. Optical Soc. Am. and Rev. of Sci. Instruments, 15, 25-47, July 1927.
13. Radio-frequency standards. R. C. Hitchcock. Electric Journal, 24, 430-438, September 1927.
14. Mounting quartz plate oscillator crystals. R. C. Hitchcock. Proc. I.R.E., 15, 902-913, November 1927.
15. Precision determination of frequency. J. W. Horton and W. A. Marrison. Proc. I.R.E., 16, 137-154, February 1928.
16. Bibliography on piezoelectricity. W. G. Cady. Proc. I.R.E., 16, 521-535, April 1928.
17. A convenient method for referring secondary frequency standards to a standard time interval. L. M. Hull and J. K. Clapp. Proc. I.R.E., 17, 252-271, February 1929.
18. A system for frequency measurements based on a single frequency. E. L. Hall. Proc. I.R.E., 17, 272-282, February, 1929.
19. Measurement of the frequencies of distant radio transmitting stations. G. Pession and T. Corio. Proc. I.R.E., 17, 734-744, April 1929.
20. A high precision standard of frequency. W. A. Marrison. Proc. I.R.E., 17, 1103-1122, July 1929; Bell System Tech. Jour., 8, 493-514, July 1929.

21. The routine measurement of the operating frequencies of broadcast stations. H. L. Bogardus and C. T. Manning. Proc. I.R.E., 17, 1225-1239, July 1929.
22. Measurement of wave lengths of broadcasting stations. R. Brailard and E. Divoire. Exp. Wireless and W. Eng., 6, 412-421, August 1929.
23. Observations on modes of vibrations and temperature coefficients of quartz crystal plates. F. R. Lack. Proc. I.R.E., 17, 1123-1141, July 1929; Bell System Tech. Jour., 8, 515-535, July 1929.
24. An electromagnetic monochord for the measurement of audio frequencies. J. W. Owen-Harries. Proc. I.R.E., 17, 1316-1321, August 1929.
25. Measurement of frequency. S. Jimbo. Proc. I.R.E., 17, 2011-2033, November 1929.
26. The dimensions of low frequency quartz oscillators. R. C. Hitchcock. Rev. of Sci. Instruments, 1, 13, January, 1930.
27. Frequency standardization. J. K. Clapp and J. D. Crawford. QST, 14, pp.9-15 of March 1930.
- \*28. Method and apparatus used in testing piezo oscillators for broadcasting stations. E. L. Hall. Bureau of Standards Jour. Research, 4, 115-130, January 1930, (RP135, 10¢). Proc. I.R.E., 18, 490-509, March 1930.
- \*29. Design of a portable temperature-controlled piezo oscillator. V. E. Heaton and W. H. Brattain. Bureau of Standards Jour. Research, 4, 345-350, March 1930, (RP153, 5¢). Proc. I.R.E., 18, 1239-1246, July 1930.
30. A constant frequency oscillator. C. W. Miller and H. L. Andrews. Rev. of Sci. Instruments, 1, 267-276, May 1930.
31. The establishment of the Japanese radio-frequency standard. Y. Namba. Proc. I.R.E., 18, 1017-1027, June 1930.

---

\* Obtainable from Superintendent of Documents, Government Printing Office, Washington, D.C., at price stated. Designate publication by the letter and number appearing just before price.



- \*32. A precise and rapid method of measuring frequencies from five to two hundred cycles per second. N. P. Case. Bureau of Standards Jour. Research, 5, 237-242, August 1930, (RP195, 5<sup>a</sup>). Proc. I.R.E., 18, 1586-1592, Sept. 1930.
33. Interpolation methods for use with harmonic frequency standards. J. K. Clapp. Proc. I.R.E., 18, 1575-1585, Sept. 1930.
- \*34. Accurate method of measuring transmitted wave frequencies at 5000 and 20,000 kilocycles per second. E. L. Hall. Bureau of Standards Jour. Research, 5, 647-652, Sept. 1930, (RP220, 5<sup>a</sup>). Proc. I.R.E., 19, 35-41, Jan. 1931.
35. Characteristics of piezoelectric quartz oscillators. I. Koga. Proc. I.R.E., 17, 1935-1959, Nov. 1930.
36. Frequency division. J. Groszkowski. Proc. I.R.E., 18, 1960-1970, Nov. 1930.
37. Temperature control for frequency standards. J. K. Clapp. Proc. I.R.E., 18, 2003-2010, Dec. 1930.
38. Some methods of measuring the frequency of short waves. H. Mögel. Proc. I.R.E., 19, 193-213, Feb. 1931.
39. Monitoring the operation of short wave transmitters. H. Mögel. Proc. I.R.E., 19, 214-232, Feb. 1931.
40. Measurements of temperature coefficient and pressure coefficient of quartz crystal oscillators. S. Brown and S. Harris. Rev. of Sci. Instruments, 2, 180-183, March 1931.
41. Direct-reading frequency meter. F. Guarnaschelli and F. Vecchiacchi. Proc. I.R.E., 19, 659-663, April 1931.
42. A device for the precise measurement of high frequencies. F. A. Polkinghorn and A. A. Roetken. Proc. I.R.E., 19, 937-948, June 1931.
43. Measuring frequency characteristics with the photo-audio generator. W. Schaffer and G. Lubszynski. Proc. I.R.E., 19, 1242-1251, July 1931.

---

\* Obtainable from Superintendent of Documents, Government Printing Office, Washington, D.C., at prices stated. Designate publication by the letter and number appearing just before price.

44. A thermionic type frequency meter for use up to 15 kilocycles. F. T. McNamara. Proc. I.R.E., 19, 1384-1390, August 1931.
- \*45. Quartz plate mountings and temperature control for piezo oscillators. V. E. Heaton and E. G. Lapham. Bureau of Standards Jour. Research, 7, 683-690, Oct. 1931, (RP366, 10¢). Proc. I.R.E., 20, 261-271, Feb. 1932. Discussion; Proc. I.R.E., 20, 1064, Feb. 1932.
- \*46. An improved audio-frequency generator. E. G. Lapham. Bureau of Standards Jour. Research, 7, 691-695, Oct. 1931, (RP367, 10¢). Proc. I.R.E., 20, 272-279, Feb. 1932.
47. The adjustment of the multivibrator for frequency division. J. V. Andrew. Proc. I.R.E., 19, 1911-1917, Nov. 1931.
48. A piezoelectric oscillator of improved stability. J. K. Clapp. General Radio Exp., 6, pp.1-16 of Dec., 1931.
49. Quartz resonators and oscillators. P. Vigoureux. 1931. (Obtainable from British Library of Information, French Bldgs., East 45th St., New York, N.Y., 7 shillings, 6 pence).
50. A frequency indicator for transmitters. General Radio Exp., 6, pp.5-7 of Jan., 1932.
51. Notes on the frequency stability of quartz plates. L. B. Hallman, Jr. Radio Eng., 12, pp.15-19 of Feb., 1932.
52. Quartz crystal resonators. W. A. Harrison. Bell Laboratories Record, 10, 194-199, Feb. 1932.
53. Silvering electrodes on quartz crystals. G. B. Parsons. QST, 16, p.20 of March, 1932.
54. Recent developments in precision frequency control. D. E. Replogle. Radio Eng., 12, pp.29-32 of April, 1932.
55. An audio oscillator of the dynatron type. D. Hale. Rev. of Sci. Instruments, 3, 230-234, May 1932.

\* Obtainable from Superintendent of Documents, Government Printing Office, Washington, D.C., at price stated. Designate publication by the letter and number appearing just before price.

56. Application of quartz plates to radio transmitters. O. M. Hovgaard. Proc. I.R.E., 20, 767-782, May 1932.
57. The vibrations of quartz plates. R. C. Colwell. Proc. I.R.E., 20, 808-812, May 1932.
58. Experimental study of parallel-cut piezoelectric quartz plates. G. W. Fox and W. G. Hutton. Physics, 2, 443-447, June 1932.
59. The precision frequency measuring system of R.C.A. Communications Inc. H. O. Peterson and A. M. Bratten. Proc. I.R.E., 20, 941-956, June 1932.
60. The design of temperature-control apparatus for piezo oscillators. V. J. Andrew. Rev. of Sci. Instruments, 3, 341-351, July 1932.
61. A low-frequency oscillator. J. M. Hudack. Bell Laboratories Record, 10, 378-380, July 1932.
62. The quartz oscillator. T. D. Parkin. Marconi Rev., #37, pp.1-10 of July-Aug., 1932.
63. A new beat-frequency oscillator. S. M. Bagno. Radio Eng., 12, pp.14-15 of Sept., 1932.
64. The wavemeter yields. C. E. Worthen. General Radio Exp., 7, pp.1-4 of Oct., 1932.
65. A precision tuning fork frequency standard. E. Norrman. Proc. I.R.E., 20, 1715-1731, Nov. 1932.
66. A piezoelectric clock for time and frequency measurements of great accuracy. A. Scheibe and U. Adelsberger. Physikalische Zeitschrift, 33, 835-841, Nov. 1932.
67. On the piezoelectric properties of tourmaline. G. W. Fox and M. Underwood. Physics, 4, 10-13, Jan. 1933.
68. Frequency measurements at radio frequencies. Bulletin 10. General Radio Co., Cambridge, Mass. Jan. 1933.
69. A combination monitor and frequency meter for the amateur. General Radio Exp., 7, pp.5-7 of Jan., 1933.
70. A heterodyne oscillator of wide frequency range. J. G. Kreer, Jr. Bell Laboratories Record, 11, 137-139, Jan. 1933.

71. A frequency monitoring unit for broadcast stations. R. E. Coram. Radio Eng., 13, pp.18-19 of Feb., 1933.
72. Mounting quartz plates. F. R. Lack. Bell Laboratories Record, 11, 200-204, March 1933.
73. On tourmaline oscillators. S. Matsumura and S. Ishikawa. Report of Radio Research in Japan, 3, No.1, 1-5, June 1933.
74. A more stable crystal oscillator of high harmonic output. QST, 17, pp.30-32 of June, 1933.
- \*75. A 200-kilocycle piezo oscillator. E. G. Lapham. Bureau of Standards Jour. Research, 11, 59-64, July 1933, (RP576, 5¢).
76. A simplified frequency dividing circuit. V. J. Andrew. Proc. I.R.E., 21, 982-983, July 1933.
77. Modes of vibration of piezo-electric crystals. N. H. Williams. Proc. I.R.E., 21, 990-995, July 1933.
78. A precision method of absolute frequency measurement. H. Kono. Report of Radio Research in Japan, 3, No. 2, 127-136, Sept. 1933.
79. Frequency and drift of quartz frequency standards. A. Scheibe and U. Adelsberger. Annalen der Physik, 18, 1-25, Sept. 1933.
80. Automatic temperature compensation for the frequency meter. G. F. Lampkin. QST, 17, pp.16-19 of Oct., 1933.
81. The valve maintained tuning fork as a primary standard of frequency. D. W. Bye and L. Essen. Proc. Royal Soc. A143, 285-306, Jan. 1, 1934.
- \*82. Development of standard frequency transmitting sets. L. Mickey and A. D. Martin, Jr. Bureau of Standards Jour. Research, 12, 1-12, Jan. 1934, (RP630, 5¢).

---

\* Obtainable from Superintendent of Documents, Government Printing Office, Washington, D.C., at price stated. Designate publication by the letter and number appearing just before price.

83. The technical arrangements of the quartz controlled clocks of the Physikalisch-Technischen Reichsanstalt. A. Scheibe and U. Adelsberger. Hochfrequenztechnik und Elektroakustik, 43, 37-47, Feb. 1934.
84. The bandsetter. G. F. Lampkin. QST, 18, pp.35-37 of Feb., 1934.
85. The testing of frequency monitors for the Federal Radio Commission. W. D. George. Proc. I.R.E., 22, 449-456, April 1934.
86. The crystal control of transmitters. R. Bechmann. Wireless Eng. & Exp. W., 11, 249-253, May 1934.
87. Description of the quartz control of a transmitter at 1785 kilocycles per second. L. Essen. Jour. A.I.E.E., 74, 595-597, June 1934.
88. Primary frequency standard. J. G. Beard. Radio Eng., 14, pp.15-17 of June, 1934.
89. Some improvements in quartz crystal circuit elements. F. R. Lack, G. W. Willard and I. E. Fair. Bell System Tech. Jour., 13, 453-463, July 1934.
90. Piezoelectric stabilization of high frequencies. H. Osterberg and J. W. Cookson. Rev. of Sci. Instruments, 5, 281-286, Aug. 1934.
91. Notes on the measurement of radio frequencies. W. H. F. Griffiths. Wireless Eng. & Exp. W., 11, 524-532, Oct. 1934.
92. The piezoelectric properties of quartz and tourmaline. G. W. Fox and G. A. Fink. Physics, 5, 302-306, Oct. 1934.
93. Quartz crystal fundamentals. J. M. Wolfskill. QST, 18, pp.37-40 of Dec., 1934.
94. Cutting quartz crystal plates. I. H. Loucks. QST, 19, pp.36-38 of Jan., 1935.
95. Grinding and finishing quartz crystal plates. I. H. Loucks. QST, 19, pp.28, 74, 76, 78 of Feb., 1935.

- \*96. The National primary standard of radio frequency.  
E. L. Hall, V. E. Heaton and E. G. Lapham. Jour.  
Research of the N.B.S., 13, 85-98, Feb. 1935, (RP759).

Department of Commerce,  
Washington, D. C.

---

\*Obtainable from Superintendent of Documents, Government Printing Office, Washington, D. C., at price stated. Designate publication by the letter and number appearing just before price.