

RESEARCH PAPER RP946

*Part of Journal of Research of the National Bureau of Standards, Volume 17, [pp. 805-839]
December 1936*

THE VALUE OF GRAVITY AT WASHINGTON

By Paul R. Heyl and Guy S. Cook

ABSTRACT

An absolute determination of the value of gravity in the constant-temperature room in the second subbasement of the East Building of the National Bureau of Standards has given the value 98.08 cm/sec^2 . This determination was carried out with pendulums of fused silica, and special attention was directed to the flexure correction

CONTENTS

	Page
I. Introduction -----	805
1. Purpose of the work-----	805
2. Previous absolute determinations of gravity -----	806
3. Plan of the present determination-----	806
II. The observing room -----	807
III. The pendulum apparatus -----	807
1. The pendulums-----	807
2. The supporting apparatus and vacuum case-----	814
3. The knife-edges-----	816
IV. Measurement of length -----	816
1. The standard scale-----	816
2. The microscopes-----	818
3. The comparator -----	818
4. Methods employed -----	819
V. Measurement of time -----	821
1. The clock -----	821
2. The time-signal system -----	821
3. Method of observing-----	822
4. Corrections -----	823
(a) Clock rate -----	823
(b) Temperature -----	823
(c) Motion of the support -----	823
(d) Damping -----	824
(e) Residual air -----	825
(f) Compressibility of the pendulum-----	826
(g) Flexure of the pendulum-----	827
(h) Amplitude-----	828
(i) Imperfections of the knife-edge-----	828
VI. Results -----	831
VII. The Potsdam determination -----	838

THE VALUE OF GRAVITY AT WASHINGTON

I. INTRODUCTION

1. PURPOSE OF THE WORK

The work herein described was undertaken by the National Bureau standards at the request of the U. S. Coast and Geodetic Survey, in order to obtain by absolute measurement the value of gravity at the base station of the Survey in Washington. Prior to this work the value adopted by the Survey had rested upon relative comparisons with the absolute-gravity station at Potsdam, Germany. Several [806] such comparisons had given results for the Survey's old base station at 205 New Jersey Avenue SE., varying by as much as 9 parts in a million. In 1900 a direct connection of that station with Potsdam and other stations in Europe was made by G. R. Putnam. The value obtained for Washington was 980.112. More recently a connection was made with Ottawa, Canada, which had an independent connection with Potsdam, and the value obtained for Washington was 980.117. Again, when Dr. F. A. Vening Meinesz, of Holland, brought his gravity-at-sea apparatus to this country the value he found for Washington was 980.121. In view of these varying results it was felt that the Survey's adopted value of 980.112 was probably too small, and that an absolute determination at Washington should be undertaken.

During the progress of this work a new direct connection with Potsdam was made in 1933 by Lt. Brown of the Survey. His result, calculated in terms of the old station, which had then been abandoned by the Survey, was 980.118.

The National Bureau of Standards was interested in such a determination on its own account also, as the value of g enters into absolute electrical determinations such as that of the ampere by the current balance.

2. PREVIOUS ABSOLUTE DETERMINATIONS OF GRAVITY

Since the publication in 1906 of the result of the absolute determination of gravity at Postdam that station by common consent has been the accepted international base. The Potsdam value superseded all previous results such as those obtained in Austria and in Italy, and was regarded as the most precise and authoritative figure that had been obtained up to that time.

For this there was a special reason. All earlier determinations had involved an unrecognized error, arising from the flexure of the pendulum while swinging. Attention had been called to this point on purely theoretical grounds by C. S. Pierce¹ as early as 1884, but this calculated correction was so large as to seem incredible.

Ten years later the importance of this correction had been recognized by Helmert, whose calculations indicated that this error, while not as great as supposed by Pierce, was still to be regarded as one of the major corrections to be applied to the time of the swing. In the case of a rather flexible pendulum which had been newly constructed but never used, Helmert found by his formula a correction of as as much as 366 parts in a million in the value, of g . For a pendulum that had been actually used for gravity determinations in France, Helmert calculated the flexure correction to be 18 parts per million.²

The recognition of the importance of this correction caused Helmert to give special attention to this point in the Potsdam determination of gravity. This work, begun in 1898, was carried out by Kühnen and Furtwängler under Helmert's supervision. The published report, dated 1906, fills a large volume.

3. PLAN OF THE PRESENT DETERMINATION

There appears as yet to be no better method available for the absolute determination of gravity than that of the reversible pendulum. [807]

Study was given to other possibilities, such as the ring pendulum of Mendenhall,³ but none of these seemed sufficiently promising to be worthy of adoption.

Precision of length measurements would appear to call for as long a pendulum as possible, but this at present is about 1 meter. The use of a longer pendulum was felt to be inadvisable in view of the fact that the technique of

¹ U. S. Coast and Geodetic Survey, Report for 1884 Appendix 16.

² Helmert, Beiträge zur Theorie des Reversionspendels, p. 15 and 28, Potsdam, (1898).

³ Mendenhall, , Memoirs of the National Academy of Sciences, X, 1st Memoir (1905).

THE VALUE OF GRAVITY AT WASHINGTON

measurement of lengths of 4 or more meters, especially in a vertical position, as is necessary in pendulum work, is not yet sufficiently perfected to give the precision that can be obtained with length of 1 meter.

There is recorded⁴ the use of a pendulum 21 meters long, but the precision attained in the length measurements was only 0.1 mm, about 1 part in 200,000, whereas with a length of 1 meter a precision of 1 part in a million can be reached. It is to be said, however, that the disturbances arising from the imperfections; of the knife-edge, which (as will appear later) are serious, theoretically should diminish as the pendulum is made longer. Largely because of these errors the time of swing of a pendulum which superficially might appear capable of measurement to a precision much exceeding 1 part in a million, actually is limited to a precision less than that attainable in length measurements.

Because of the difficulty of measuring a length defined by two knife-edges, and because of the desirability of using several different knife-edges with the same pendulum, it was decided to use pendulums of the two-plane type. As was first shown by Bessel, this construction eliminates in theory the correction for radius of curvature of a knife edge.

One factor of uncertainty in pendulum work has always been the temperature correction. It was therefore decided to construct the three essential parts of the apparatus—the pendulum, the standard scale, and the backbone of the comparator—all of fused silica, thus rendering the temperature correction almost negligible.

II. THE OBSERVING ROOM

For the observing room there was available the constant-temperature vault of the National Bureau of Standards. This vault is that was used in the recent redetermination of the constant of gravitation.⁵ It contained a large and a small room. The clock was installed in the large room and the pendulum in the small room. An opening about 30 cm square in the partition wall allowed the observer at the pendulum to see the clock dial when necessary.

III. THE PENDULUM APPARATUS

1. THE PENDULUMS

The form of pendulum adopted was dictated by the nature of the material used (fused silica) and was of necessity simple. It was an approximation to a uniform straight rod supported at one end, for there is a second point of support with the same time of swing, situated at a point two-thirds of the distance to the other end of the rod. [808]

Each pendulum was made of a tube of fused silica. Four such pendulums were constructed, with different diameters to give varying flexibilities. To determine the flexibility, the pendulum was supported at two points near its ends, and a weight applied at the center. The bending was too small to be measured directly, but was determined by observing with a telescope the image of a distant scale reflected in a mirror attached to the end of the pendulum. In order to compare the flexibilities of the different pendulums the quantity $Q\mu/EI$ was calculated, in which

$$\begin{aligned} Q &= \text{Cross sectional area of the tube.} \\ \mu &= \text{Density,} \\ E &= \text{Young's modulus,} \\ I &= \text{Moment of inertia of cross section.} \end{aligned}$$

The silica tubes of which the pendulums were made were not perfectly uniform in cross section, but the above described procedure will give average values of EI and of $Q\mu$ (the mass per unit length). Let D be the distance between the points of support and F the weight applied. Then, since the bending is very small, we have at a point distant x from the point of application of F :

⁴ A. A. Ivanov, *Annals of the Central Bureau of Weights and Measures*, **11-12**, Leningrad. (1916-18.) (In Russian.)

⁵ *BS J. Research* **5**, 1243 (1930) RP256.

THE VALUE OF GRAVITY AT WASHINGTON

$$\frac{d^2y}{dx^2} = \frac{\text{Bending moment}}{EI} = \frac{F \left(\frac{D}{2} - x \right)}{EI}$$

$$\frac{dy}{dx} = \frac{F}{2EI} \left(\frac{Dx}{2} - \frac{x^2}{2} \right) = \frac{F}{4EI} (Dx - x^2)$$

The constant of integration is zero since $dy/dx = 0$ if $x = 0$, i. e., at the point of application of F . At the end of the pendulum where the mirror was mounted x is nearly $D/2$. At this point:

$$\frac{dy}{dx} = \frac{\text{observed angular displacement}}{2} = \alpha$$

We have then:

$$\frac{1}{EI} = \frac{16\alpha}{FD^2}$$

Table 1 gives the data necessary for the calculation of $Q\mu/EI$. The values of the relative flexibility in the last column are merely numbers proportional to $Q\mu/EI$. In measuring the value of α the distance from mirror to scale was from 1,000 to 1,300 cm.

TABLE 1.—*Properties of pendulums*

Pendulum number	Outside diameter cm	Inside diameter cm	D cm	Mass g	$Q\mu$ g/cm	F Dynes	α Radians	$1/EI$	$Q\mu/EI \times 10^{12}$	Relative flexibility
1	4	3.4	153.6	1,130	7.4	6.86×10^5	0.000 24	2.4×10^{-13}	1.8	1.00
2	4.5	3.4	154	1,927	12.5	6.86×10^5	0.000 13	1.3×10^{-13}	1.6	.89
3	5	3.6	161	3,620	22.5	2.24×10^6	0.000 17	4.7×10^{-14}	1.1	.61
4	7	5.8	157.5	3,532	22.7	3.43×10^6	0.000 11	2.1×10^{-14}	.5	.28

During the progress of the work pendulum no. 1 was broken, and the work was finished with the other three. The broken pendulum [807] was that one which, because of its greatest flexibility, would have had the least influence in determining the final result.

Each pendulum was provided with two planes, upon each of which it could be swung in turn. One of these planes was as near as possible to one end of the pendulum, and when swung on this plane the pendulum was said to be in the down position. The second plane was located approximately at the conjugate point giving the same time of swing and when swung on this plane the pendulum was said to be in the up position. Planes of two materials were used, fused silica and stellite

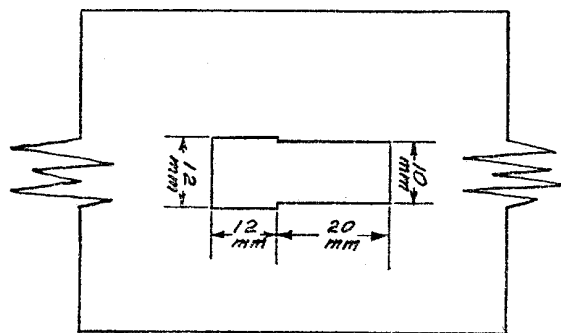

FIGURE 1-Opening in silica tube.

THE VALUE OF GRAVITY AT WASHINGTON

For the purpose of attaching the planes to the pendulum, openings of the size and shape shown in figure 1 were cut through both sides of the silica tube. Through the 10- by 20-mm opening was inserted a block (of silica or stellite) of that cross section and long enough to project slightly on each side of the tube. One face of this block was worked optically flat and furnished the plane by which the pendulum rested upon the knife-edge. The knife-edge in its mounting was inserted through the 12- by 12-mm opening, which allowed sufficient room for the swinging of the pendulum.

The large 20-mm faces of the block were polished, but not to the same degree of flatness as the lower face. In the stellite blocks these faces served directly as mirrors for observing the flash signals in measuring the time of swing. With the silica blocks it was found advisable to attach small silvered glass mirrors to these faces.

In addition, the stellite blocks carried on both 20-mm faces a set of fine ruled lines as shown in figure 2, where the blocks are shown removed from the pendulum with their optically flat faces *B, B* in contact. While pressed closely together in this position the distance between the horizontal lines was determined for later use in measuring the length of the pendulum.

An attempt to rule such lines on the fused-silica blocks was not encouraging. This material does not take a ruled line well, the edges of the groove being ragged and irregular. Others have found this difficulty and have attempted to overcome it by platinizing the silica surface and ruling lines through the platinum film only. Our experience with this has been that the lines are of nonuniform excellence, good in spots and ragged in others, due probably to a lack of uniformity in adhesion or thickness of the platinum film. For this reason we [810] adopted an indirect method of measuring the distance between silica blocks in the pendulum, which will be described later.

When the blocks were in place in the silica tube the mirror face and the set of measuring lines could be seen through openings cut in tubes as shown in figure 3.

At the end faces of all the blocks vertical lines were ruled marking the median plane of the block. In setting up the pendulum these lines were so adjusted that their prolongations intersected that of the knife-edge, which could be done to 0.1 mm. The error in the value of g arising from a variation in this adjustment is not capable of calculation. It is irregular and seems to depend upon a variation in properties of the different places in the plane which may be in contact with knife-edge. The experience of the U. S. Coast Survey has led them attach special importance to this point in the construction of their instruments for relative gravity work. By the use of a mechanical device for raising and lowering the pendulum the Coast Survey found that the knife-edge could be set repeatedly on the same position on the plane, and relative values of g accurate to 1 part in a million could be obtained. Without this precaution the results varied widely and irregularly.

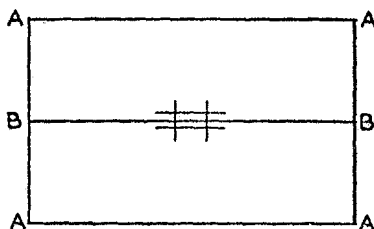

FIGURE 2.—Stellite blocks with ruled lines

The blocks required mounting in the pendulum with the faces *B, B* parallel. This was attained by an optical method. The silica pendulum tube was mounted in a brass tube or jacket and held in place by setscrews with lead pads. This brass jacket was less 100 cm long and enclosed that part of the silica tube between the places of support, allowing easy access to the holes and the blocks. The brass jacket was provided at each end with a circular ring or collar, on which the jacket and its contained silica tube could rotate on a support consisting chiefly of two parallel rods. This arrangement made it possible to rotate the slightly irregular silica tube about a definite axis (fig. 3).

The silica tube was adjusted by means of the setscrews so as to be as nearly as possible concentric with the brass jacket. One of blocks was then inserted in place and held by wooden wedges. A miniature 5-volt lamp was placed at the end of the silica tube and the image of the filament reflected from the face *B* of the block was observed with a telescope as the tube and brass jacket were rotated together. The image described a circle, showing that the plane *B* was not perpendicular to the axis of rotation.

Observation having indicated where the silica surfaces against which the face *A, A* rested needed grinding off, the block was removed and a little grinding done by means of a hand tool and a fine grade of carborundum powder. To

facilitate this process the silica bearing surfaces were cut so as to offer a three-point bearing for the block, one silica surface being cut out slightly at its center and the other at its ends. The block was then replaced and another observation taken. It was found possible by repeated trials to adjust the block so that the reflected image remained nearly stationary on rotating the tube. The precision of this adjustment is indicated by the following figures.

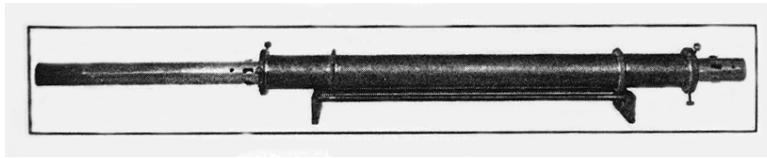

FIGURE 3.—Brass jacket supporting silica tube.

[811] The lamp filament was about 2 mm long, and as the tube was rotated the radius of the circle described by the image of the filament was in no case greater than about one-fifth the length of the filament. The distance from telescope to mirror was, at one end of tube, about 120 cm, and at the other end about 170 cm. The maximum departure from parallelism indicated by these figures is about 0.01°.

A departure from parallelism in the direction of the swing of the pendulum, perpendicular to the knife-edge, is of no importance. A departure in the direction of the knife-edge reduces the problem to that of the horizontal pendulum. As shown by Webster (Dynamics, p. 252) the length of the equivalent simple pendulum is increased in the ratio $1/\cos \theta$, where θ is the angle made by the knife-edge with the horizontal. When $\theta = 0.01^\circ$, $\cos \theta = 0.999\,999\,99$, and the correction is negligible.

Without disturbing the pendulum in its jacket the same process was carried out with the second block in its proper place. Each face B was thus set perpendicular to the same straight line, the joint axis of rotation of the tube and jacket, and hence the two faces B were parallel.

The blocks, held in position by wooden wedges, were then fastened in place by a suitable cement, none of which was allowed to reach the surfaces A, A . The best cement found for joining stellite to fused silica was red sealing wax. For joining silica to silica the best cement is fused chloride of silver, which melts at a moderate temperature.

It was possible to check the parallelism of the faces B, B after cementing by observing the reflection of the 5-volt lamp from one block with the other in place, there being sufficient space above and below the blocks to allow of this.

The next adjustment of the pendulum was that for equal times of on the two planes of support. To attain this, the silica tube, originally longer than necessary, was shortened by cutting off successive slices from its lower end, and finished by grinding slightly. A very accurate adjustment is thus easily possible. The necessity for this adjustment arises from the fact that the location of the center of gravity of the pendulum is not capable of determination with great accuracy. This defect may be counterbalanced by a sufficiently close adjustment of the two times of swing. The necessary approximation to equality of times is easily calculated.

The time of swing τ of the simple pendulum equivalent to a reversible pendulum of times of swing T_1 and T_2 is given by the formula:

$$\tau^2 = \frac{T_1^2 h_1 - T_2^2 h_2}{h_1 - h_2} \dots \quad (1)$$

where h_1 and h_2 , are the distances of the center of gravity from the two planes of support. If l is the distance between these two planes, $h_2 = l - h_1$ and eq 1 becomes

$$\tau^2 = \frac{T_1^2 h_1 - T_2^2 l + T_1^2 h_1}{2h_1 - l} \dots \quad (2)$$

Differentiating and reducing:

$$\frac{d(\tau^2)}{dh_1} = \frac{(T_2^2 - T_1^2)l}{(h_1 - h_2)^2}$$

[812] If τ is equal to $(T_1 + T_2)/2$, as will essentially be the case if τ , T_1 and T_2 are each nearly unity,

$$\frac{d\tau}{dh_1} = \frac{(T_2 - T_1)l}{(h_1 - h_2)^2} \dots \quad (3)$$

As a numerical example, let $l = 1,000$ mm, $h_1 = 700$ mm, $h_2 = 300$ mm, and $T_2 - T_1 = 0.0001$ second then

$$\frac{d\tau}{dh_1} = 0.000\ 000\ 6$$

Thus an error dh_1 of as much as 1 mm in locating the center of gravity would make a difference in the time of swing of but 6 parts 10 million. As the center of gravity of the pendulum could be readily located to one- or two-tenths of a millimeter an adjustment of times to 0.0001 second is sufficient for our purpose.

The theory of the reversible pendulum requires that the center of gravity shall lie in the plane of the two lines of support. When this is fulfilled other asymmetries in a pendulum of the form used by us, in which there are no interchangeable weights, are (in a vacuum) self-eliminating. This adjustment was tested as was done in the Potsdam determination, after the pendulums were adjusted to equality of times of swing, by hanging each pendulum on a knife-edge with fine plumb lines passing close to the ends of the blocks. When the lines on the upper block coincided with the plumb lines, those on the lower block were in no case more than 0.2 mm out of line. A departure of 0.2 mm in 1,000 mm is geometrically of no importance as the cosine of the angle is 0.999 999 98.

The temperature coefficient of expansion of fused silica was taken to be 0.000 000 6, and this will of course be the coefficient for a pendulum with silica blocks. With stellite blocks in a silica pendulum it is a more complicated question. The coefficient of expansion of stellite varies with different samples from 0.000 011 to 0.000 015. The value of 0.000 013 was assumed in this case.

Assuming the blocks to be always be in contact with the silica bearing surfaces, and any differential expansion along the 2 cm width of the block to be taken up by the cement, we may calculate the net change of length between the planes of support B . Taking the distance between these planes to be approximately 100 cm we have:

$$104 \times 0.000\ 000\ 6 - 4 \times 0.000\ 013 = 0.000\ 062 - 0.000\ 052 = 0.000\ 010$$

Dividing by the length, 100 cm., we obtain for the coefficient of expansion 0.000 000 1, about one-sixth that of an all-silica pendulum. Assuming the value of 0.000 011 for the coefficient of stellite, the coefficient of the pendulum becomes 0.000 000 18.

The temperature coefficient of time of swing will not be the same as that of linear expansion. For an all-silica pendulum, since the time of swing is proportional to the square root of the length, the time coefficient will be one-half the length coefficient, or 0.000 000 3. For a silica pendulum with stellite blocks the matter is not quite so simple.

Since the mass of a stellite block is small compared to that pendulum (from 4 to 8 percent) we may (as far as mass is concerned) [813] assume the pendulum, swung in either position, to be a uniform rod pivoted at a distance h from its center of gravity. The radius of gyration of the pendulum, about an axis through its center of gravity be denoted by k . For a uniform rod, $k^2 = L^2/12$, where L is the total length of the rod. The time of swing in either position will be given by

$$T^2 = \frac{\pi^2}{g} \left(\frac{k^2 + h^2}{h} \right) = \frac{\pi^2}{g} \left(\frac{L^2}{12h} + h \right)$$

Differentiating with respect to the temperature t :

THE VALUE OF GRAVITY AT WASHINGTON

$$\frac{d(T^2)}{dt} = \frac{\pi^2}{g} \left[\frac{12h \times 2L \frac{dL}{dt} - L^2 \times 12 \frac{dh}{dt}}{12^2 h^2} + \frac{dh}{dt} \right]$$

Since T is nearly 1 second:

$$\frac{dT}{dt} = \frac{\pi^2}{2g} \left[\frac{L}{6h} \frac{dL}{dt} + \frac{dh}{dt} \left(1 - \frac{L^2}{12h^2} \right) \right] \dots \quad (4)$$

In all the pendulums we have approximately

$$\begin{aligned} L &= 155 \text{ cm} \\ h &= 70 \text{ cm (down)} \\ h &= 30 \text{ cm (up)} \end{aligned}$$

In the down position we have, therefore,

$$\frac{L}{6h} = 0.37$$

$$\frac{L^2}{12h^2} = 0.41$$

$$\frac{dL}{dt} = 155 \times 0.000\,000\,6 = 0.000\,093$$

$$\frac{dh}{dt} = 72 \times 0.000\,000\,6 - 2 \times 0.000\,013 = 0.000\,017$$

Substituting in eq 4

$$\frac{dT}{dt} = 0.000\,000\,22 \dots \quad (5)$$

For the up position

$$h = 30 \text{ cm}$$

$$\frac{L}{6h} = 0.86$$

$$\frac{L^2}{12h^2} = 2.22$$

$$\frac{dh}{dt} = 32 \times 0.000\,000\,6 - 2 \times 0.000\,013 = -0.000\,007$$

[814] Substituting in eq 4

THE VALUE OF GRAVITY AT WASHINGTON

$$\frac{dT}{dt} = 0.000\ 000\ 45\dots \tag{6}$$

As a check on eq 4 we may calculate the time coefficients for an all-silica pendulum in the two positions. In the down position $dh/dt = 70 \times 0.000\ 000\ 6 = 0.000\ 042$ and in the up position $dh/dt = 30 \times 0.000\ 000\ 6 = 0.000\ 018$. The other quantities remain the same. Substituting in eq 4 the coefficient in each position comes out 0.000 000 29, a satisfactory agreement with 0.000 000 3, obtained by taking half of the coefficient of linear expansion.

The temperature corrections to the time of swing given by eq 5 and 6 were applied to each time of swing, down and up, as these were obtained, and the corrected values of T_1 and T_2 thus obtained were used in eq 1 to calculate τ^2 and finally g . No correction of h_1 or h_2 for temperature is necessary in eq 1, as the h values need be known only to four figures to insure a value of g accurate to 1 point in a million.

2. THE SUPPORTING APPARATUS AND VACUUM CASE

The knife-edge upon which the pendulum swung was mounted in a steel support (later to be described) of such a size that it could pass through the 12-mm-square hole in the pendulum with room enough to spare for a reasonably large amplitude of swing. This steel support rested at its ends in notches cut in a heavy brass ring (fig. 4), which in turn was screwed down over a hole in a heavy steel shelf which rested on large cast-iron wall brackets (fig. 5).

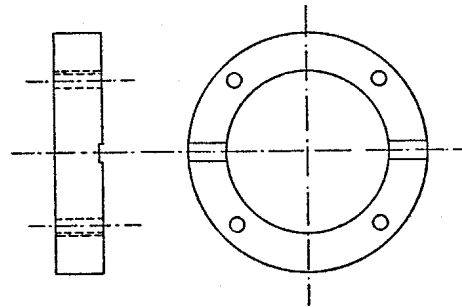

FIGURE 4.—Brass ring support for knife-edge.

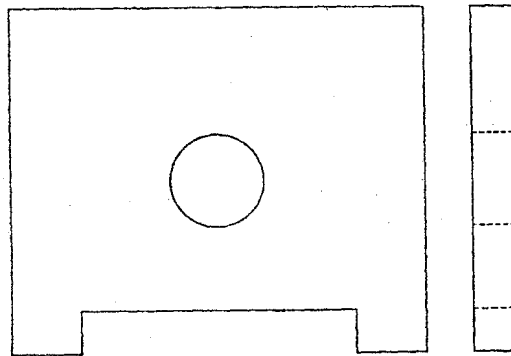

FIGURE 5.—Steel shelf.

The shelf and bracket supporting the pendulum were made especially massive and rigid in order that any motion of the support arising from the swinging of the pendulum should be as little as possible. The cast-iron brackets, weighing about 50 kg each, were bolted into a large mass of concrete imbedded in the brick wall of the room. The wall was hollowed out to a depth of about 75 cm, the cavity being made wider as it became deeper, dental fashion. Boards were placed across the cavity, which was about 1 meter square, and bolts set in proper position in one of the

THE VALUE OF GRAVITY AT WASHINGTON

boards with their heads in the cavity. The cavity was then filled with concrete. When the boards were removed the brackets were fitted over the projecting bolts and fastened in place by nuts.

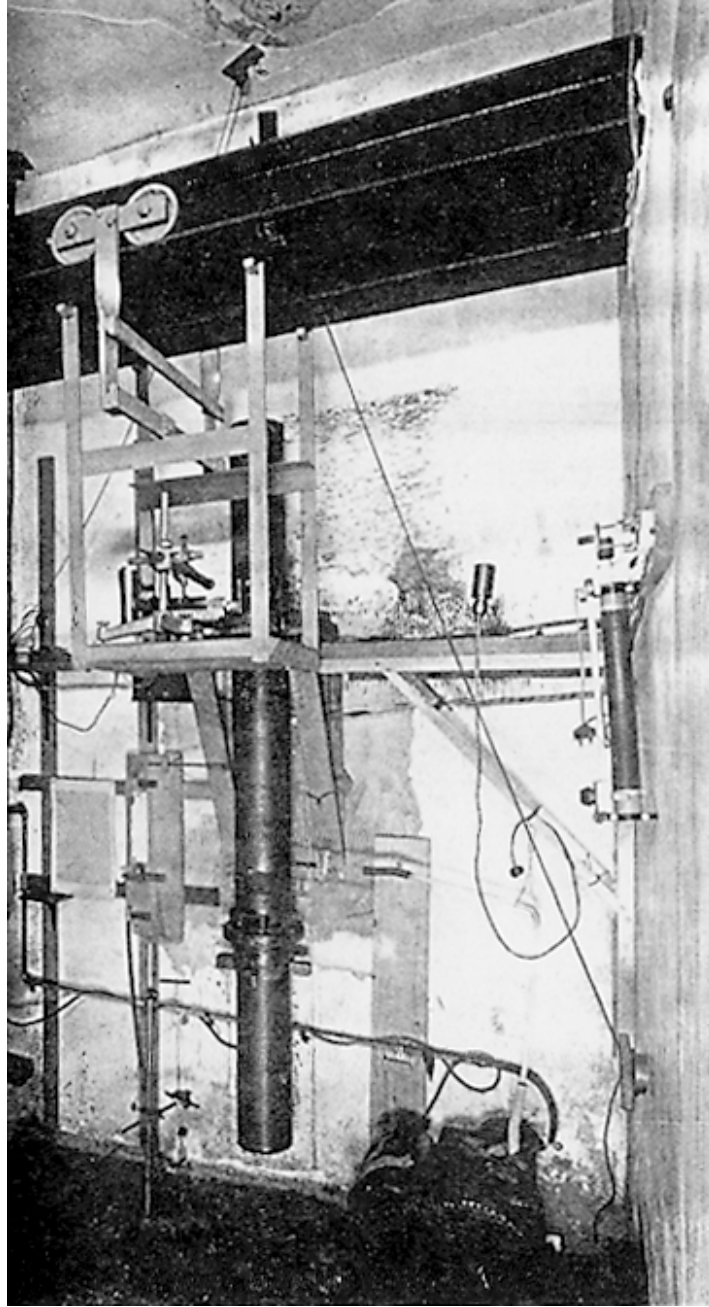

FIGURE 6.—*Vacuum case for pendulum.*

[815] The steel shelf resting on these brackets was 40 cm square and 4 cm thick, with a circular hole 9 cm in diameter over which the brass ring was fitted. This ring carried two bolts 180° apart which passed loosely through the ring and screwed into the steel shelf. There were also two other bolts at 90° from the first pair which screwed through the ring and pushed against the shelf. By means of these pulling and pushing bolts the ring and knife-edge could be levelled.

THE VALUE OF GRAVITY AT WASHINGTON

A departure from level would theoretically alter the time of swing. If θ is the angle made by the knife-edge with the horizontal the length of the equivalent simple pendulum will be increased in the ratio $1/\cos \theta$. The level used would indicate a difference of 0.001 radian, of which the cosine differs from unity by 5 parts in 10 million.

Apart from this geometrical effect there is the possibility of disturbing the time of swing by increasing the pressure on one-half of the knife-edge and decreasing it on the other. A number of experiments were made to test this point. Thin slips of sheet metal were inserted under one end or the other of the knife-edge, by which the level could be altered by steps of 0.001 radian. With differences of as much as 0.004 radian or more on either side there was always a consistent diminution of the time of swing, but for angles differing 0.001 or 0.002 from the bubble level the effects were entirely regular and of the same order of magnitude as were encountered on different settings at the bubble level.

The vacuum case was of brass tubing 16 cm inside diameter, and made in three sections (fig. 6). The central section was bolted at its upper end to the underside of the steel shelf, and to its lower was bolted the bottom section. The upper section rested by its weight on the upper side of the steel shelf. Joints were made air-tight by a rosin-beeswax mixture.

The central and lower sections of the vacuum case were never moved from position, but the upper section had to be lifted and swung away every time the pendulum was to be reversed. For this purpose a pulley arrangement was provided.

Glass windows were provided in the pendulum case wherever necessary such as where flash observations for coincidences were to be made, or where the amplitude of swing was to be measured. In the early stages of the work the amplitude was measured by observing lower part of the pendulum by means of a traveling microscope. [816]

Later this measurement was made by a beam of light reflected from the upper stellite or silica block to a scale about a meter away.

Outlets were provided in the central section for the pump connection and for the pressure gage. A gage of the McLeod type was used. Another outlet in the bottom section was provided with a glass stopcock which served as a pneumatic starter for the pendulum. In the early stages of the exhaustion puffs of air were admitted through this outlet until a suitable amplitude was obtained. The stopcock was then closed and the exhaustion finished to less than 0.1 mm.

Early in the work a quantity of radioactive sand was placed in the bottom of the vacuum case to provide against electrification of the pendulum. On comparing results obtained before and after introducing the sand there was no evidence that it was needed. However, it was allowed to remain in the case for the whole duration of the work.

3. THE KNIFE-EDGES

Several materials were tried for knife-edges—fused silica, agate, stellite and steel. The behavior of these different materials will be later described.

The silica and agate edges were mounted in a groove in a bar of steel, and held in place either by cement or clamping pieces of metal. The stellite and steel edges were made in one piece, long enough to rest in the grooves in the brass ring and heavy enough to bear the weight of the pendulum, about 1 cm wide and high. The working edge was ground to an angle of about 135° , and was cut away for a space of from 1 to 2 cm in the middle to prevent walking of the pendulums.

No knife-edge can be ground to a geometrically perfect edge nor is it advisable that it should be. On such an edge any finite load, however small, would produce an infinite pressure and a consequent breakdown of the edge. In *Zeitschrift für Instrumentenkunde*, January 1932, Schmerwitz describes a method for measuring the radius of curvature of a knife-edge. We have constructed an apparatus such as was used by Schmerwitz and find that his method can be used in practice with an accuracy of about 15 percent. Values for the radius of knife-edges, to be mentioned later, were obtained in this way.

IV. MEASUREMENT OF LENGTH

1. THE STANDARD SCALE

The standard scale was constructed of a piece of fused silica tubing about 18 mm in diameter and a little over 1 m long. Near each end the tube was cut half way through and a flat silica plate fastened by fusion in the diametral plane

THE VALUE OF GRAVITY AT WASHINGTON

of the tube (fig. 7). These plates were about 12 mm wide and were so placed that the centers were about 995 mm apart.

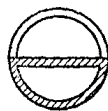

FIGURE 7.—*Cross section of silica scale.*

Silica scales have been constructed and observed over a considerable period of time at the National Physical Laboratory, in England, where it was found, as we have also observed (section III: 1), that silica does not receive or preserve graduations well, the material tending to flake off at the scratches. For this reason the National Physical Laboratory platinized portions of the silica surface and ruled lines through the thin coat of platinum without scratching the silica beneath.

This plan was tried by us, but difficulty was found in obtaining a coat of platinum that would give good lines at all places. Usually spots could be found upon which excellent lines could be ruled, but at other places it was not possible to do so well. For this reason a different plan was finally adopted.

The Hanovia Chemical and Manufacturing Co. constructed for us a scale with short pieces of tungsten rod fused into the flat silica plates. To these tungsten rods pieces of sheet platinum about 1 mm thick were silver-soldered. After polishing the faces of the platinum pieces it was found possible to rule excellent lines upon them. Lines were ruled approximately 0.25 mm apart, giving lengths varying from about 994 to 999 mm. This scale was calibrated by comparison with a standard meter bar in the Length Section of the National Bureau of Standards. A copy of the report of these measurements follows.

INTERVALS ON PLATINUM-FACED SILICA SCALE

IDENTIFICATION NO. 2

(Graduated by National Bureau of Standards, Division II-1)

This bar, when supported at the two neutral points, has been compared with the standards of the United States, and the intervals indicated were found to have following lengths at 20 °C.

Intervals	Length (mm)
0 to 0	993.9869
5 to 5	996.4866
10 to 10	998.9812

Left-end intervals	Length mm	Right-end intervals	Length mm
0 to 1	0.2502	0 to 1	0.2498
1 to 2	.2490	1 to 2	.2504
2 to 3	.2502	2 to 3	.2503
3 to 4	.2494	3 to 4	.2495
4 to 5	.2504	4 to 5	.2494
5 to 6	.2490	5 to 6	.2500
6 to 7	.2495	6 to 7	.2477
7 to 8	.2493	7 to 8	.2540
8 to 9	.2503	8 to 9	.2497
9 to 10	.2475	9 to 10	.2491

The above values are not in error by more than 0.0010 mm.

The observations were taken at a mean temperature of 28.30° C and in reducing to 20° C the coefficient of expansion of the silica bar was assumed to be 0.000 000 6 per degree centigrade.

[818] The scale was mounted for protection in a brass tube with openings to permit the graduated portions to be seen. Since the scale was to be used in a vertical position the brass tube was so arranged that the scale could be

THE VALUE OF GRAVITY AT WASHINGTON

supported at either the bottom or the top. A series of observations failed to show any observable difference in length in the two cases. Calculations indicated that such a change would be a small fraction of 1 micron, and our length measurements were good only to 1 micron. As a matter of convenience, therefore, the scale was always supported at the bottom.

2. THE MICROSCOPES

Two micrometer microscopes, of the Geneva Society's make, were employed in this work. Rather a long focus (about 2.5 cm) necessary in order to reach the blocks inside the pendulum tubes. These microscopes were tested by the Length Section of the National Bureau of Standards for periodic and progressive errors and for average value of one revolution of the drum, which carried 100 divisions. In each case the error was found to be less than one division on the drum. Each microscope was adjusted so that one revolution equalled 100μ to better than 1 part in 1,000. The scopes were provided with vertical illumination.

3. THE COMPARATOR

The comparator was built to handle the scale and pendulum in a vertical position. The most important part was the backbone which carried the two microscopes. This was made of a piece of silica tubing 3.5 cm in outside diameter, with walls about 4 mm thick. At the ends of the tube V-shaped notches were cut in which the microscopes were held by a clamp of the form shown in figure 8. This backbone was mounted in the metal framework of the comparator in a vertical position, held near its upper end by a brass collar in a gimbal bearing, and fastened near its lower end by three setscrews pressing against a second brass collar. Both collars were fastened to the tube by DeKhotinsky cement.

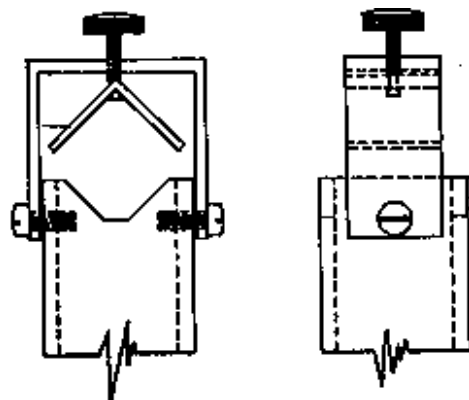

FIGURE 8.—Clamp for microscopes.

[819] In the measurement of an all-silica pendulum against a silica scale there is no differential temperature coefficient of importance. The coefficient of different samples of fused silica at 20° C may vary by 2 parts in 10^7 , while the precision of our measurements does not exceed 1 part in 10^6 . Nor is the question of temperature gradients serious. As may be seen by fig. 9, the pendulum, the silica scale, and the backbone of the comparator were all within about 15 cm of each other.

With the pendulums carrying stellite blocks the case will be different. The coefficient of the expansion of fused silica being 0.000 000 6 and that of the pendulum (see Section III, 1) 0.000 000 1, it follows that there will be a differential expansion coefficient of the scale over that of the pendulum of 0.000 000 5. A knowledge of the temperature to the nearest degree would therefore ensure a precision in the comparison of scale and pendulum to 1 part in 2 million. As a matter of fact the temperature was always to tenths of a degree. The temperature in the observing room changed by so small a fraction of a degree during such a comparison that the expansion of the comparator backbone was of no consequence.

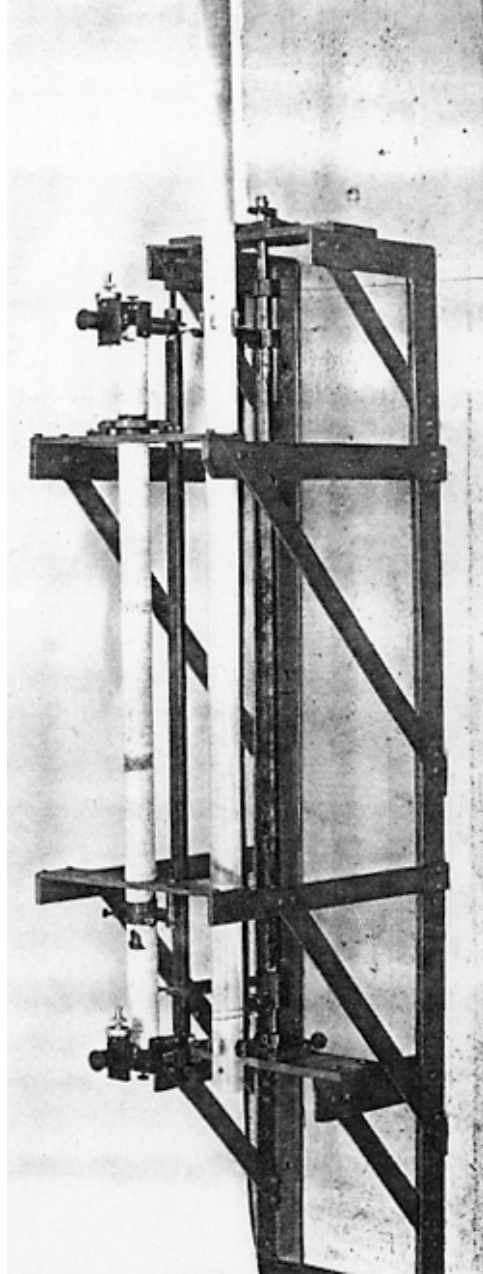

FIGURE 9.—*Comparator.*

For the general structure of the comparator a comparatively brief description will suffice. Its general appearance is shown in figure 9. The pendulum and scale were supported side by side by means of short arms projecting radially from a vertical rod. By turning this rod either pendulum or scale could be brought into view in the microscopes. Focusing was done by moving this vertical axis forward or backward at each end by a screw motion, the microscopes remaining fixed in position. The vertical axis could also be raised or lowered as desired.

The length of the silica backbone was adjusted so that measurement lines on the pendulum appear near the center of the field of each microscope. To allow for slight differences in the length of the different pendulums thin sheets of copper or aluminum were introduced between the microscope barrel and the notch in which it rested in the silica tube.

The pendulum was supported in the comparator at its upper plane upon a brass strip with a small vertical projection at its center, thus allowing the pendulum freedom of motion in two directions for purposes of alignment.

THE VALUE OF GRAVITY AT WASHINGTON

At its lower end the pendulum was held by a rubber band against two setscrews in a Y-shaped support. By means of these screws and the upper pivot support the pendulum could be adjusted to the vertical. In addition, coarse adjustment was possible by rotating separately the projecting radial arms carrying the pendulum about the central axis of the comparator.

4. METHODS EMPLOYED

The measurement of the distance between the planes was most easily carried out with the stellite blocks. Before inserting the blocks in the pendulum they were pressed together at their optically flat surfaces and the distance between the ruled lines determined (fig. 2). After the blocks were set in place measurements were made on both [820] the front and back sides to eliminate any lack of parallelism. A typical example of such a length measurement follows:

	Back position.	Temperature 24.3°	
	Scale distance used, 997.9854 mm at 20.0°		
	Micrometer microscope readings, mm:		
	Pendulum		Scale
	Lower	Upper	Lower Upper
	0.6467	0.3550	0.7101 0.3804
	.6465	.3544	.7102 .3804
	.6467	.3540	.7102 .3804
	.6467	.3542	.7100 .3806
	<u>.6464</u>	<u>.3548</u>	<u>.7101</u> <u>.3802</u>
Mean _ _	0.6466	0.3545	Mean _ _ 0.7101 0.3804
	<u>0.3545</u>		<u>0.3804</u>
$\Delta P =$	0.2921		$\Delta S =$ 0.3297
			$\Delta P =$ 0.2921
			Scale-pendulum = 0.0376 mm at 24.3°
			= 0.0354 at
			20.0°
			Scale = <u>997.9854</u> at
			<u>20.0°</u>
			Pendulum = 997.9500 at 20.0° between lines
			Correction for lines _ _ _ _ <u>0.799</u>
			Length between planes = 997.151 mm at 20.0°

In the foregoing example the quantity ΔP is the amount to be added to the distance between the zero points of the microscopes to give the distance between the measuring lines on the pendulum, and ΔS is a similar quantity for the scale. By subtraction we obtain the difference between the scale and the pendulum.

In the case of the pendulums provided with silica blocks the measurement of length offers more difficulties. It is not practicable to rule lines on fused silica (section III, 1) and the first method tried for measuring the distance between the planes was Fizeau's "point and image" method used in end-standard measurements. In this method the point of a needle is placed against the plane and the cross wire of the microscope set on the junction of the point and its reflected image. This method offers considerable experimental difficulty. Much depends on the precision of focusing, and as but half the lens is used, an objective of high perfection is required. Berndt-Schultz (Grundlagen und Geräte technischer Längemessungen, page 23) says: "In spite of this, the precision of optical measurements on end-standards is about 5 times less than on line standards * * *. By the use of other objectives the error may be as large as 3.5 μ ."

The end-standards spoken of here are the polished faces of the metal bars. Rather unexpectedly, we have found that the difficulty is still further multiplied when dealing with transparent material such as fused silica. The same microscopes that will give acceptable results on metal faces give abnormally variable results on faces of fused silica. In one case it was observed (through the microscope) [821] that as the needle steadily approached the surface its image halted for an instant and then resumed its motion.

THE VALUE OF GRAVITY AT WASHINGTON

It being thus out of the question to apply the "point and image" method to fused silica, recourse was had to contact blocks. Two small blocks of stainless steel were ruled with lines close to their edges as with the stellite blocks, and the distance between the lines was determined when the blocks were pressed together. By a suitable clamping device one stainless steel block was pressed tightly against each silica block. In this way the problem was converted from one of an end-standard to one of a line standard

V. MEASUREMENT OF TIME

1. THE CLOCK

A Shortt clock was employed to furnish second signals for the measurement of the time of swing. This form of clock and its performance are so well known from the work of Loomis⁶ that no additional description is called for. In setting up the master clock in the room of the constant temperature vault it was found necessary to enclose it in a thermostatically regulated case as a precaution against the presence of the observer with a light burning. The small room in which the pendulum was swung was kept dark and was entered only to observe coincidences.

2. THE TIME-SIGNAL SYSTEM

The use of mechanical relays in transmitting time signals is to be avoided in precision work. The variable friction involved in the moving parts and the fluctuations in the strength of the current that operates the relay usually combine to produce errors of several thousandths of a second. For the rating of a clock such errors may be of little importance, but for coincidence observations they are more serious. For this reason the time-signal system was arranged to give signals without involving moving parts.

The case of the master clock was provided with a plate-glass bottom through which a beam of light was reflected from a small concave mirror attached to the lower end of the pendulum. The source of light was a straight-filament lamp, and the reflected image of the filament passed back and forth across a photoelectric cell contained in a brass tube provided with an adjustable slit. The electrical impulses from this cell were amplified until the energy was sufficient to operate either the flash system or the chronograph used for rating the clock.

The flash system employed was a neon-glow lamp mounted near the case in which the pendulum was swinging. By a simple optical system the flashes were sent through a slit to the polished face of the stellite block in the pendulum and back to an observing telescope.

In the course of the work it became necessary to observe at smaller amplitudes than was at first contemplated, and an increase in magnifying power seemed advisable. To obtain more light under these conditions a complex arrangement was tried containing a *KV610* neon-grid glow tube which carried a very heavy discharge. This proved unsatisfactory, apparently because of a pronounced and [822] variable after-glow amounting at times to several hundredths of a second. For this reason we returned to the use of the simple circuit containing a neon lamp, with which this effect appeared to be negligibly small or nearly constant.

3. METHOD OF OBSERVING

For observing coincidences the telescope was provided with a micrometer eyepiece, the cross hairs of which could be set at the position at which coincidences took place. Because of a slight departure from symmetry in the setting of the photoelectric cell with respect to the clock pendulum, it usually happened that there would be a slight difference in the coincidence interval (and position) according as the end of a coincidence interval occurred during a downward or an upward motion of the flash. This variation was eliminated by using an even number of coincidence intervals for the calculation of the time of swing.

This method of observing enabled us to detect readily any irregularity in the action of the relay transmitting the signals. The flashes appeared alternately above and below the cross hairs of the microscope, gradually approaching the coincidence position. In our earlier work we attempted to use signals from a Riefler clock transmitted through a mechanical relay. The flashes, instead of approaching regularly the coincidence position, would frequently exhibit a retrograde motion. With the photoelectric outfit this was never noticed.

⁶ Monthly Notices of the Royal Astronomical Society **91**, 569-575 (March 1931).

THE VALUE OF GRAVITY AT WASHINGTON

In changing the pendulum from the down to the up position it was rotated about its right and left axis, so that what was formerly the front side now became the back. The two positions of swing were denoted by the terms "front-down" and "back-up", respectively

A typical example of the measurement of time of swing follows:

Pendulum no. 2. Front-down position. Pressure 0.04 mm of Hg; temperature range (23.6° C. 23.8° C).

Amplitude	Time	Coincidence s	Interval
<i>Radians</i> 0.0047	8: 22	8:35:03	<i>Seconds</i> 449
.0016	11:30	8:42:32	450
.0011	12:30	8:50:02	
.0009	1:00	(8 intervals)	449.9
.0007	1:30	9:50:01	
		(8 intervals)	450.0
		10: 50 01	
		(7 intervals)	450.1
		11:42:32	
		(8 intervals)	450.3
		12:42:34	
		(7 intervals)	449.9
		1:35:03	453
		1:42:36	428
		1:50:04	

[823] It will be noticed that the interval between coincidences is nearly constant except toward the end, where because of the small amplitude observing was more difficult. To obtain the mean interval the average of the first three times of coincidence was subtracted from the average of the last three, and the difference divided by the number of intervals represented.

$$\begin{array}{r}
 \text{Average of last three} \text{ -----} 13:42:34.3 \\
 \text{Average of first three} \text{ -----} 8:42:32.3 \\
 \hline
 5:00:02.0 = 18\ 002 \text{ seconds}
 \end{array}$$

Dividing by 40 we obtain 450.05 seconds for the mean interval. This corresponds to a time of swing of 1.002 227 0 seconds.

The correction for temperature, by eq 5 is $-0.000\ 000\ 8$. The correction for arc, obtained by Borda's formula (U. S. Coast and Geodetic Survey, Special Publication No. 69, Modern Methods for Measuring the Intensity of Gravity, page 74) is $-0.000\ 000\ 2$. Applying these corrections we obtain for the time of swing 1.002 226 0 seconds at 20° C and zero amplitude.

The correction for clock rate was applied later in the computation of g .

4. CORRECTIONS

(a) CLOCK RATE

The Shortt clock was compared with the time signals from the U.S. Naval Observatory and with those from a crystal clock in the radio section of the National Bureau of Standards. The average daily rate of the Shortt clock was

THE VALUE OF GRAVITY AT WASHINGTON

about -0.04 second over the period covered by the results given in this paper. During this period the rate was remarkably constant, its daily variation seldom reaching the decimal place. While it is possible, as Loomis has shown, to obtain a much smaller rate from a Shortt clock this precision was ample for our requirements. Were this rate neglected altogether the error in the value of g would not exceed 1 part in a million.

(b) TEMPERATURE

The temperature of the pendulum was assumed to be that of the brass vacuum case, as measured by a thermometer on the outside of the case. After sealing the case the apparatus was allowed to stand overnight before observations were made. In correcting the time of swing for temperature the values given in tables 5 and 6 for the down and up positions were used for pendulums in stellite blocks and 0.000 000 3 for both positions of the all-silica pendulums.

(c) MOTION OF THE SUPPORT

Helmert (Beiträge, page 70) gives the mathematical theory of the effect of motion of the support on the time of swing of a pendulum, quoting an earlier investigation by C. S. Peirce, and confirming his result. If a pendulum of mass M swinging through an arc θ produces a horizontal elastic displacement of the support,

$$\sigma = \frac{Mgh\theta}{\epsilon l}$$

[824] in which ϵ is an elastic constant. Helmert also finds the alteration the equivalent length l of a simple seconds pendulum to be given the equation:

$$l' = l \left(1 + \frac{Mgh}{\epsilon l^2} \right)$$

From these two equations it follows that the apparent increase in the length of the pendulum

$$\delta l = l' - l = \frac{Mgh}{\epsilon l} = \frac{\sigma}{\theta}$$

or

$$\frac{\delta l}{l} = \frac{\sigma}{l\theta}$$

Since, δl is very small compared to l , this is equivalent to saying that the pendulum may be regarded as oscillating about a new center elevated by δl above the moving axis of support.

The correction for the motion of the support thus requires a knowledge of the arc of swing and the displacement of the support. The displacement may be observed directly by an interferometer as is done by the U. S. Coast and Geodetic Survey, or may be calculated by its effect in producing motion in an auxiliary pendulum as was done by the Potsdam observers. In the present work the interferometer method was employed. A small optically flat disk of fused silica was mounted by a little wax on one end of the knife-edge, which could be exposed for this purpose by moving the pendulums slightly to one side.

A specially built interferometer tube carrying a second flat plate and a helium tube for illumination, was mounted on a support independent of the steel shelf that carried the pendulum case. The interferometer tube could be moved back and forth by a screw motion so that the two flat plates could be adjusted to give fringes.

In addition to testing the motion of the knife-edge itself, the test plate was mounted also on the steel strip which carried the knife-edge, and on the brass ring.

THE VALUE OF GRAVITY AT WASHINGTON

In these interferometer experiments a double-amplitude arc swing of 0.06 radian was used instead of the smaller arc of 0.01 radian employed in time of swing measurements. With this large arc the motion of the brass ring was observable in any case.

When the test plate was mounted directly on the knife-edge there was, in most of the cases comprised in our results, no shift perceptible. In a few cases there was a slight motion, but this never exceeded one-tenth of a fringe. With a wave length of 0.6μ an observed shift of 0.1 fringe corresponds to a motion of the test plate of 0.3μ which gives for the correction to the pendulum length

$$\delta l = \frac{\sigma}{\theta} = \frac{0.03\mu}{0.06} = 0.5\mu$$

a maximum error of 1 part in 2 million.

(d) DAMPING

There are two sources of damping to be recognized in pendulum work. The first arises from the surrounding air and the second from friction at the knife-edge. These may be distinguished by the fact [825] that air friction, at the velocities to be encountered in a seconds pendulum, may be considered as proportional to the velocity, and that therefore amplitude will decrease as an exponential function of the time, while damping due to friction at the knife-edge can not be expected to follow any such simple mathematical law.

An examination of the amplitude-time curves for our pendulums shows that the curves are closely exponential throughout. We may therefore conclude that the air damping is the principal factor to be considered, and that knife-edge friction is negligibly small in comparison.

The most accurate test of this point is furnished by swings through large amplitudes. An example of such a swing follows:

Pendulum no. 4. Up position. Stellite knife-edge and plane. Pressure range (mm of Hg) {0.05 - 0.04}; temperature range {21.5° C. — 21.7° C}.

Amplitude	Time	$A_t = A_0 e^{-kt}$	k
	Δt	Minutes	
Radians 0.0236	9:44	----- 76	----- 0.0095
.0115	11:00	----- 64	----- .0096
.0062	12:04	----- 84	----- .0090
.0029	1:28	-----	-----

The period of a damped vibration where the damping effect is assumed proportional to the velocity is

$$T = \frac{\pi}{\sqrt{\frac{g}{l} - b^2}} = \pi \sqrt{\frac{l}{g} \left[1 + \frac{b^2 l}{2g} + \dots \right]} \dots \tag{7}$$

for which

$$b = \frac{1}{nT} \log_{\epsilon} \left(\frac{\alpha_0}{\alpha_n} \right)$$

n = total number of swings.

α_0 = initial amplitude.

THE VALUE OF GRAVITY AT WASHINGTON

α_n = final amplitude.

The shortest duration of swinging with any of our pendulums was about 3 hours, or 10,800 seconds. The ratio α_0/α_n was usually about 10. Since T is very nearly 1 second, these figures give $b = 0.000\ 21$ and $b^2 = 0.000\ 04$. Taking $l = 100$ and $g = 980$ the corrective term $0.000\ 002$, a negligible amount.

(e) RESIDUAL AIR

In addition to contributing to the damping effect discussed in the preceding section, the surrounding air gives rise to another effect resulting jointly from hydrodynamic loading and from buoyancy.

By hydrodynamic loading there is an apparent increase in the inertia of the pendulum, and because of buoyancy there is an apparent diminution in weight. Both factors increase the time of swing. [826]

This correction is best handled experimentally. Pendulum no. 1, the smallest and lightest of the set, was swung in air at different pressures in both the up and down positions with the following results:

Pressure	Time of swing	
	Up	Down
mm of Hg	<i>Seconds</i>	<i>Seconds</i>
0.1	1.0029	1.0029
100	1.0032	1.0032
425	1.0040	1.0042
760	1.0047	1.0050

These results are represented graphically in figure 10.

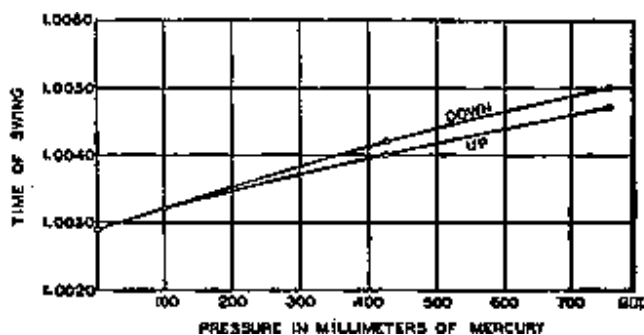

FIGURE 10.-Relation between pressure and time of swing.

It will be assumed that both curves are sufficiently linear to enable us to calculate that the difference of time to be expected between the pressure at which the pendulum was usually swung (less than 0.1 mm.) and a perfect vacuum is only 0.000 000 3 second, a negligible amount.

(f) COMPRESSIBILITY OF THE PENDULUM

It was suggested to us by Dr. C. Moon of our staff that consideration should be given to the question of a possible change of dimension of the pendulum arising from the difference in pressure at which its length was measured and that at which its time of swing was determined.

The compressibility of fused silica has been determined to be about 3.1×10^{-6} per megadyne/cm².⁷ Assuming the material isotropic we may take one-third of this as the linear change. In consequence, the length in a vacuum may be expected to be greater than that in air by about 1 part per million.

⁷ Adams, Williamson, and Johnston, J. Am. Chem. Soc. **41**, 39 (1919).

THE VALUE OF GRAVITY AT WASHINGTON

The compressibility of brass is about one-fourth of that of fused silica hence such a correction would not be likely to arise with metal pendulums.

To test this point experimentally a brass tube was provided, large enough to hold the no. 2 pendulum. The ends were closed airtight and windows were provided through which the length of the pendulum [827] could be measured. Measurements were taken with the tube alternately filled with air and evacuated to a pressure less than 5 mm.

The precision of the measurements was such that a change of 1μ could be safely recognized, but fractions of a micron were uncertain. As a mean of over a hundred measurements it appeared that there was a slight elongation of the pendulum in the vacuum, certainly less than 1μ , and apparently of the order of 0.5μ

The figure quoted for the compressibility of silica would indicate a change of about 1μ , but it is to be remembered that this figure was obtained at very high pressures. It is quite probable that the compressibility at 1 atmosphere may be less. However, a correction of the order indicated, 0.5μ is too small to be certain of with the precision of our length measurements, and in any case would influence the value of g by less than 1 part in a million. It may therefore be neglected

(g) FLEXURE OF THE PENDULUM

As a pendulum swings, it bends slightly, and from purely geometric considerations its mean length and time of swing should be less than with a perfectly rigid pendulum. Calculation of the difference between the arc and the chord shows, however, that such an effect, with pendulums of the rigidity usually employed, is negligible.

Experimentally, it is found that there is a rather large effect of flexibility on time of swing resulting from bending stresses in the opposite direction from that indicated above, increased flexibility giving a greater time of swing. This effect is present in both the up and down positions, and partly cancels out in applying eq 1.

This is illustrated by some preliminary experiments of ours with a pendulum composed for the most part of a strip of brass 37 mm wide and 3 mm thick. The pendulum carried two planes and could be hung on a fixed knife-edge either in the plane of the strip or perpendicular to it. This amounted to swinging two pendulums differing greatly in flexibility. Because of its slightly greater moment of inertia the rigid pendulum should have the greater time of swing. Experiment, however, shows the reverse.

In table 2 is given a summary of the mean results obtained, illustrating how large this effect may be in an extreme case. The value of τ is calculated by the eq. 1.

TABLE 2.-Time of swing of rigid and flexible pendulums

Rigid		Flexible	
Position	Time	Position	Time
Up -----	0.997 81	Up -----	1.002 73
Down -----	<u>0.999 32</u>	Down -----	<u>1.000 63</u>
Mean -----	0.998 57	Mean -----	1.001 68
Difference of means -----0.003 11			
τ (rigid) = 1.000 48		τ flexible) = 0.999 01	
Difference ---- 0.001 47			

[828] It will be seen in this table that the unreduced times differ in the mean by 0.003 11 second. By applying eq 1 this difference does not disappear, but is reduced to about half its value.

Any resultant flexure effect, if at all appreciable, should be most in evidence in the most flexible pendulums. For this reason several pendulums of different flexibilities were used by us.

The Potsdam investigators developed, on theoretical considerations, a formula for flexure correction, which has been applied to our pendulums by Dr. H. L. Dryden of the National Bureau of Standards. The corrections in the value of g found by this formula are given in table 3 in parts by million.

TABLE 3.-Flexure corrections to the value of g

Pendulum number	Correction (units of the third decimal place)
2	-7
6	-5

4	-2
---	----

(h) AMPLITUDE

The theoretical correction for the effect of finite amplitude on the time of swing is given by the formula

$$T = T_0 \left(1 + \frac{\alpha^2}{16} + \dots \right) \dots \tag{8}$$

LeRolland⁸ found that, this formula does not give the entire effect of amplitude upon period, but that, generally speaking, the value of the time of swing at different amplitudes on being thus reduced to zero amplitude still showed a decrease with diminishing amplitude.

Our experience confirms that of LeRolland. The Potsdam observers, probably because of the very small amplitudes at which they worked (from 30' down), found that this effect was not strongly marked. The explanation of this discrepancy is doubtless ? with the effect of imperfection in the knife edge, which we have found to be the most serious difficulty with which we have had to deal, and which will be discussed at length in the next section. To avoid as far as possible the difficulty arising from the lack of applicability of eq 1 we finally limited the amplitude of swing of the pendulums to a maximum of about 30' and made observations down to about one-twentieth of this value.

(i) IMPERFECTIONS OF THE KNIFE-EDGE

Not all materials are suitable for knife-edges. The conditions under which a knife-edge is expected to stand up are extreme. The area of contact with the supporting plane is so small that the pressure may be of the order of several tons per square centimeter. Moreover, this pressure, as the pendulum swings, is exerted alternately on one side or the other of the knife-edge, an alternation repeated each [829] second for hours at a time, and a certain measure of fatigue of the edge (or the plane) may result. If under these conditions there should result a microscopic breakdown at any point of the edge, there may be a quite a noticeable effect on the motion of the pendulum.

On one occasion we were fortunate enough to observe what was undoubtedly the result of such a breakdown. The knife-edge, of stainless steel, was working against a plane of fused silica, and observations were being made for damping. The results in table 4 were obtained.

Table 4.—Observations for damping

Time	Amplitude mm	Ratio of amplitude s
10:53:30	31.69	-----
11:01:20	30.66	1.03
11:09:10	22.84	1.34
11:16:40	21.14	1.08

For the rest of the run (about 2 hours) the amplitude ratio varied between 1.08 and 1.10. It seems likely that at some time between and 11:01 and 11:09 a breakdown occurred, requiring for the moment an expenditure of energy on the part of the pendulum, and leaving the edge in a condition which gave rise to slightly more friction than the initial condition.

Several such instances were noticed with knife-edges of different materials. The breakdown must have been very small, as in no case could we be certain of detecting anything by microscopic examination.

It is easily seen that a knife-edge may, for this reason, be too sharp. In fact, on a mathematically sharp edge any finite weight, however small, would produce an infinite pressure and an instant breakdown.

This being the case, why not use a cylindrical rod instead of a knife-edge? Experiments of this nature were made some 50 years by the U. S. Coast and Geodetic Survey,⁹ but the results were not encouraging. Our experience has

⁸ Annales Phys. 22, p. 236 and following (1922).

⁹ U. S. Coast and Geodetic Survey, Special Publication no. 69, , Modern Methods for Measuring the Intensity of Gravity, page 14 (1921).

THE VALUE OF GRAVITY AT WASHINGTON

been similar. With too great a radius of curvature the damping becomes excessive, and the coincidence intervals show large variations.

In an instance of this, an agate knife-edge with a radius of about 10μ was placed in service with a pendulum containing stellite blocks. The results were at first quite concordant, but after about a month's daily use the values of g began to show a steady progression downwards. A remeasurement of the radius gave 18μ at one end of the edge and 69μ at the other.

An attempt was made to grind this edge to a uniform though larger radius by giving it a few strokes with a piece of thin aluminum foil charged with a fine abrasive, the strokes being directed perpendicular to the edge and the foil being held so as to form an inverted V over the edge. As a grinding operation, this may perhaps be called successful, as the radius afterward measured 195μ and 230μ at its ends. No apparent increase in width at the edge was noticeable.

The service results with this reground edge were very unsatisfactory. The damping was increased so that the duration of the swinging [830] of the pendulum was reduced from its normal value of 6 hours to $4\frac{1}{2}$ hours. In addition, the coincidence intervals varied greatly, fluctuating by as much as 1 minute in an interval of about 18 minutes, whereas with a sharp edge this variation was usually but a few seconds. A similar behavior was noticed when the pendulum rolled by means of its stellite block on a support made of 1-mm steel drill rod.

The disturbing effect of too blunt a support is probably due to adhesion at the surface of contact under the great pressure there. As the pendulum swings this adhesion is being continually formed and broken loose, and this latter operation requires an expenditure of force, which over a larger area may show a greater variation than with a sharper pendulum and a consequently a smaller area of contact.

But if a knife-edge may be too blunt as well as too sharp, what may be regarded as an optimum radius of curvatures? The answer to this must be expected to depend upon the material. Another agate edge, with a radius of about 35μ , gave what we considered that time satisfactory service for nearly 2 years, after which variable results began to make their appearance. On remeasurement the radius was then found to be 70μ at one end and 165μ at the other.

It is an obvious suggestion that the edge be kept sharp by regrinding. This is not a simple matter with agate, but is readily and quickly done with metallic edges. An edge of stellite with a radius 10μ was found to have increased to 15μ after 2 weeks' daily use. The procedure was then adopted of resharpening this edge after every three swings of the pendulum (in the up-down-up positions). By this procedure a radius of about 10μ could be maintained, and the departure from the mean of the values of g could be limited to a less than that attainable with any materials previously used.

The effects of use seem to be confined entirely to the knife-edge, the mirror surface of the optically flat planes showing no deterioration after several years in service.

LeRolland's experience¹⁰ was that, generally speaking, the harder materials used for the edge and plane introduced the least irregularity in its time of swing. This agrees with our experience. But is not the only quality necessary. A substance may be hard and very brittle, like fused silica, and an edge of this material showed itself to be inferior to one of agate, of the same chemical composition but of a different structure. A hard and tough material, such as stellite gave better results than agate.

Still better results were obtained by the use of a special steel known as Halcomb chrome steel, of the following analysis:

C=0.96%
Mn=0.35
P=0.014
S=0.017
Si=0.25
Cr=1.31

An edge made of this steel, oil hardened at 950° C, and used against a stellite plane, gave us our best results. The scleroscope hardness of this edge measured from 86 to 90, while the similar figure for the stellite plane was from 76 to 83. [831]

¹⁰ Annales Phys. 22, 244 (1922).

THE VALUE OF GRAVITY AT WASHINGTON

VI. RESULTS

The best results were obtained with a knife-edge of the chrome steel mentioned in the a last section. As will be seen by the tabulated results, the knife-edge appears to be a more important factor than the plane.

The measure of precision adopted was the average departure from the mean. This we consider preferable to the least square probable error of the mean. No matter how widely the individual results may vary, the probable error of the mean approaches zero as the number of observations increases indefinitely, and this may be misleading. On the other hand, as the number of observations is increased, the cumulative mean and the average departure from the mean both approach constancy. When this has been attained sufficiently for the purpose at hand there is nothing to be gained by taking additional observations.

In the following tables the results of our observations with the different combinations of planes and knife-edges are given in detail:

TABLE 5.—*Values of g*

Pendulum no. 3. Steel knife-edge. Stellite planes. Mass = 3.6 kg. Relative flexibility (see table 1) 0.61.
Length at 20 ° C:

October 11, 1934	997.760 mm	$h_1 = 695.3$ mm.
November 22, 1934	997.759 mm.	$h_2 = 302.5$ mm.
May 22, 1935	<u>997.761 mm</u>	
Mean	997.760 mm.	

Date, 1935	Pressure mm Hg	Tempera- ture ° C	Amplitude <i>Radians</i>	Time of swing (reduced to 20° C)		g	Cumulative mean
				Down	Up		
4-----	0.04-.06	22.6	0.0040-.0015	1.002 673 2			
6-----	.04-.06	22.2-22.4	.0046-.0009	1.002 504 2		980.090	980.090
7-----	.04-.08	22.5	.0045 .0007		1.002 672 4	092	091
8-----	.04-.08	22.2-22.4	.0050 .0009	1.002 502 6		091	091
9-----	.04-.08	22.7-22.4	.0045 .0009		1.002 670 4	088	090
10-----	.04-.08	22.3-22.6	.0061-.0011	1.002 504 8		083	089
11-----	.01-.07	22.6	.0040-.0014		1.002 667 7	082	088
13-----	.04-.10	22.3-22.5	.0059-.0006	1.002 503 6		083	087
14-----	.04-.08	22.8 22.7	.0045-.0009		1.002 666 4	086	086
15-----	.04-.06	21.5-22.7	.0051-.0009	1.002 501 5		089	087
16-----	.04.10	22.8-22.7	.0050-.0009		1.002 665 4	087	087
17-----	.04-.06	22.4-22.6	.0067-.0010	1.602 502 3		084	087
18-----	.03-.06	22.3-22.8	.0055-.0006		1.002 663 5	084	087
20-----	.04-.06	22.3-22.4	.0051-.0007	1.002 510 6		084	086
21-----	.04-.08	22.5-22.7	.0045-.0007		1.002 662 8		

Mean value of g	980.086	±0.003 avg departure
Correction for clock rate	<u>-0.001</u>	
	980.085	
Correction for flexure	<u>-0.005</u>	
g =	980.080	±0.003 avg departure

During this work with pendulum no. 3 the knife-edge gave such consistant results that no resharping was deemed necessary. Its radius of curvature, measured May 22, 1935, was 10 μ on one side of the center and 13 μ on the other. The knife-edge was then used with pendulum no. 4.

[832]

TABLE 6.—*Values of g*

Pendulum no. 4. Steel knife-edge. Stellite planes. Mass = 3.5 kg. Relative flexibility (see table 1) 0.28.
Length at 20° C:

May 23, 1935	998.879 mm.	$h_1 = 698.0$ mm.
June 17, 1935	<u>998.880 mm.</u>	$h_2 = 300.9$ mm.

THE VALUE OF GRAVITY AT WASHINGTON

Mean 998.879 mm.

	Pressure	Temperature	Amplitude	Times of swing (20° C)		g	Cumulative mean
				Down	Up		
May	mm Hg	° C:	Radians				
24 -----	0.04-.08	22.2-22.3	0.0080-.0007	-----	1.003 105 1	-----	-----
25 -----	.04-.07	22.5-.22.8	.0040-.0004	1.003 009 6	-----	980.085	980.085
27 -----	.04-.08	22.2-.22.5	.0073-.0006	-----	1.003 100 9	082	084
28 -----	.04-.08	22.7	.0045-.0004	1.003 009 3	-----	084	084
29 -----	.04-.08	22.5-22.6	.0084-.0006	-----	1.003 101 9	082	083
31 -----	.04-.08	22.5-22.8	.0085-.0005	1.003 010 8	-----	080	083
June							
3 -----	.04-.08	22.8	.0096-.0094	-----	1.003 101 6	082	083
4 -----	.04-.05	22.8	.0045-.0005	1.003 008 8	-----	082	082
5 -----	.04-.08	22.8-22.6	.0059-.0005	-----	1.003 096 3	081	082
6 -----	.04-.10	22.9-23.1	.0045-.0005	1.003 006 7	-----	082	082
10 -----	.05-.20	23.0	.0083-.0008	-----	1.003 098 0	085	083
12 -----	.03-.20	23.0-23.5	.0056-.0006	1.003 008 1	-----	079	-----
13 -----	.04-.09	23.4-23.7	.0050-.0005	-----	1.003 090 5	076	-----
14 -----	.03-.08	23.0-23.7	.0057-.0008	1.003 005 6	-----	067	-----
15 -----	.03-.06	23.5-23.6	.0050-.0007	-----	1.003 082 5	-----	-----

Mean value of g 980.083 ±0.0014 avg departure
 Correction for clock rate -0.001
 Correction for flexure 980.082
 -0.002
 g = 980.080 ±0.0014 avg departure

It will be noticed that while up to June 10 the values of g had maintained a fairly constant level, a marked decrease occurred after that date. Regarding this as probably caused by a breakdown of the knife-edge, its radius of curvature was remeasured on June 17. The results of the two sides were 11 μ and 13 μ. If the falling off of the value of g was caused by a breakdown of the knife-edge, such a deterioration must have been on a scale too small for measurement. The knife-edge was resharpened and remeasured, giving 4 μ at each end. This, by the way, is the value that we have found for the radius of curvature of a razor blade. The resharpened knife-edge was set up with pendulum no. 2, and it was interesting to see that the results for g returned to their normal value.

[833]

TABLE 7.—Values of g

Pendulum no. 2. Steel knife-edge. Stellite planes. Mass = 1.9 kg. Relative flexibility (see table 1) 0.89.
 Length at 20° C:

June 18, 1935 997.418 mm. $h_1 = 709.1$ mm.
 July 5, 1935 997.418 mm. $h_2 = 288.3$ mm.
 Mean 997.418 mm.

Date, 1935	Pressure	Temperature	Amplitude	Times of swing (20° C)		g	Cumulative mean
				Down	Up		
June	mm. Hg	° C	Radians				
19 -----	0.04	23.2-23.4	0.0062-.0008	-----	1.002 288 4	-----	-----
20 -----	0.03-.04	23.4	.0070-.0007	1.002 237 4	-----	980.084	980.08
21 -----	.03-.10	23.2-23.7	.0055-.0006	-----	1.002 279 1	084	084
22 -----	03-.04	23.6-23.8	.0045-.0009	1.002 233 8	-----	084	084
24 -----	03-.07	23.0-23.2	.0057-.0007	-----	1.002 275 0	092	086

THE VALUE OF GRAVITY AT WASHINGTON

25	-----	0.03	23.4-23.3	.0045-.0006	1.002 229	-----	093	087
					2			
26	-----	.03-.04	23.0	.0074-.0008	1.002 266	-----	087	087
					3			
27	-----	0.04	23.4 23.6	.0050-.0007	1.002 229 7	-----	079	086
28	-----	.03-.04	23.4	.0058-.0006	1.002 254	-----	073	085
					4			
29	-----	0.04	23.8	.0035-.0011	1.002 227 6	-----	081	084
1	-----	.03-.06	23.3-23.8	.0036-.0008	1.002 260 8	-----	088	085
2	-----	0.04	23.6-23.8	.0047-.0007	1.002 226 1	-----	089	085
3	-----	.03-.04	23.4-23.6	.0048-.0006	1.002 258 2	-----		

Mean value of g	980.085	± 0.0045 avg departure
Correction for clock rate	+0.001	
	<u>980.086</u>	
Correction for flexure	<u>-0.007</u>	
$g =$	980.079	± 0.0045 avg departure

TABLE 8.—*Values of g*

Pendulum no. 4. Steel knife-edge. Fused-silica planes. Mass = 3.6 kg. Relative flexibility (see table 1) 0.28.
Length at 20° C:

March 19, 1935 997.730 mm. $h_1 = 707.7$ mm.
 $h_2 = 291.0$ mm.

Date, 1935	Pressure mm Hg	Temper- ature ° C	Amplitude <i>Radians</i>	Times of swing (20° C)		g	Cumula- tive mean
				Down	Up		
April							
20	0.04-.06	21.9-21.8	0.0055-.0007	-----	1.002 077 3	-----	-----
22	.04-.06	21.6-21.8	.0062-.0005	1.002 912 2	-----	980.079	980.079
23	.04-.09	21.9-21.8	.0050-.0006	-----	1.002 976 4	079	079
24	.04-.06	21.7-22.0	.0063-.0005	1.002 912 4	-----	081	080
26	04-.06	22.0	.0059-.0006	-----	1.002 980 1	082	080
29	04-.06	22.0-22.2	.0070-.0004	1.002 913 2	-----	075	079
30	.04-.05	22.2-22.3	.0047-.0005	-----	1.002 972 3	071	078
May							
1	.04-.08	22.1 22.2	.0065-.0005	1.002 912 2	-----	078	078
2	04-.06	22.4-22.6	.0050-.0007	-----	1.002 979 2	081	078
3	.04-.07	22.3-22.4	.0061-.0004	1.002 913 1	-----	-----	-----

Mean value of g	980.078	± 0.003 avg departure
Correction for clock rate	-0.001	
	<u>980.077</u>	
Correction for flexure	<u>-0.002</u>	
$g =$	980.075	± 0.003 avg departure

[834] The results in tables 5 to 8 are the best that we have obtained, as measured by the small total spread of the individual values of g and the average departure from the mean. It should be noted that these results were all obtained with a chrome steel knife-edge and planes of stellite or fused silica. The results in the tables that follow were obtained with the same planes but different materials in the knife-edge, and it is of interest to see the marked deterioration in the quality of the results as compared with those in the preceding tables. These later results are not of importance as contributions to the final result, but are given because they show that the material of the knife-edge is of prime importance and that of the planes is secondary.

In some cases, as in tables 9 and 10, it was found necessary to sharpen the knife-edge (stellite) after every third determination of time of swing in order to keep the variation of the values of g within tolerable bounds. In such case the value of g was calculated from those times of swing which formed a triplet uninterrupted by a sharpening of the knife-edge.

In none of these tables have results been suppressed because of their wide departure from the mean.

TABLE 9. --*Values of g*

THE VALUE OF GRAVITY AT WASHINGTON

Pendulum no. 2. Stellite knife-edge. Stellite plane. Mass=1.9 kg. Relative flexibility (see table 1) 0.89.
Length at 20° C:

July 25, 1934	997.415 mm.	$h_1 = 709.1$ mm.
Oct. 8, 1934	<u>997.417 mm.</u>	$h_2 = 288.3$ mm.
Mean	997.416 mm.	

Date, 1934	Pressure mm Hg	Temper- ature ° C	Amplitude <i>Radians</i>	Times of swing (20° C)		g	Cumulative mean
				Down	Up		
Sept.							
7 -----	0.04	22.8-23.0	0.0069-.0009	-----	1.002 284 4	-----	-----
8 -----	.04	23.1	.0050-.0012	1.002 230 3	-----	980.100	980.100
10 -----	.04	22.8-23.0	.0071-.0007	-----	1.002 274 9	-----	-----
11 -----	.04	23.0	.0050-.0012	1.002 237 8	-----	-----	-----
12 -----	.04	22.9-23.0	.0057-.0011	-----	1.002 274 7	095	098
13 -----	.04	23.0	.0053-.0009	1.002 222 5	-----	-----	-----
15 -----	.04	23.1	.0054-.0011	-----	1.002 213 4	-----	-----
17 -----	.04	22.8	.0070-.0009	1.002 217 9	-----	081	092
18 -----	.04	22.8	.0050-.0010	-----	1.002 256 1	-----	-----
19 -----	.04	22.2-22.7	.0078-.0011	-----	1.002 278 2	-----	-----
20 -----	.04	22.9	.0050-.0012	1.002 232 3	-----	081	089
21 -----		22.7-22.8	.0059-.0008	-----	1.002 263 3	-----	-----
22 -----	.04	23.0-22.8	.0050-.0014	-----	1.002 776 6	-----	-----
24 -----	.04	22.8-22.9	.0059-.0009	1.002 231 3	-----	092	090
25 -----	.04	22.9 23.0	.0050-.0009	-----	1.002 273 9	-----	-----
26 -----	.04	22.8-23.0	.0069-.0015	-----	1.002 285 4	-----	-----
27 -----	.04	23.0	.0043-.0009	1.002 235 2	-----	084	089
28 -----	0.04-0.07	22.8	.0054-.0009	-----	1.002 275 3	-----	-----
29 -----	.04	23.0-23.2	.0062-.0010	-----	1.002 282 5	-----	-----
Oct.							
1 -----	.04	22.6-23.5	.0059-.0012	1.002 233 6	-----	082	088
2 -----	0.04-.0.07	22.5-22.7	.0057-.0008	-----	1.002 267 7	-----	-----
4 -----	.04	22.4-22.7	.0047-.0009	-----	1.002 278 7	-----	-----
5 -----	.04	22.2-22.5	.0058-.0008	1.002 236 3	-----	076	-----
6 -----	.04	22.5-22.7	.0046-.0012	-----	1.002 273 9	-----	-----

Mean value of g	980.086	±0.007 avg. departure
Correction for clock rate, zero		
Correction for flexure	<u>-0.005</u>	
$g =$	980.081	±0.007 avg. departure

THE VALUE OF GRAVITY AT WASHINGTON

[835]

TABLE 10.—*Values of g*

Pendulum no. 3. Stellite knife-edge. Stellite plane. Mass = 3.6 kg. Relative flexibility (see table 1) 0.61. Length at 20° C:

Oct. 11, 1934 997.760 mm. $h_1 = 695.3$ mm.
 Nov. 22, 1934 997.759 mm. $h_2 = 302.5$ mm.
 Adopted value 997.760 mm.

Date, 1934	Pressure	Temperature	Amplitude	Times of swing (20° C)		g	Cumulative mean
				Down	Up		
Oct.	mm Hg	° C	Radians				
12 -----	0.04	22.5-22.7	0.0063-.0012 -----	1.002 671 6	-----	-----	-----
15 -----	0.04-0.40	21.9-22.1	.0048-.0011	1.002 496 7	-----	980.110	980.110
16 -----	.04	22.2-22.1	.0050-.0011 -----	1.002 665 4	-----	-----	-----
17 -----	.04	22.1-22.3	.0062-.0013 -----	1.002 671 9	-----	-----	-----
18 -----	0.04-0.20	22.3-22.5	.0047-.0009	1.002 503 1	-----	088	099
19 -----	.04	22.0-22.3	.0055-.0011 -----	1.002 664 8	-----	-----	-----
22 -----	.04	22.2-22.4	.0058-.0012 -----	1.002 677 7	-----	-----	-----
23 -----	.04	22.3-22.5	.0054-.0010	1.001 506 4	-----	081	090
25 -----	0.04-0.05	22.6-22.7	.0052-.0011 -----	1.002 665 6	-----	-----	-----
26 -----	.04	22.5-22.7	.0049-.0012 -----	1.002 670 9	-----	-----	-----
27 -----	.04	22.5-22.8	.0069-.0013	1.002 506 7	-----	080	090
29 -----	.04	21.8-22.0	.0060-.0016 -----	1.002 672 3	-----	-----	-----
30 -----	0.03-0.04	22.0	.0058-.0007 -----	1.002 652 5	-----	-----	-----
31 -----	.04	22.0-22.2	.0067-.0014	1.002 503 8	-----	056	-----
Nov.							
1 -----	.04	22.1-22.2	.0050-.0012 -----	1.002 415 6	-----	-----	-----
2 -----	.01	22.0-22.1	.0055-.0011 -----	1.002 675 4	-----	-----	-----
5 -----	.04	22.0-22.1	.0055-.0012	1.002 507 0	-----	081	083
6 -----	.04	22.0-22.2	.0050-.0011	1.002 670 5	-----	-----	-----
7 -----	0.04-0.06	22.0-22.1	.0060-.0010 -----	1.002 677 5	-----	-----	-----
8 -----	.04	22.1-22.2	.0049-.0009	1.002 502 7	-----	098	085
9 -----	.04	22.0-22.2	.0054-.0012 -----	1.002 672 0	-----	-----	-----
12 -----	.04	21.2-21.8	.0056-.0012 -----	1.002 671 9	-----	-----	-----
14 -----	.04	21.3-21.4	.0056-.0011	1.002 506 4	-----	080	084
15 -----	.04	21.0-21.4	.0059-.0011 -----	1.002 670 4	-----	-----	-----
16 -----	.04	21.2-21.4	.0054-.0011 -----	1.002 664 3	-----	-----	-----
19 -----	.04	21.4-21.6	.0061-.0011	1.002 502 3	-----	067	082
20 -----	.04	21.6-21.9	.0057-.0012 -----	1.002 641 4	-----	-----	-----

Mean value of g 980.082 ±0.011 avg. departure
 Correction for clock rate, zero
 Correction for flexure -0.005
 g = 980.077 ±0.011 avg. departure

The results in table 12 are of interest only as an illustration of the inferiority of agate to chrome steel or even to stellite as a knife-edge material. The results of this series are better than those of a number of similar cases that might be cited. It will be noted that the results given in tables 11 and 12 were obtained within a month of each other, with the same pendulum, the only difference being the change from stellite to agate in the knife-edge.

THE VALUE OF GRAVITY AT WASHINGTON

[836]

TABLE 11.—*Values of g*

Pendulum no. 4. Stellite knife-edge. Stellite plane. Mass = 3.5 kg. Relative flexibility (see table 13) 0.28.
Length at 20° C:

July 28, 1933	998.818 mm.	$h_1 = 698.8$ mm.
Sept. 19, 1933	998.820 mm	
Jan. 22, 1934	998.817 mm.	$h_2 = 300.0$ mm.
June 1, 1934	<u>998.818 mm.</u>	
Adopted value	998.818 mm.	

Date, 1935	Pressure	Temper- ature	Amplitude	Times of swing (20° C)		g	Cumula- tive mean
				Down	Up		
May	mm Hg	° C	Radians				
9 -----	0.04	21.9-22.0	0.0040-.0004	-----	1.003 137 3	-----	-----
10 -----	.03	22.0-21.9	.0036-.0004	1.003 055 7	-----	980.089	980.089
11 -----	.04	22.4-22.1	.0039-.0004	-----	1.003 138 9	097	094
12 -----	0.03-0.04	21.8-21.9	.0041-.0004	1.003 001 7	-----	100	096
15 -----	0.06-0.03	22.1-22.2	.0043-.0004	-----	1.003 133 0	102	097
16 -----	.03	21.9	.0029-.0003	1.002 996 5	-----	111	100
17 -----	0.09-0.04	22.2-22.0	.0046-.0004	-----	1.003 129 7	111	102
19 -----	.04	22.2	0032-.3003	1.002 994 7	-----	102	102
21 -----	.03	22.0-22.1	.0044-.0003	-----	1.003 113 2	083	100
22 -----	.04	22.3	.0042-.0004	1.002 098 4	-----	077	098
23 -----	.03	22.1	.0039-.0003	-----	1.003 112 7	070	095
25 -----	.03	22.0-22.2	.0038-.0003	1.003 002 5	-----	069	092
26 -----	.04	22.4-22.1	.0044-.0004	-----	1.003 121 9	-----	-----

Mean value of g	980.092	±0.013 avg. departure
Correction for clock rate, zero		
Correction for flexure	<u>-0.002</u>	
$g =$	980.090	±0.013 avg. departure

TABLE 12.—*Values of g*

Pendulum no. 4. Agate knife-edge. Stellite planes. Mass = 3.5 kg. Relative flexibility (see table 1) 0.28.
Length at 20° C:

July 28, 1933	998.818 mm.	$h_1 = 698.8$ mm.
Sept. 19, 1933	998.820 mm.	
Jan. 22, 1934	998.817 mm.	$h_2 = 300.0$ mm.
June 1, 1934	<u>998.818 mm.</u>	
Adopted value	998.818 mm.	

Date, 1934	Pressure	Temper- ature	Amplitude	Times of swing (20° C)		g	Cumula- tive mean
				Down	Up		
May	mm Hg	° C	Radians				
29 -----	0.03-0.04	22.0-22.1	0.0048-.0003	1.002 913 2	-----	-----	-----
31 -----	.03-0.04	22.2-22.0	.0047-.0004	-----	1.002 913 5	980.078	980.078
June							
1 -----	0.04	22.1	.0039-.0004	1.002 911 5	-----	.084	081
2 -----	.03-0.04	22.1-22.4	.0042-.0004	-----	1.002 918 2	.085	082
4 -----	.03-0.04	22.0-22.5	.0042-.0003	1.002 912 6	-----	.098	076
5 -----	.04-0.05	22.2-22.5	.0043-.0004	-----	1.002 879 6	.?7	068
6 -----	.03-0.04	22.2-22.6	.0045-.0003	1.002 917 2	-----	.068	065
7 -----	0.04	22.8-22.7	.0040-.0004	-----	1.002 928 5	.089	068
8 -----	.03-0.04	22.2-22.5	.0047-.0004	-----	1.002 936 4	-----	-----
9 -----	0.04	22.8	.0042-.0005	1.002 917 6	-----	-----	-----
11 -----	.03-0.04	22.4-22.7	.0034-.0003	-----	1.002 946 8	.070	068
14 -----	.05-0.04	23.0-22.8	.0038-.0003	-----	1.002 872 0	-----	-----
15 -----	0.04	22.8	.0041-.0005	1.002 908 7	-----	-----	-----

THE VALUE OF GRAVITY AT WASHINGTON

Mean value of g	980.068	± 0.018 avg. departure
Correction for clock rate, zero		
Correction for flexure	<u>-0.002</u>	
$g =$	980.066	± 0.018 avg. departure

[837]

TABLE 13.—Summary of values of g

Pendulum number -----	2	3	4
Relative flexibility -----	0.89	0.61	0.28
Stellite plane -----	} 980.079 ± 0.0045	980.080 ± 0.003	980.080 ± 0.0014
Steel knife-edge -----			
Fused-silica plane -----	} -----		980.075 ± 0.003
Steel knife-edge -----			
Stellite plane -----	} 980.081 ± 0.007	980.077 ± 0.011	980.090 ± 0.013
Stellite knife-edge -----			
Stellite plane -----	}		980.066 ± 0.018
Agate knife-edge -----			

In connection with table 13 the following points may be noted:

1. The values of g obtained with the steel knife-edge (rows 1 and 2, table 13) show the greatest precision, the total spread of the individual values being 0.022 and the average departure from the mean less than 0.005.
2. A change in the material of the plane from stellite to fused silica (the knife-edge remaining the same) makes no change in the order of precision.
3. A change in the material of the knife-edge from steel to stellite (row 3) reduces the precision considerably, the average departure becoming of the order 0.01 and the spread of the individual values 0.055.
4. It will be noticed that in some cases (table 7) there is a tendency to a small but steady decrease in the times of swing, while the value of g remains fairly constant. This may be due to a slight progressive wear of the knife-edge, the effect nearly cancelling out in the application of eq 1.

The mean of the four best results (rows 1 and 2), weighted inversely as their average departures, is 980.079. If we include the three second-best results (row 3) the mean is 980.080 ± 0.003 ¹¹ But even with the four best results the spread of the individual values is 0.022 and the average departure of a set may be as much as 0.0045, it is our feeling that

$$g = 980.08 \text{ cm sec}^{-2} \pm 0.003 \text{ average departure}$$

goes as far in accuracy as is reasonably certain.

It should be noted that this result involves 70 single determinations of g .

The geographical coordinates of the gravity station, determined from information furnished by the U.S. Coast and Geodetic Survey, are as follows:

Latitude-----38°56' 30.143" N.

Longitude-----77°03' 56.893" W.

Elevation above sea level-----94.75 meters.

It may be of assistance in appraising the precision of the foregoing result to summarize the various minor sources of error for which no correction was deemed necessary. These are given in table 14.

¹¹ Our earlier results, obtained with knife-edges of agate and fused silica, are of too poor a grade to be considered for inclusion in the final result. Table 12 gives an example of perhaps the most presentable of these results.

[838]

TABLE 14—*Effect of minor sources of error*

Source	Estimated effect on g
Position of knife-edge on plane -----	Maximum not known. Minimum less than 1 part per million.
Parallelism of plane -----	1×10^{-8} .
Equality of T_1 and T_2 -----	$< 1.2 \times 10^{-7}$.
Center of gravity in line of supports -----	2×10^{-8} .
Departure of knife-edge from level -----	5×10^{-7} .
Error of standard scale -----	$\leq 1 \times 10^{-6}$.
Elastic deformation of pendulum under own weight ----	$\leq 1 \times 10^{-6}$.
-	
Microscope error -----	$< 1 \times 10^{-6}$.
Clock-rate variation -----	$<< 1 \times 10^{-6}$.
Motion of support -----	5×10^{-7} .
Damping -----	2×10^{-9} .
Compressibility of pendulum -----	5×10^{-7} .

VII. THE POTSDAM DETERMINATION

The value of g in the pendulum room at the National Bureau Standards, as deduced from the direct connection made with Potsdam to the pendulum room in 1933 by Lt. Brown of the U. S. Coast Geodetic Survey, is 980.100 The value adopted as the result of absolute measurement, is 980.08. The difference, 2 parts in 100,000 suggests that an examination of possible causes is desirable. In connection it should be remembered that the various connections between Washington and Potsdam have differed by as much as 9 parts in a million.

The precision claimed in the Potsdam report is ± 0.003 . It is noted that this is a least, square probable error, and corresponds much larger average departure front the mean

The Potsdam results are tabulated and discussed as the length of equivalent simple seconds pendulum, and reduced to the value of g only at the end of the report after all reductions had been made. We shall find it convenient, however, to quote the Potsdam results translated into equivalent values of g at the National Bureau of Standards in Washington, using for this purpose the difference found by Lt. Brown:

$$\text{Potsdam} - \text{Washington} = + 1.174.$$

The Potsdam results fall into two classes, those obtained pendulums carrying two knife-edges and those. given by pendulums provided with two planes. In the first class there are given separate values and in the second class 84. The maximum, and mean values are given in table 15.

TABLE 15.—*Values of g at Washington derived from Potsdam*

	Two knife-edges	Two planes
Maximum -----	980.180	980.136
Mean -----	980.090	980.072
Minimum -----	980.008	979.983
Total spread -----	0.172	0.153
Average departure from mean -----	0.017	0.026
Number of individual results -----	108	84

[839] Different methods of classifying and weighting the subgroups of individual observations give mean values ranging from 980.082 to 980.089.

We may direct attention to the following points of interest in the above table.

1. The spread of the separate values is nearly 3 times that (0.055) obtained in the less accurate sets of our work. The average departure from the mean is also considerably greater than ours.

2. The 70 single observations in our work will therefore compare favorably with the greater number of observations of less precision in the Potsdam report.

THE VALUE OF GRAVITY AT WASHINGTON

3. The weighted mean of the Potsdam observations, obtained as above, is in reasonable agreement with our adopted result.

It remains to be explained how this Potsdam experimental mean was increased to give 980.100 at Washington.

It was recognized by the Potsdam observers that knife-edge errors played a large part in absolute-gravity work. A considerable portion of the Potsdam report is devoted to an attempt to evaluate these errors on the basis of variations in the results given by the different pendulums employed. As a result of this evaluation the value of g was raised to 980.100 (at Washington). This process of correction appears to amount for the most part to an extrapolation of the results obtained with the different pendulums to that which would correspond to a pendulum of zero mass. The masses of the pendulums ranged from 2.86 to 6.23 kg, and in the extrapolation referred to the lightest pendulum seems to have had a disproportionate influence. Our results do not indicate a variation with mass, and therefore no such adjustment has been made.

WASHINGTON, July 29, 1935.