

# WIDE-RANGE MICROWAVE FREQUENCY SYNTHESIS USING AN OFFSET PASSIVE RESONATOR<sup>1</sup>

D. A. HOWE\*, A. HATI†, C. NELSON\*, F. L. WALLS#,  
J. F. GARCIA NAVA#, and A. SENGUPTA\*\*

\* National Institute of Standards & Technology, Boulder, CO, USA

+ Guest Researcher, Burdwan University, Calcutta, India

# Total Frequency, Boulder CO, USA

\*\* Guest Researcher, National Physical Laboratory, New Delhi, India

## Abstract

*We demonstrate a technique to obtain wide synthesized tunability from the local oscillator (LO) of a low-noise, fixed-frequency microwave reference whose noise is suppressed by a high-Q cavity discriminator operated in a passive mode. The results show that under proper conditions the phase-locked LO's phase noise in the tunable approach presented here and that for the normal fixed-frequency mode are substantially the same. Thus the need for a number of filters, mixers, and amplifiers necessary for an additional synthesizer is eliminated.*

## I. INTRODUCTION

A high-Q microwave cavity has often been used to improve the spectral purity of microwave oscillators. For this purpose the cavity is used as a frequency discriminator to phase-lock an external dielectric resonant oscillator (DRO) [1, 2]. Alternatively, the high-Q cavity can serve both as the band-pass element in an active oscillator as well as the discriminator for reduction of phase noise [3]. In either case, the result is a fixed-frequency output at the resonance frequency of the cavity. A small amount of frequency tuning is possible by fine-tuning the cavity resonance frequency but is limited usually to only about a few megahertz at X-band for a given setup. If a different frequency is needed, then one has to use a different cavity and the rest of the locking system. Thus the inability to widely tune the output frequency turns out to be one of the major limitations of this approach. Noise performance is often sacrificed when tunability takes priority.

We have designed and tested an approach that involves offsetting the frequency of the DRO by mixing its output with an oscillating signal having a low frequency  $\Delta f$  in a single-side-band (SSB) mixer, before feeding it to the microwave cavity. Thus in the locked condition, the DRO output has a frequency offset from the cavity frequency by  $\Delta f$ . Since the frequency offset is comparatively low, it is possible to synthesize it with a low phase noise compared to that of the X-band DRO frequency, and mixing of the frequency offset with the DRO frequency does not degrade its phase noise. Another major advantage of this scheme is that the cavity acts as a high-Q filter to eliminate the unwanted sidebands arising out of the mixing process. The results of the experiment demonstrate that the phase noise in our offset locking scheme is indeed not noticeably degraded. Our results are perhaps the first to show a scheme for a wide-range frequency synthesizer, which also achieves the low phase noise levels normally realized by a fixed-frequency cavity-locking approach.

## II. CONVENTIONAL FIXED-FREQUENCY APPROACH

In the basic fixed-frequency reference (later to be converted to a synthesizer) we use a TE<sub>023</sub> mode in a cavity whose interior surface is machined and polished. The cavity dimensions are such that the desired mode has an unloaded Q of 60,000 and a frequency of 10.6 GHz. This is

---

<sup>1</sup> Work of an agency of the US Government. Not subject to copyright.

used as a frequency discriminator in a wide-band loop (bandwidth of approximately 1 MHz), which controls the local oscillator (LO) frequency generated by a DRO. The scheme is shown in figure 1 along with the phase noise measurement system that uses a 10 GHz reference from a low-noise sapphire-loaded cavity oscillator (SLCO) and 600 MHz from a low-noise oscillator and multiplier/mixer (shown in figure 2). The frequency discrimination uses a delay-line bridge, where the phase error about the fixed cavity's center frequency becomes a voltage error feeding an integrator-frequency control for the DRO signal. Partial carrier-suppression occurs because a reflected signal from the cavity is combined through a circulator with the incident signal. The incident 10.6 GHz (carrier + noise) signal to the cavity can be made arbitrarily large (+24 dBm in this case), so that it overcomes the mixer noise of the cavity/discriminator setup [1,3,4].

For initial phase noise measurements and to establish the baseline performance of the non-synthesized 10.6 GHz source, we configured a system to use our low-noise 10 GHz SLCO [5]. Its signal is first mixed with the 10.6 GHz source, regarded as the device under test, or DUT. The difference frequency of 600 MHz is subsequently mixed with a low-noise 600 MHz source, which is shown schematically in figure 2. Thus there are two oscillators comprising the reference for the measurement. Phase noise is determined by measuring phase fluctuations relative to long-term  $90^\circ$  average phase difference as a condition of lock between this pair of reference oscillators comprising 10.6 GHz and the 10.6 GHz DUT. The measurement-system phase-locked loop (PLL) is shown in figure 3 and configured to correct the frequency of the 10 GHz SLCO. Short-term phase fluctuations (those shorter than the response time of the PLL) are readily measured as voltage fluctuations out of the 600 MHz mixer on a conventional spectrum analyzer [6,7]. A noise standard can be inserted into the DUT's signal path to calibrate the sensitivity of the measurement system [8].

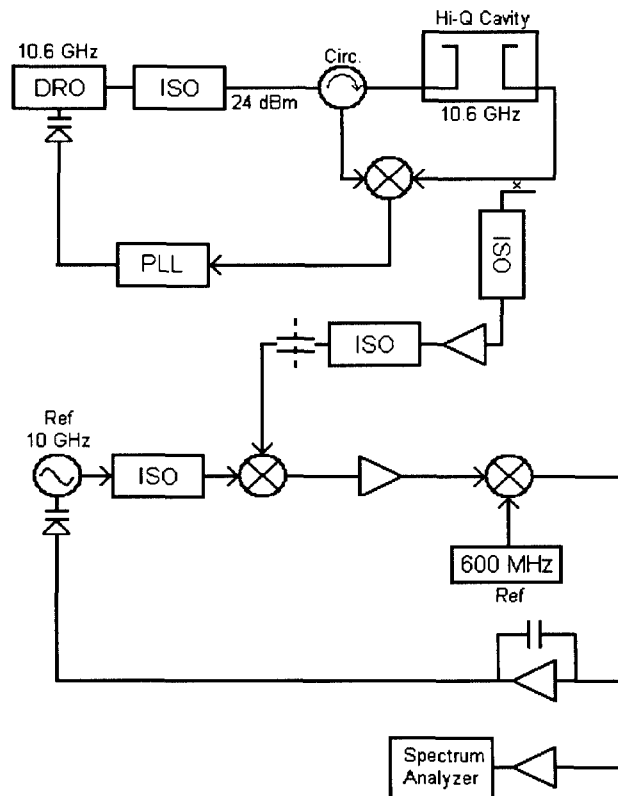

Figure 1: The non-synthesized, fixed-frequency microwave reference at 10.6 GHz is shown at the top. At the bottom is the scheme for the oscillator PM noise measurement. DRO = dielectric resonant oscillator; ISO = isolator; PLL = phase-locked loop.

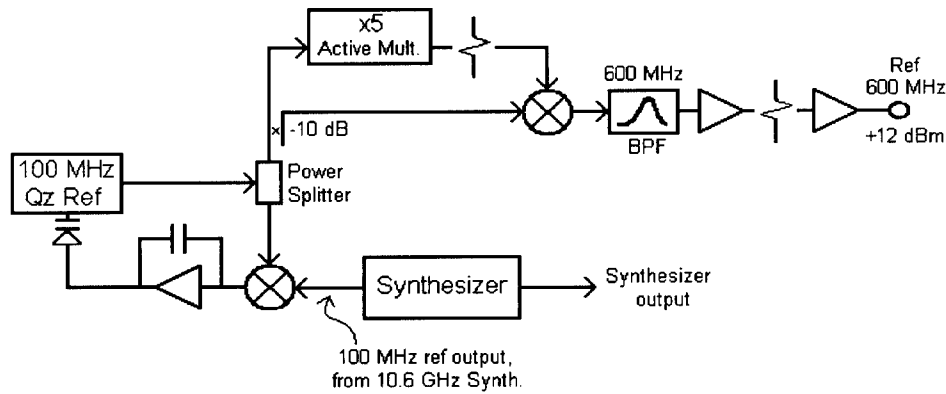

Figure 2: 600 MHz source used for the measurement system in figure 1. BPF = bandpass filter.

### III. OFFSET FREQUENCY APPROACH

The DRO frequency of figure 1 is offset by 1 to 10 MHz through a SSB mixer as shown in figure 3. Thus, the DRO frequency plus or minus an offset  $\Delta f$  (“IF” designated in figure 3) from a clean source generates  $f_{LO} \pm \Delta f$  (throughout this paper, “ $\pm$ ” means “plus or minus”) by means of a SSB mixer. Placement of the  $f_{LO} \pm \Delta f$  signal ahead of the hi-Q cavity is the important novelty of the synthesizer approach in this paper. In a locked condition, the cavity frequency ( $f_{CAV}$ ) equals  $f_{LO} \pm \Delta f$ , and it follows that  $f_{LO} = f_{CAV} \pm \Delta f$ , where the frequency offset and increments of

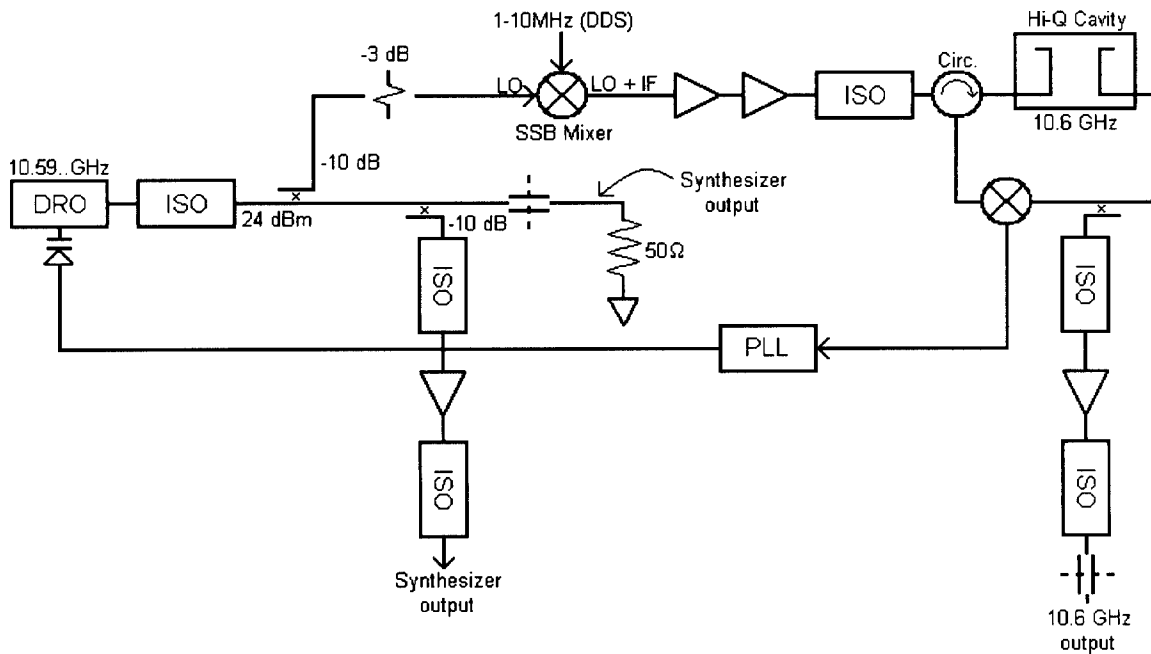

Figure 3: Frequency synthesis with offset from resonator frequency. The frequency of the DRO is offset by 1 to 10 MHz by a synthesized IF frequency generated from a direct digital synthesizer (DDS) whose comparatively low frequency occurs before the hi-Q cavity discriminator, and thus the DRO’s frequency is tunable by the DDS.

$\Delta f = f_{IF}$  are determined by the range and resolution of a commercial direct digital synthesizer (DDS). While the scheme of the basic non-synthesized (fixed-frequency) reference described in section II permits driving the hi-Q cavity discriminator at high power (see figure 1), the SSB mixer that provides the “LO + IF” signal in figure 3 has a power limitation of about +14 dBm. Therefore, the DRO signal is attenuated from its normal +24 dBm level to +11 dBm with an adjustable DDS level up to +3 dBm. The LO + IF signal is amplified to approximately its previous normal level of +24 dBm, after cable, mixer, and isolator losses.

#### IV. PM MEASUREMENT METHOD AND DATA

To satisfy the need for measuring sufficiently low phase noise with the same wide tunability, we again used our fixed-frequency 10 GHz SLCO and 600 MHz reference shown in figure 2. Ahead of the PLL shown in figure 1, bottom, we inserted an additional reference offset of 5 to 10 MHz between the output of the 600 MHz mixer and the input to the PLL circuit, as shown in figure 4. This permitted the measurement of the phase noise of the 10.6 GHz synthesized signal at various frequencies while retaining essentially the same low measurement-system noise of the earlier fixed-frequency setup shown in figure 1.

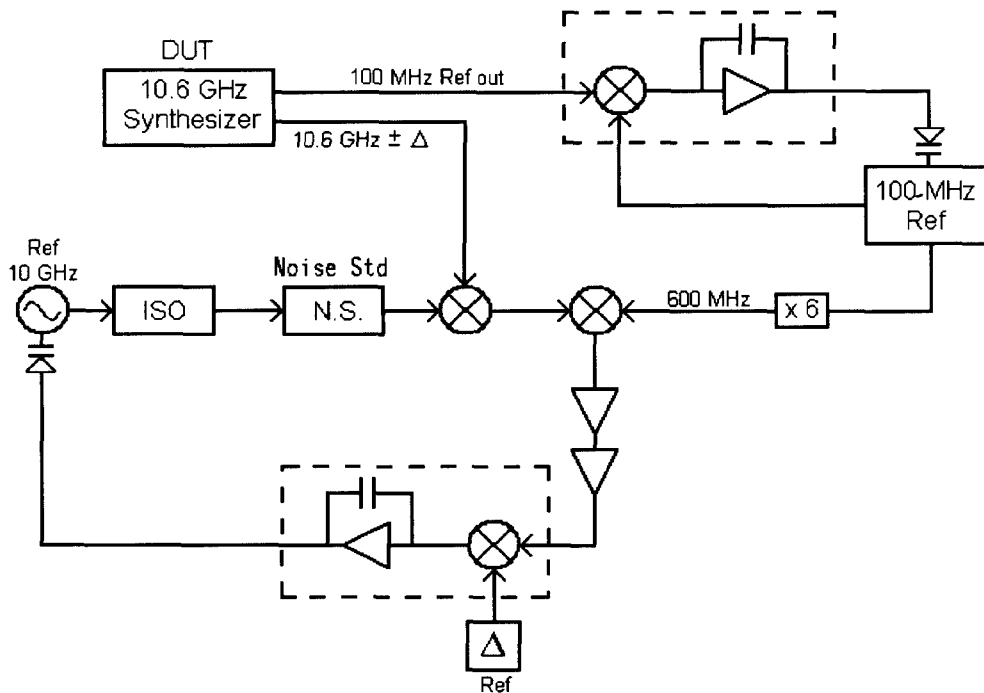

Figure 4: Scheme for measuring phase noise of the 10.6 GHz synthesized signal at various offset frequencies.

Figure 5 show plots of  $\mathcal{L}(f)$  in which one can see a comparison between synthesized and fixed-frequency (non-synthesized) phase noises of the 10.6 GHz source. The non-synthesized signal is one that uses the output of the original 10.6 GHz source as described in section II. In particular, the directional coupler, SSB mixer, amplifiers, DDS, and isolator are not used in the non-synthesized approach, while they are used in the synthesized approach as described in section III and shown in figure 3 with a comparison of phase noise shown in figure 5. The noise floor of the measurement system of figure 4 is also indicated and is sufficiently low that it does not contribute to the measurement results of the DUT.

If the dominant source of the noise is the LO, and the added synthesizer noise from the offset-frequency DDS, amplifiers, isolator, and SSB mixer are kept below the noise using the non-synthesized approach, then the phase noise of the synthesized approach is essentially the same as with the non-synthesized approach. An important finding is that the AM (amplitude modulation) noise of the offset signal must also be as low as or lower than its PM (phase modulation) noise. We have found that the SSB mixer converts substantially all AM noise to PM noise, so it is crucial to have both AM and PM noise at sufficiently low levels.

### 10.6 GHz Synthesizer Measurements

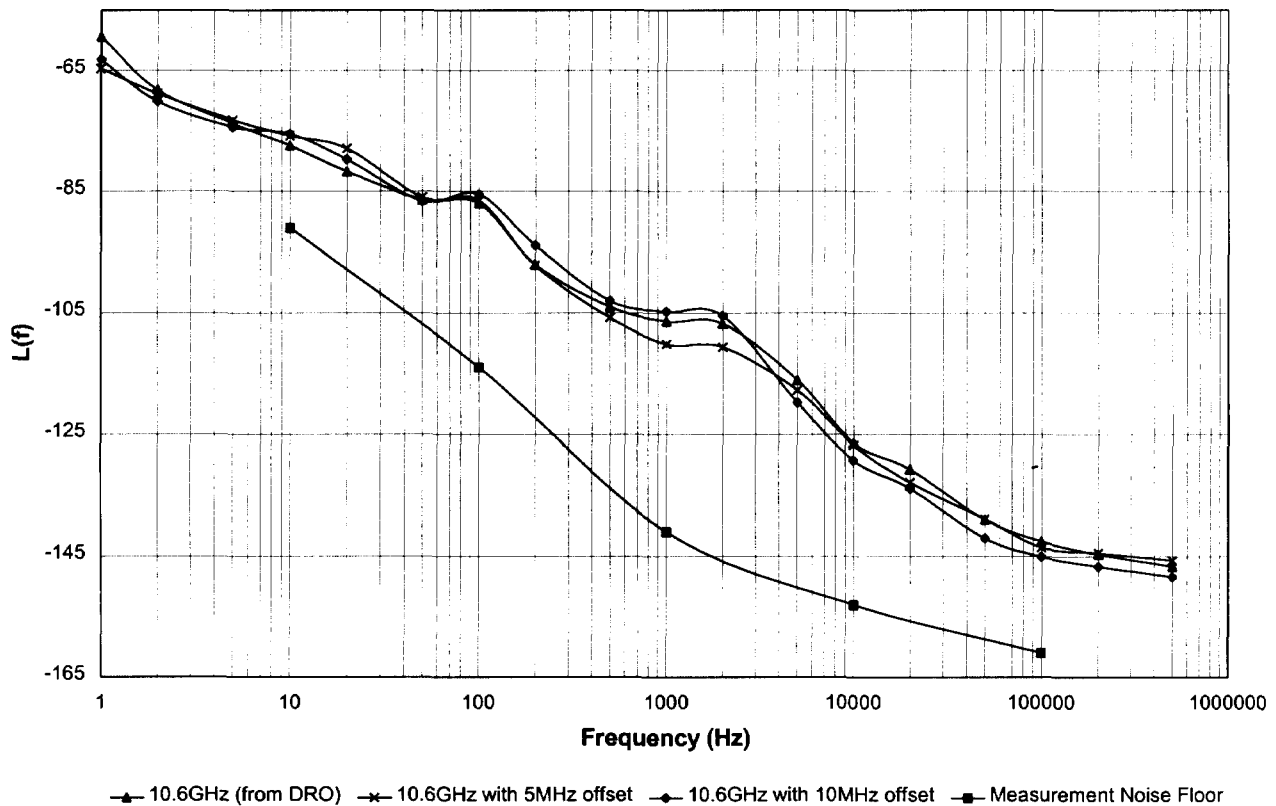

Figure 5: Comparison of noise at offsets = 0 (that is, with no SSB mix), 5, and 10 MHz. Phase noise of synthesized approach (5 and 10 MHz offsets) and non-synthesized approach (0 offset best performance, see section II) approaches are substantially the same.

### V. CONCLUSION

We have shown that a microwave local oscillator can be locked at an offset frequency to a fixed-frequency passive high-Q resonator while still exploiting the noise suppression offered by the resonator. We have constructed a low-noise system for measuring phase noise with wide tuning ability using a fixed-frequency 10 GHz SLCO and measured the PM noise of a 10.6 GHz synthesized signal at various frequencies. We find that the synthesizer PM noise can be as good as the non-synthesized, fixed-frequency PM noise using the same hardware, as long as the AM noise of the offset DDS synthesizer is below its PM noise, probably because of the wide-band SSB mixer that generates the offset. A coarse frequency preset of the LO, which is a voltage-tunable DRO, is useful to prevent false lock to the opposite sideband when a low offset frequency is used.

The broadband noise suppression offered by the hi-Q cavity is highly effective in lowering the output noise of the tunable reference as long as the dominant source of the noise is the LO and added synthesizer noise from the DDS, amplifiers, and SSB mixer are kept below the noise of the cavity/discriminator.

## References

- [1] F.L. Walls, C.M. Felton, T.D. Martin, "High Spectral Purity X-band Source," Proc. 44<sup>th</sup> Annual Frequency Control Symposium, pp. 542-548, May, 1990.
- [2] V.F. Kroupa, "Frequency Synthesis: Theory, design and Applications", John Wiley & Sons, pp 62-63, 1973
- [3] E.N. Ivanov, M.E. Tobar, R.A. Woode, "Application of Interferometric Signal Processing to Phase-Noise Reduction in Microwave Oscillators," IEEE Trans. On Microwave Theory and Techniques, vol. 46, no. 10, pp. 1537-1545, Oct. 1998.
- [4] J.K.A. Everard, "Ultra Low Noise Microwave Oscillators with Low Residual Flicker Noise," IEEE International Microwave Symposium, pp. 693-696, Orlando, FL, May 16-20, 1995.
- [5] M.E. Tobar, E.N. Ivanov, R.A. Woode, J.H. Searls, "Low noise microwave oscillators based on high-Q temperature stabilized sapphire resonators," Proc. 1994 IEEE International Frequency Control Symposium, pp. 433-440, May, 1994.
- [6] D.B. Sullivan, D.W. Allan, D.A. Howe, and F.L. Walls (Editors), "Characterization of Clocks and Oscillators", National Institute of Standards and Technology Technical Note 1337, Section A-6, March 1990.
- [7] E.S. Ferre-Pikal, J.R. Vig, et al., "IEEE 1139-1999: Standard Definitions of Physical Quantities for Fundamental Frequency and Time Metrology--Random Instabilities," Institute of Electrical Engineers, Inc., New York, NY 10017, USA.
- [8] F.L. Walls, "Reducing the errors, complexity and measurement time for PM noise measurements," Proc. 1993 IEEE International Frequency Control Symposium, pp. 289-297, May, 1993.