

A UNITED STATES
DEPARTMENT OF
COMMERCE
PUBLICATION



NBS TECHNICAL NOTE 611

U. S.
DEPARTMENT
OF
COMMERCE

National
Bureau
of
Standards

**NBS Frequency-Time
Broadcast Station WWV,
Fort Collins, Colorado**

NATIONAL BUREAU OF STANDARDS

The National Bureau of Standards¹ was established by an act of Congress March 3, 1901. The Bureau's overall goal is to strengthen and advance the Nation's science and technology and facilitate their effective application for public benefit. To this end, the Bureau conducts research and provides: (1) a basis for the Nation's physical measurement system, (2) scientific and technological services for industry and government, (3) a technical basis for equity in trade, and (4) technical services to promote public safety. The Bureau consists of the Institute for Basic Standards, the Institute for Materials Research, the Institute for Applied Technology, the Center for Computer Sciences and Technology, and the Office for Information Programs.

THE INSTITUTE FOR BASIC STANDARDS provides the central basis within the United States of a complete and consistent system of physical measurement; coordinates that system with measurement systems of other nations; and furnishes essential services leading to accurate and uniform physical measurements throughout the Nation's scientific community, industry, and commerce. The Institute consists of a Center for Radiation Research, an Office of Measurement Services and the following divisions:

Applied Mathematics—Electricity—Heat—Mechanics—Optical Physics—Linac Radiation²—Nuclear Radiation²—Applied Radiation²—Quantum Electronics³—Electromagnetics³—Time and Frequency³—Laboratory Astrophysics³—Cryogenics³.

THE INSTITUTE FOR MATERIALS RESEARCH conducts materials research leading to improved methods of measurement, standards, and data on the properties of well-characterized materials needed by industry, commerce, educational institutions, and Government; provides advisory and research services to other Government agencies; and develops, produces, and distributes standard reference materials. The Institute consists of the Office of Standard Reference Materials and the following divisions:

Analytical Chemistry—Polymers—Metallurgy—Inorganic Materials—Reactor Radiation—Physical Chemistry.

THE INSTITUTE FOR APPLIED TECHNOLOGY provides technical services to promote the use of available technology and to facilitate technological innovation in industry and Government; cooperates with public and private organizations leading to the development of technological standards (including mandatory safety standards), codes and methods of test; and provides technical advice and services to Government agencies upon request. The Institute also monitors NBS engineering standards activities and provides liaison between NBS and national and international engineering standards bodies. The Institute consists of the following technical divisions and offices:

Engineering Standards Services—Weights and Measures—Flammable Fabrics—Invention and Innovation—Vehicle Systems Research—Product Evaluation Technology—Building Research—Electronic Technology—Technical Analysis—Measurement Engineering.

THE CENTER FOR COMPUTER SCIENCES AND TECHNOLOGY conducts research and provides technical services designed to aid Government agencies in improving cost effectiveness in the conduct of their programs through the selection, acquisition, and effective utilization of automatic data processing equipment; and serves as the principal focus within the executive branch for the development of Federal standards for automatic data processing equipment, techniques, and computer languages. The Center consists of the following offices and divisions:

Information Processing Standards—Computer Information—Computer Services—Systems Development—Information Processing Technology.

THE OFFICE FOR INFORMATION PROGRAMS promotes optimum dissemination and accessibility of scientific information generated within NBS and other agencies of the Federal Government; promotes the development of the National Standard Reference Data System and a system of information analysis centers dealing with the broader aspects of the National Measurement System; provides appropriate services to ensure that the NBS staff has optimum accessibility to the scientific information of the world, and directs the public information activities of the Bureau. The Office consists of the following organizational units:

Office of Standard Reference Data—Office of Technical Information and Publications—Library—Office of Public Information—Office of International Relations.

¹ Headquarters and Laboratories at Gaithersburg, Maryland, unless otherwise noted; mailing address Washington, D.C. 20234.

² Part of the Center for Radiation Research.

³ Located at Boulder, Colorado 80302.

UNITED STATES DEPARTMENT OF COMMERCE
Maurice H. Stans, Secretary
NATIONAL BUREAU OF STANDARDS ● Lewis M. Branscomb, Director



TECHNICAL NOTE 611

ISSUED OCTOBER 1971

Nat. Bur. Stand. (U.S.), Tech. Note 611, 29 pages (Oct. 1971)
CODEN: NBTNA

NBS Frequency-Time Broadcast Station WWV, Fort Collins, Colorado

Peter P. Viezbicke

Time and Frequency Division
Institute for Basic Standards
National Bureau of Standards
Boulder, Colorado 80302



NBS Technical Notes are designed to supplement the Bureau's regular publications program. They provide a means for making available scientific data that are of transient or limited interest. Technical Notes may be listed or referred to in the open literature.

CONTENTS

	Page
1. INTRODUCTION	1
2. SITE DESCRIPTION AND SURVEY	2
3. BUILDING DESIGN	2
4. SYSTEM DESIGN	11
4.1 Antenna Design	11
4.2 Frequency-Time Code and Control Systems	14
4.3 Transmitters	23
4.4 Monitoring System	24
5. SUMMARY	24
6. ACKNOWLEDGMENTS	25
7. REFERENCES	25

LIST OF FIGURES

	Page
Figure 1. Map showing location of site with respect to Fort Collins, Boulder, and Denver.	3
Figure 2. Contour map of WWV and WWVB/WWVL showing location of transmitter buildings and antennas.	4
Figure 3. Photograph of the NBS Fort Collins field stations.	5
Figure 4. Photograph of the WWV transmitter building.	7
Figure 5. Floor plan of the WWV transmitter building.	8
Figure 6. View of the transmitters along the south corridor of the building.	9
Figure 7. The south corridor of the building behind the transmitters, showing overhead cable trays, power line disconnect switch, and air ducts to the transmitters.	10
Figure 8. Graph showing theoretical coverage of WWV for the Western Hemisphere during the summer at high solar activity.	12
Figure 9. Measured radiation pattern of the 15 MHz WWV vertical dipole. Deflection proportional to field strength normalized to a distance of 1 mile (1.6 km) from the antenna.	13
Figure 10. Vertical radiation pattern of a vertical half-wave dipole located $3/8 \lambda$ above good ground. The frequency is 10 MHz.	15
Figure 11. Design details of the WWV antennas.	16
Figure 12. Photograph of the 25 MHz dipole antenna.	17
Figure 13. A view of one of the 2.5 - 25 MHz standby antennas.	18
Figure 14. Block diagram of control equipment.	19
Figure 15. Photograph of control equipment.	20
Figure 16. Block diagram of the 10 kW transmitter.	21
Figure 17. Block diagram of the 40 kW transmitter.	22

NBS FREQUENCY-TIME BROADCAST STATION WWV,
FORT COLLINS, COLORADO

Peter P. Viezbicke

This report describes the design and construction of the National Bureau of Standards frequency-time broadcast station located at Fort Collins, Colorado. The principal function of the station is to broadcast basic standards of frequency and time signals on frequencies of 2.5, 5, 10, 15, 20, and 25 MHz. These high frequency transmissions, which can be received on the simplest of equipment, provide the necessary accuracy required to fulfill some of the needs of industry, Government, and the public. The technical and administrative supervision of the station is under the Time and Frequency Division, Frequency-Time Broadcast Services Section, National Bureau of Standards, Boulder, Colorado.

Key words: High frequency; standard radio frequencies; time-frequency broadcasts; time signals; WWV.

1. INTRODUCTION

At 0000 hours GMT December 1, 1966, WWV transmissions were transferred to and placed into operation at Fort Collins, Colorado. The old and obsolescent Greenbelt, Maryland facility was replaced in its entirety at the Fort Collins site. Since its rebuilding in 1943, WWV-Greenbelt had made the basic standard of frequency-time service available continuously to its users through HF broadcast transmissions on frequencies in the 2.5 to 25 MHz range [1, 2]. Throughout the years, however, equipment became old, faulty, and continually in need of repair. In order to continue this most essential and widely-used service, Congress appropriated \$970,000 in 1962 to relocate the station in the west-central part of the continental United States. Funds became available the latter part of fiscal year 1964, the relocation program commenced in 1965, and WWV began initial broadcasts in December 1966. The new facility, located on a site near the present WWVB/WWVL station, not only provides a more reliable service throughout most of the country, but it is also in close

proximity to the Boulder Laboratories, which provides its technical and administrative supervision.

This report describes the new WWV Fort Collins HF broadcast installation. Its scope includes site description, building design, system design, antenna design, frequency-time code and control systems, transmitter characteristics, and monitoring system.

2. SITE DESCRIPTION AND SURVEY

The NBS transmitter site is located approximately seven miles (11.3 km) north of Fort Collins on Highway No. 1 enroute to Wellington, Colorado. It covers an area of approximately 380 acres ($1.537 \times 10^6 \text{ m}^2$) and is located in Section 7, Township 8 North, Range 68 W of the South P.M., Larimer County, Colorado. Figure 1 gives a map of the site detailing the locations of WWVB/WWVL and WWV facilities and arrangement of the antennas is presented in figure 2. An aerial view of the Fort Collins site is shown in figure 3.

WWV operates with six antennas which are arranged and located in an arc of a circle on the ridge of a hill. The terrain in all but the southerly direction of propagation slopes downward in the immediate vicinity of the antennas. Although declivity in the southerly direction is not as pronounced as in the other directions, omnidirectional low-angle radiation does result and is used advantageously due to these natural terrain features as well as the electrical soil properties of the area. The relatively high soil conductivity of 29 millimhos/meter at the site is attributed in part to the high saline content of the soil. This region has been under irrigation for a number of years which probably explains the high concentration of salt deposits and the resulting high conductivity.

The building, constructed into the side of a hill, is located at a lower elevation than the antennas. This location was selected to prevent objectionable reflections that might cause deleterious effects on the radiation characteristics of the antennas.

3. BUILDING DESIGN

The tee-shaped transmitter building is of cement block construction, air cooled, and has a total area of 6880 ft² (639 m²); it consists of the following specific areas: The transmitter room occupies an

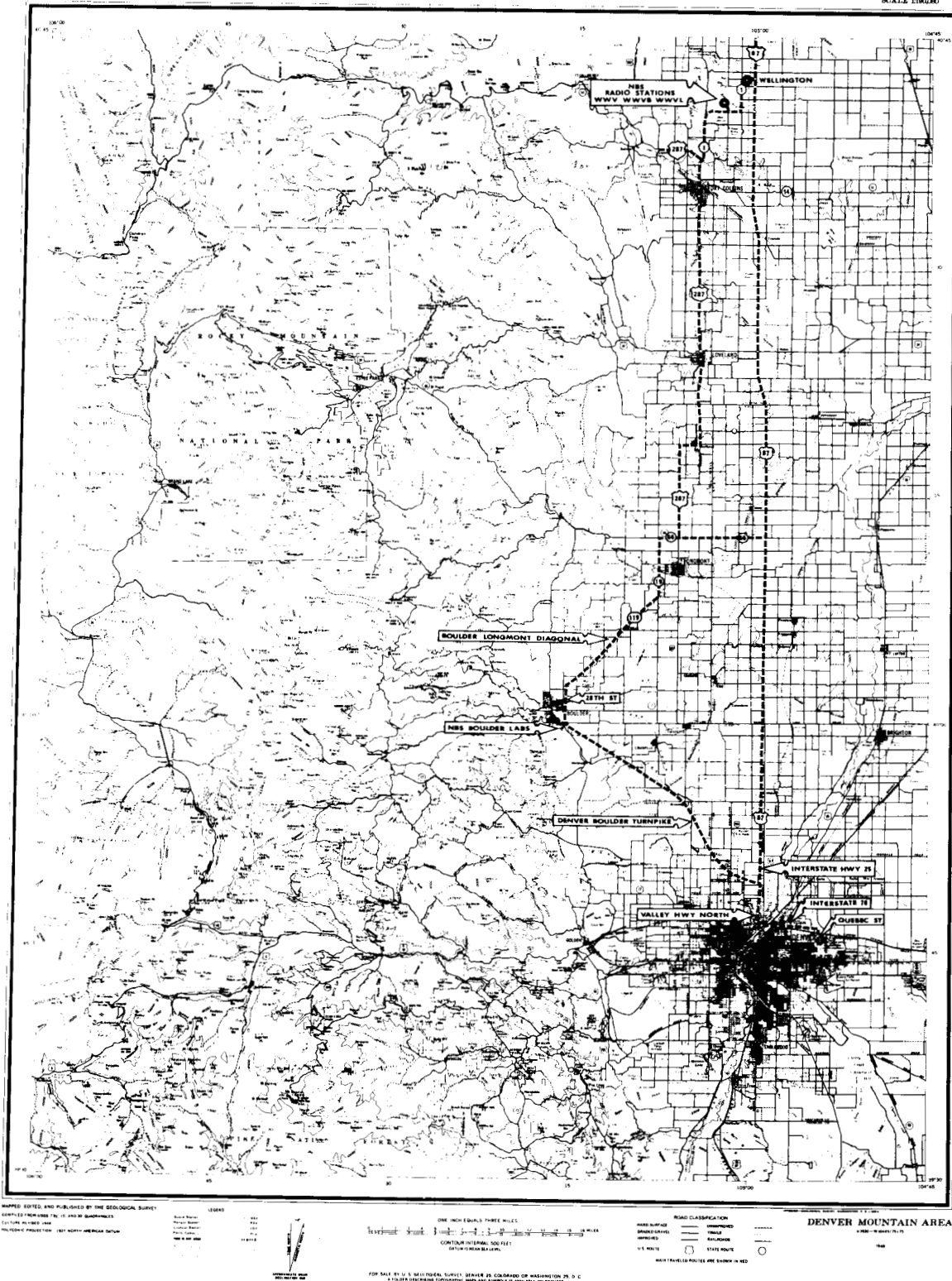

Figure 1. Map showing location of site with respect to Fort Collins, Boulder, and Denver. (To convert to kilometers, multiply by 1.6.)



Figure 3. Photograph of the NBS Fort Collins field stations.

area of 3067 ft² (285 m²); the laboratory and shielded room 1206 ft² (112 m²); and the office, galley, shops, and restrooms the remaining 952 ft² (88 m²). The building is located approximately 1250 ft (381 m) in a northeasterly direction from the WWVB/WWVL facility. The entire complex was designed specifically to provide a nearly dust-free environment for the six operational and two standby transmitters. However, it affords, in addition, ample laboratory space to carry out experimental measurements and tests relative to the frequency and time broadcast services and other NBS activities. Figure 4 is a photograph of the building; a drawing of the floor plan is shown in figure 5.

The transmitter room is so designed that only the front of each transmitter is accessible from an operating corridor. A view of the south operating corridor is shown in figure 6. This design not only reduces blower noise in the laboratory area, but permits more uniform and regulatory temperatures in the operating and laboratory areas and also discourages the presence of unauthorized personnel behind the transmitters.

The transmitters operate in a nearly dust-free environment. Initially, the outside air is washed, then dried by passing through evaporation filters, and finally blown and distributed through insulated ducts to each transmitter. The air-flow through the transmitters is then exhausted into a ceiling plenum chamber located around the periphery of the building above the equipment area. When the static pressure in the plenum reaches a particular level, four large fans, located on the roof, exhaust the air to the outside. Standby backup fans located in the ceiling on each side of the building are used should failure occur in the regular operating units. Figure 7 gives a photograph of the corridor behind the transmitters detailing overhead cable trays, power line disconnects, and air ducts to the transmitters.

Frequency standards, time code generators, and associated control and monitoring equipment are located in a shielded enclosure. A second shielded room is provided as part of the laboratory to carry out interference-free measurements. Both rooms are air conditioned and are temperature-controlled to $\pm 1.1^{\circ}$ C.

The standby generator room accommodates power panels and service entrance line disconnect switches and distribution circuit breaker panels. Space is provided to locate and mount two standby generators. Although a commercial power utility provides 500 kVA of three-phase Y connected power from two separate sources to the building, additional standby power is available from a 250 kW diesel

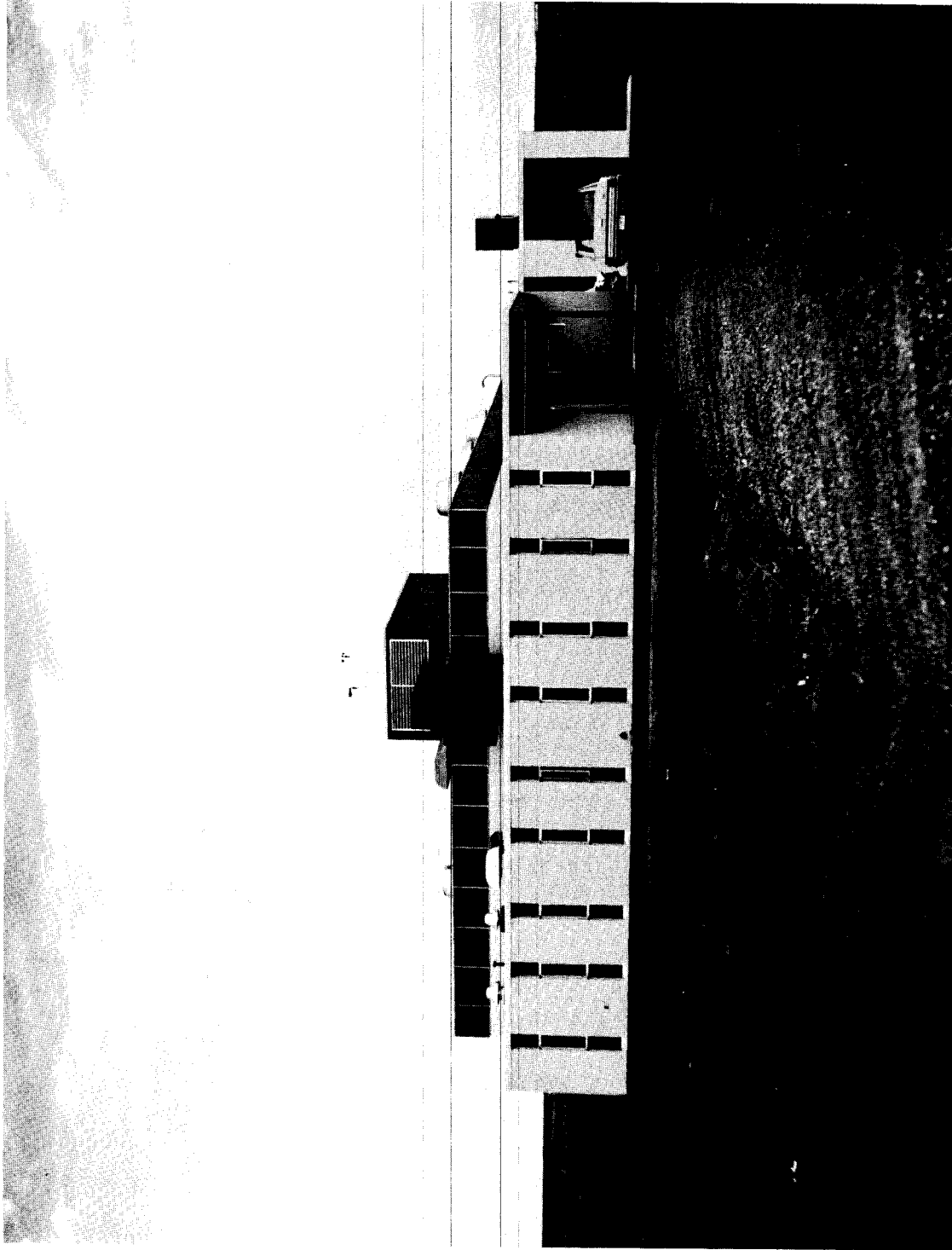

Figure 4. Photograph of the WWV transmitter building.

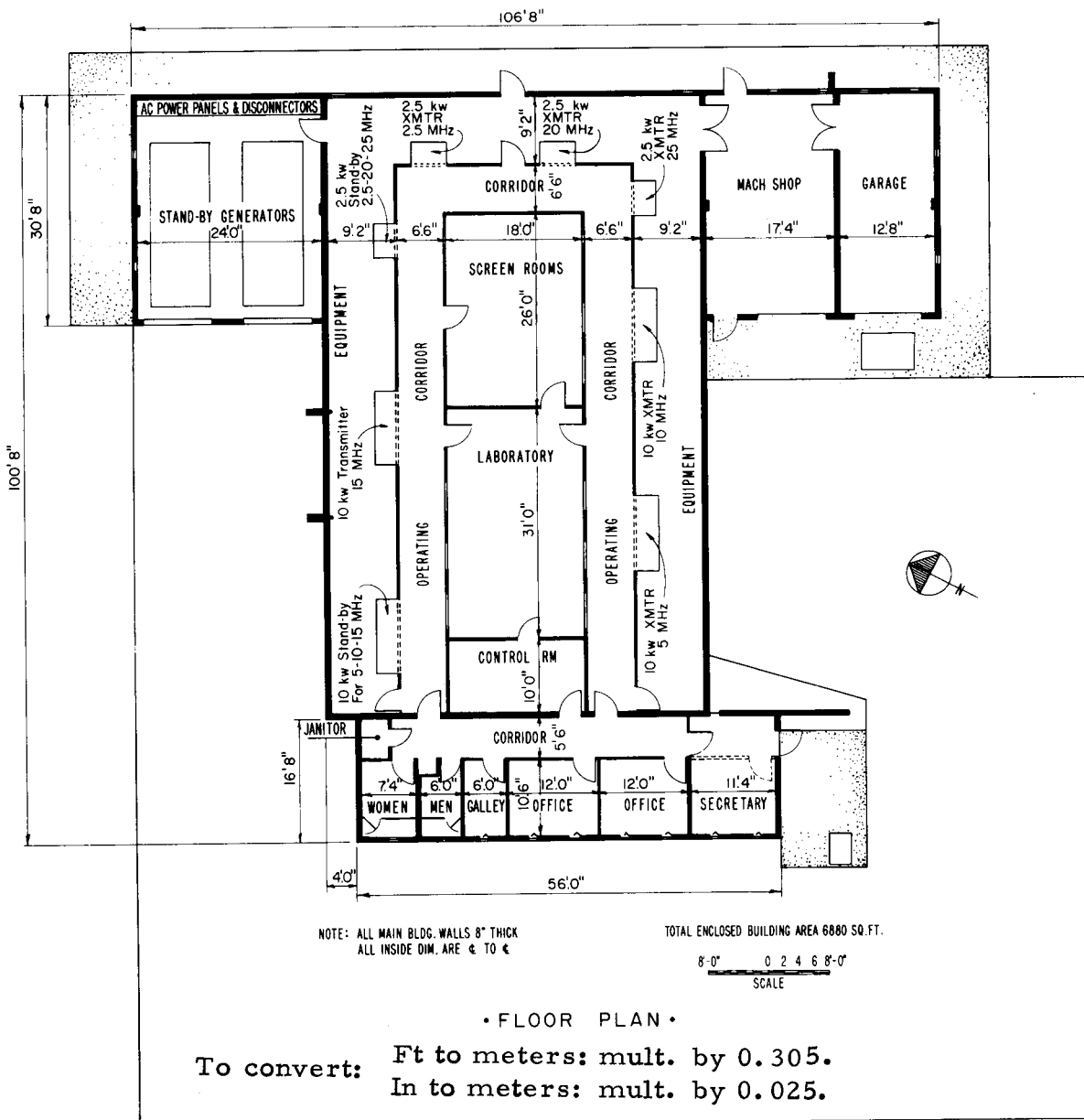

Figure 5. Floor plan of the WWV transmitter building.

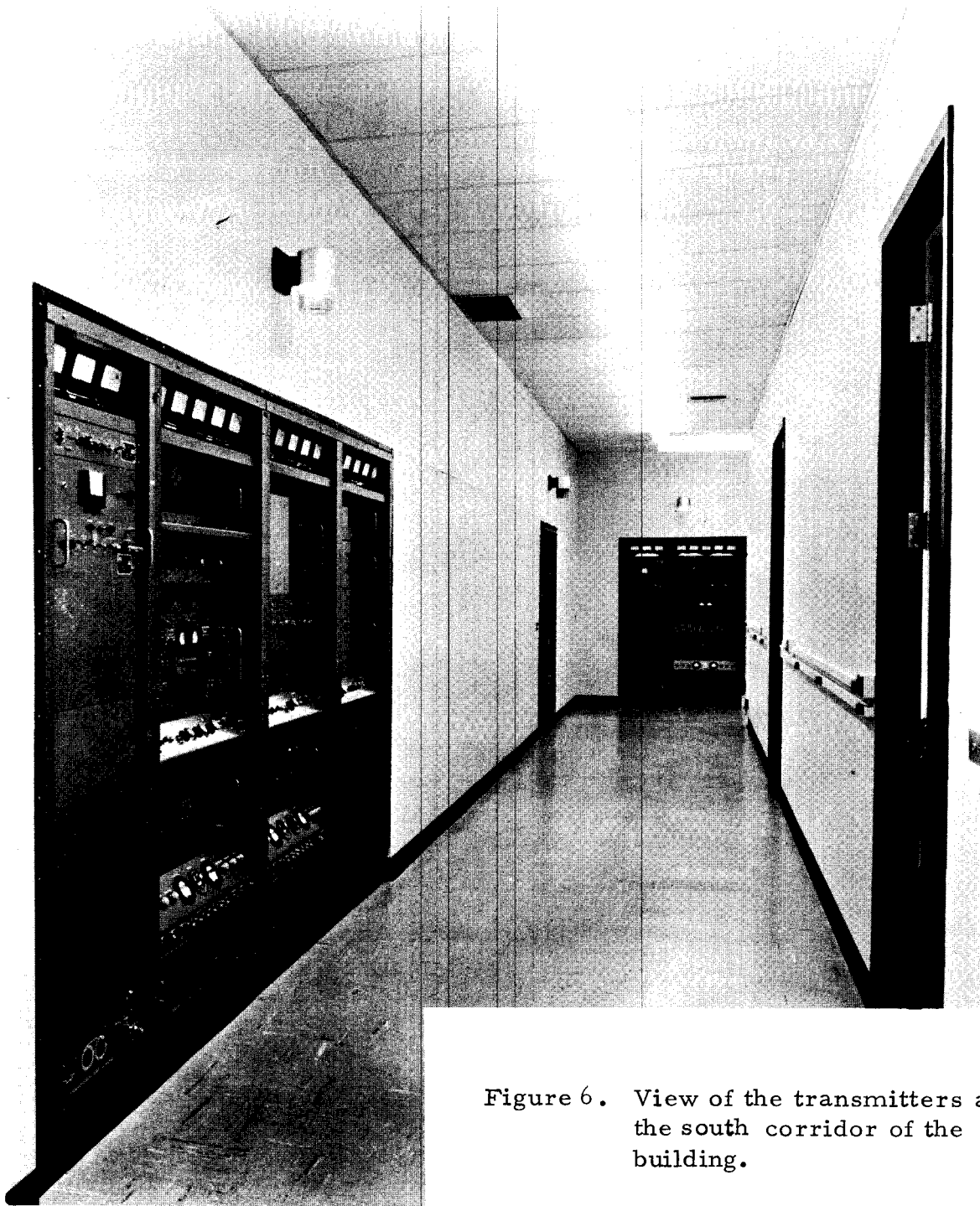

Figure 6. View of the transmitters along the south corridor of the building.



Figure 7. The south corridor of the building behind the transmitters, showing overhead cable trays, power line disconnect switch, and air ducts to the transmitters.

generator. Power, delivered to both WWVB/WWVL and WWV, is provided through electronically controlled switch gear. In the event failure occurs in the operating power source, the electronic equipment senses the failure and instantly switches to the other line. After a limited period of time it resets and switches back to the original source providing the malfunction has been corrected.

4. SYSTEM DESIGN

The WWV Fort Collins system design was based, in part, upon predicted coverage carried out by Hayden, Lucas, and Kirby [3]. The computations and analyses were made of expected geographical coverage, reliability, and noise ratio in the Western Hemisphere. These data, taking into account the seasons, solar activity, and daytime and nighttime conditions, were obtained assuming transmitter power levels of 10 kW using half-wave vertical dipole antennas and operating at frequencies of 2.5, 5, 10, 15, 20, and 25 MHz. Figure 8 gives a theoretical coverage graph of WWV for the Western Hemisphere during the summer at high solar activity using a simple antenna and a receiver with a noise figure of 10 db or less.

4.1 Antenna Design

The half-wave vertically polarized antennas employ tower sections of commercial manufacture and are designed to withstand winds up to 112 mph (180 km/h). The center-fed guyed antennas are mounted on hinged bases and fastened to concrete foundations.

The antenna is basically a modified sleeve design with the feed point located $\lambda/4$ above ground. The upper $\lambda/4$ section of the mast, appropriately insulated from the lower section, constitutes one-half of the radiating element. The lower half consists of nine sloping wires, $\lambda/4$ long, equally spaced and connected to the center mast. The wires slope downwards to the ground at an angle of 45° . The skirt, each wire appropriately insulated, not only functions as the lower $\lambda/4$ radiating section of the dipole, but also serves as mid-tower guy lines. With this arrangement, the driving point impedance is approximately 50 ohms and the current developed at the mast base-ground junction is minimized. This allows the tower to be connected directly to ground. Measurements carried out on the antennas indicated that the radial ground system did not affect antenna input impedance; the ground system was nevertheless incorporated to enhance radiation at grazing angles. Figure 9 gives the measured radiation pattern at grazing

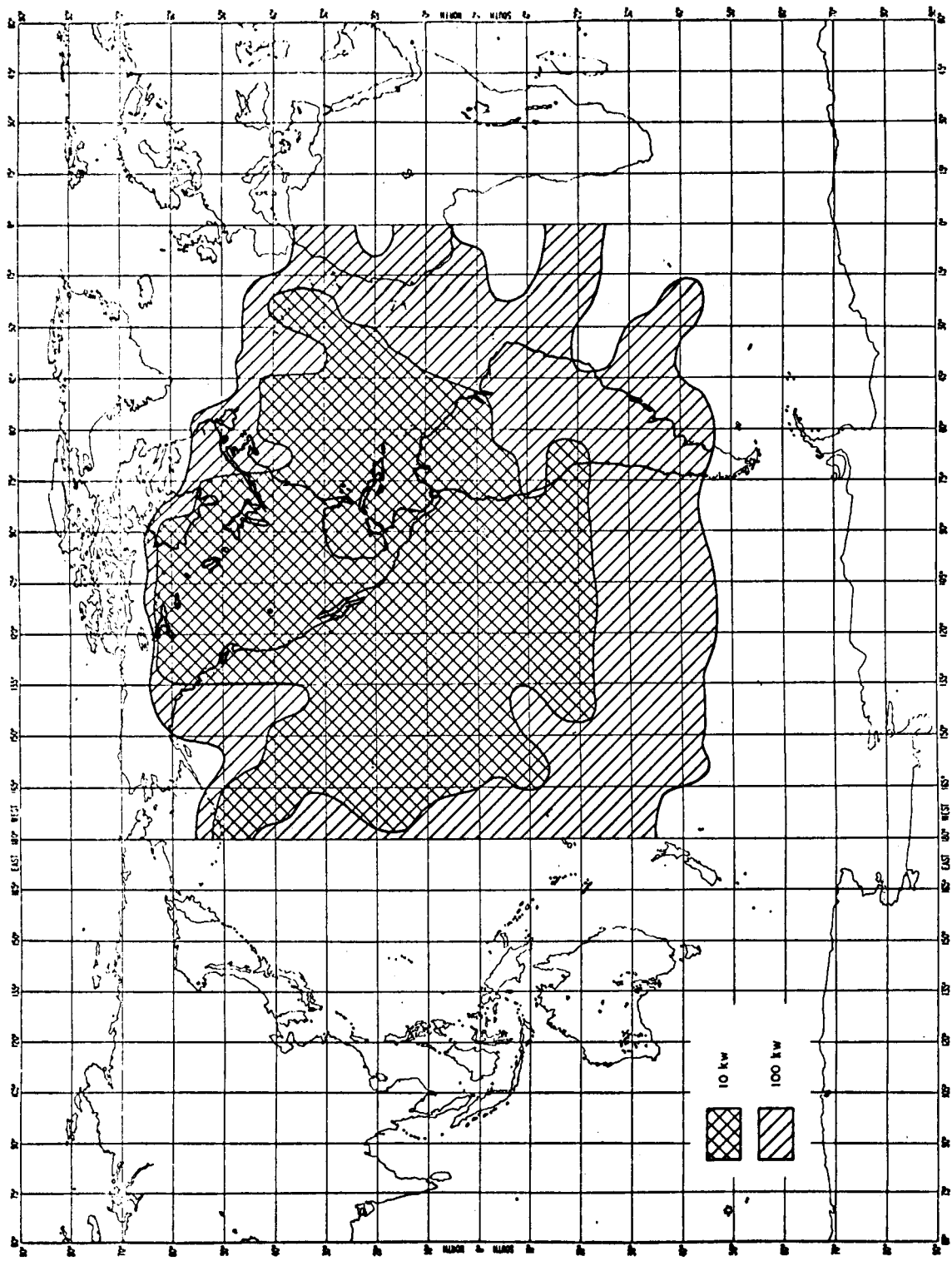
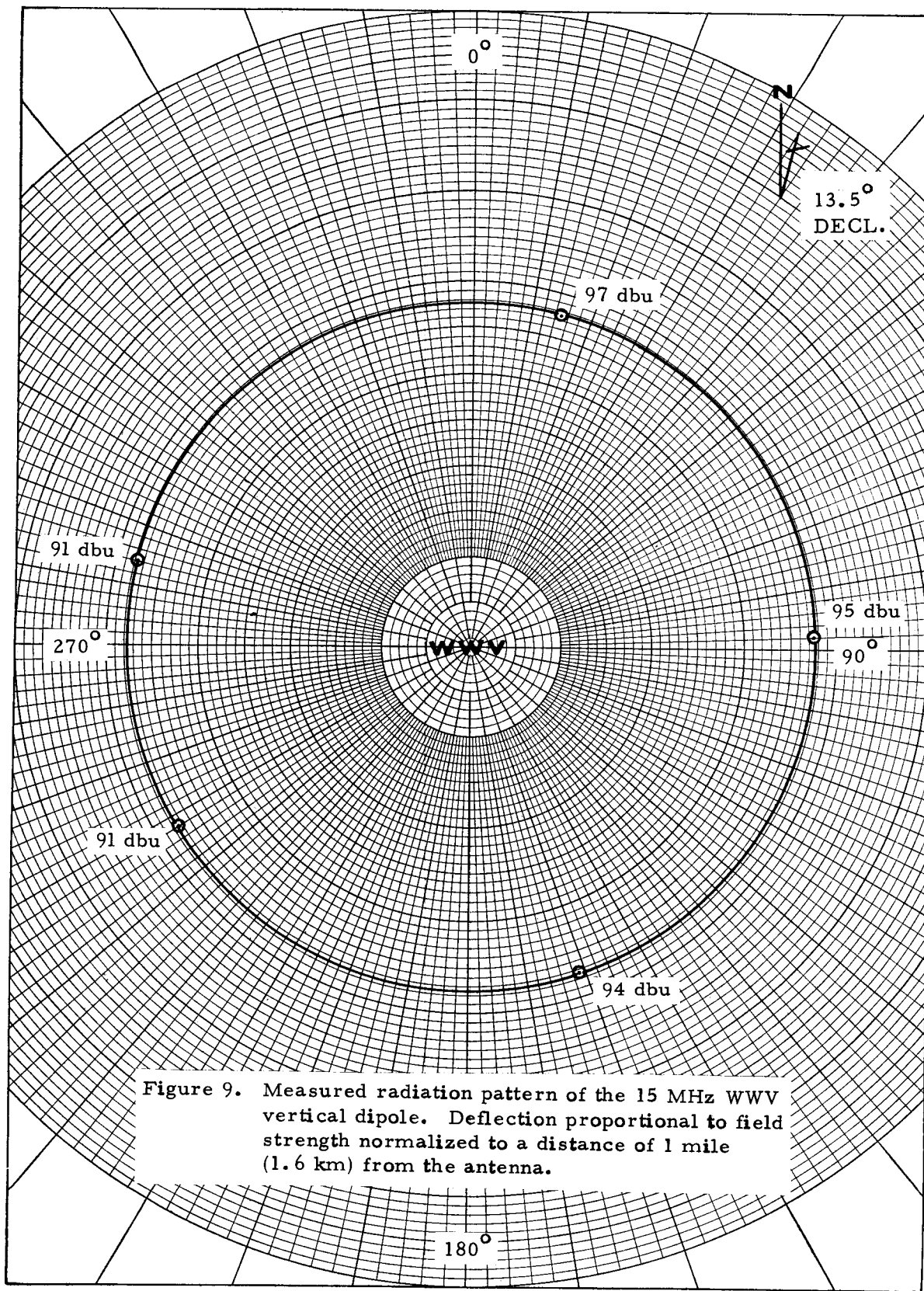

Figure 8. Graph showing theoretical coverage of WWV for the Western Hemisphere during the summer at high solar activity.



angles of the 15-MHz WWV vertical dipole in the horizontal plane. The theoretical vertical pattern of a vertical dipole fed $3/8 \lambda$ above ground is shown in figure 10 from the report by Berry, et al [4].

The antenna design is readily adaptable to a coaxial feed line and provides low-angle omnidirectional radiation. It yields a gain of approximately 1.7 db over its quarter-wave counterpart, and is easily matched through a double stub tuner. The adjustable shorting stubs, one located at the base of the tower, the other spaced $3/8 \lambda$ in the direction of the transmitter, not only match the antenna precisely to 50 ohms but also provide an effective dc ground for the system. This protects the transmitters from possible lightning damage. A drawing of the dipole antenna including design details is presented in figure 11. Figure 12 gives a photograph of the 25 MHz antenna.

Two wideband standby antennas are also fed with rigid coaxial line. These are series excited, base-fed, vertically polarized omnidirectional $\lambda/4$ monopoles. The commercially manufactured antennas are located at the center of a 36 radial wire ground screen and operate over a frequency range of 2.5 to 25 MHz. The antennas are capable of handling 50 kW average power with a nominal standing wave ratio of less than 2 to 1 when terminated in a 50-ohm load. Continuous coverage is accomplished without switching at either the antenna or transmitters. Figure 13 is a photograph of one of the antennas.

4.2 Frequency-Time Code and Control Systems

Frequency generators, multipliers, time-code generators and programming equipment are located in a 10 x 18 ft (3 x 5.5 m) shielded enclosure. A block diagram of one of three identical systems is presented in figure 14. A photograph of the equipment is shown in figure 15.

The frequency control equipment consists essentially of three complete and independent frequency generating systems. Each unit contains a cesium beam atomic frequency standard; a set of amplifiers and dividers providing 5.0, 1.0, and 0.1 MHz output frequency at the non-offset atomic frequency; a fail-safe motor-driven resolver acting as frequency offset generator; a second set of amplifiers and dividers providing 5.0, 1.0, and 0.1 MHz offset (-300 parts in 10^{10});¹ a time code generator-programmer and an rf driver unit which provides 2 W PEP (Peak Envelope Power) excitation for each of the transmitters.

¹Frequency offset to be discontinued commencing 1 January 1972.

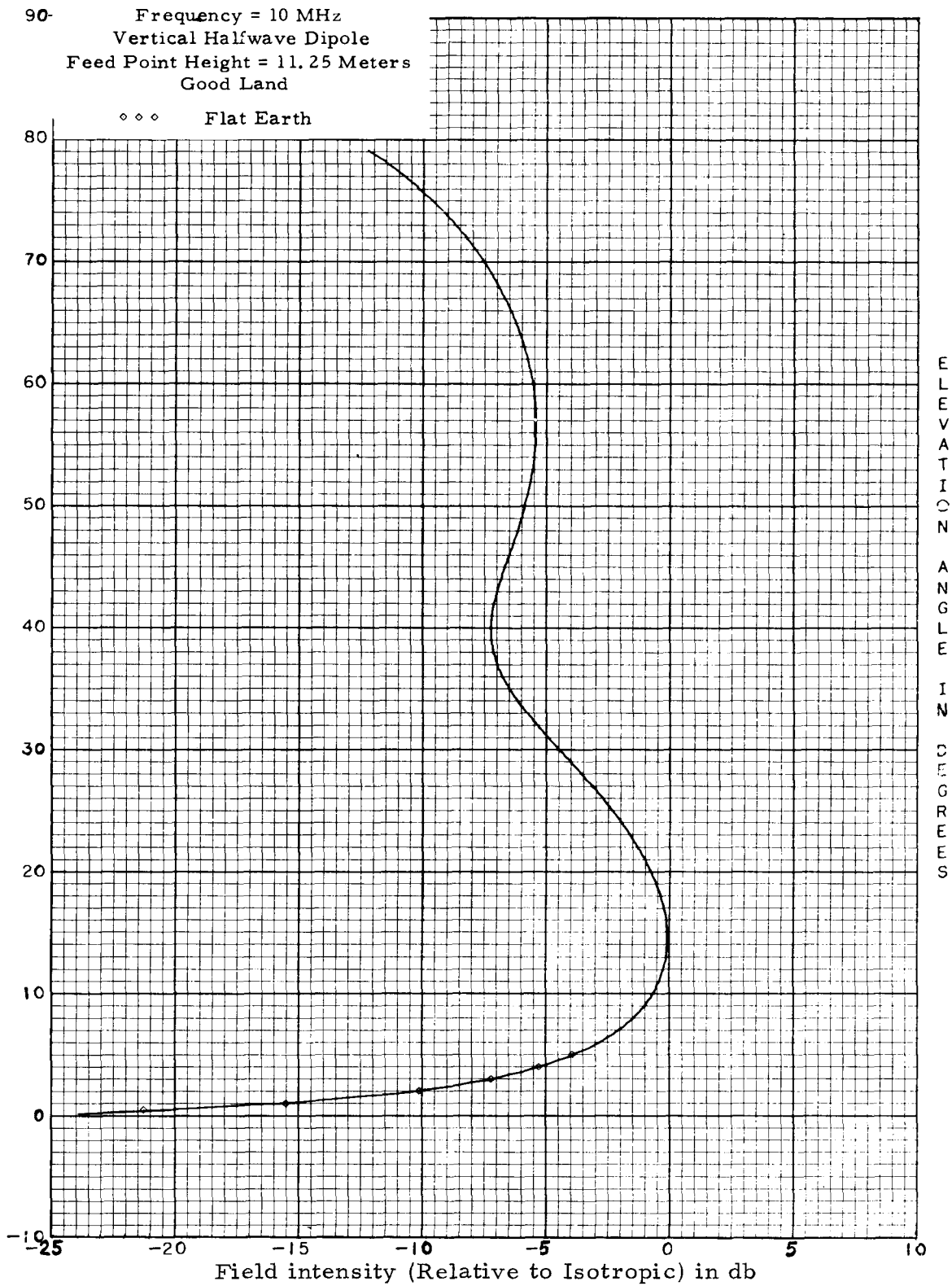

Figure 10. Vertical radiation pattern of a vertical half-wave dipole located $3/8\lambda$ above good ground. The frequency is 10 MHz.

To convert ft to meters, mult. by 0.305. To convert in to meters, mult. by 0.025.

FREQ. (MHz)	ANTENNA DIMENSIONS								
	H _A	H _T	L _A	L _{A-1}	L _M	L ₁	L ₂	R	
2.5	93'-0"	98'-6"	100'-0"	150'-0"	147'-5"	55'-4"	81'-2"	162'	
5.0	46'-0"	49'-3"	49'-0"	60'-0"	73'-8"	9'-4"	14'-7"	81'	
10.0	22'-9"	24'-7"	24'-0"	—	36'-10"	4'-1½"	6'-7¾"	40'	
15.0	15'-0"	16'-5"	15'-6"	—	24'-6"	2'-3½"	4'-2½"	27'	
20.0	11'-3"	12'-3"	12'-0"	—	18'-5"	4'-11¾"	7'-8¾"	20'	
25.0	9'-1"	9'-10"	10'-6"	—	14'-9"	3'-2½"	5'-7½"	16'	

½" diameter mylar guys support the 10-15-20-25 MHz antennas - 5/16" steel cable-insulators support the 2.5 and 5.0 MHz masts.

6 AWG soft drawn copperclad steel wire

Turnbuckles
18 inch long fiberglass insulators
45°

All tower sections constructed on 18½" equilateral triangle pattern using 1½" x ½" side rails. Cross bracing formed by continuous 7/8" solid rod fashioned into a zig-zag shape joining side rails every 15¾" and electrically welded. Hot dip galvanized finish.

Precast trans. line support posts.

Additional sets of guys and an additional set of three guy anchors are used to support the 2.5 and 5.0 MHz antennas. (See Dim. L_{A-1})

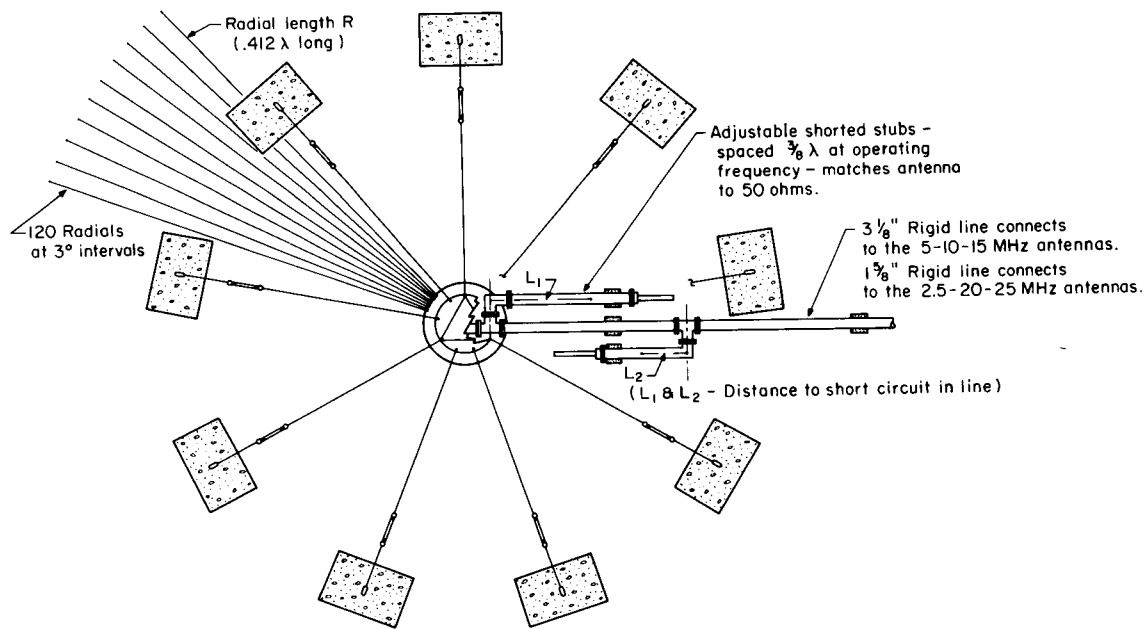

Figure 11. Design details of the WWV antennas.

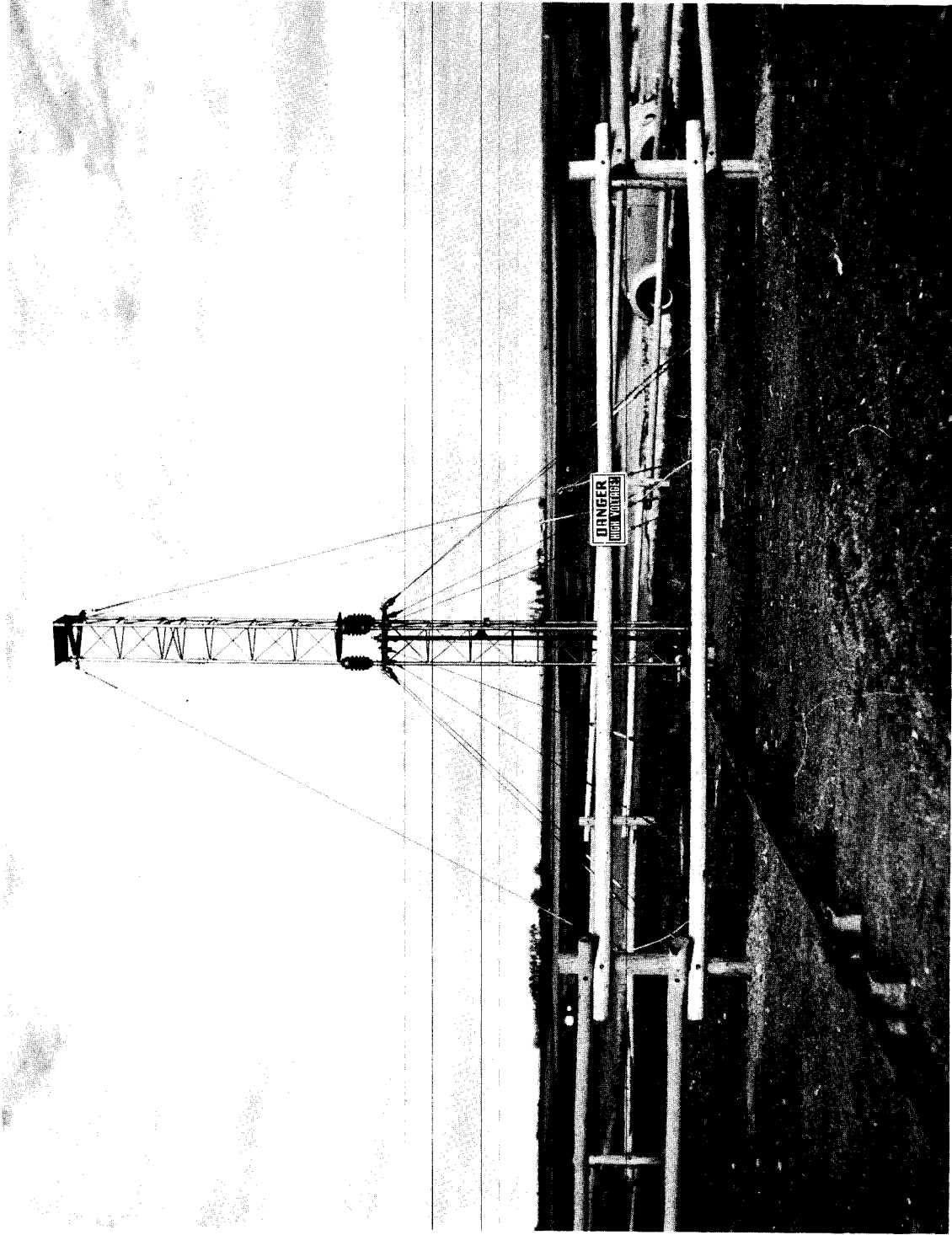

Figure 12. Photograph of the 25 MHz dipole antenna.

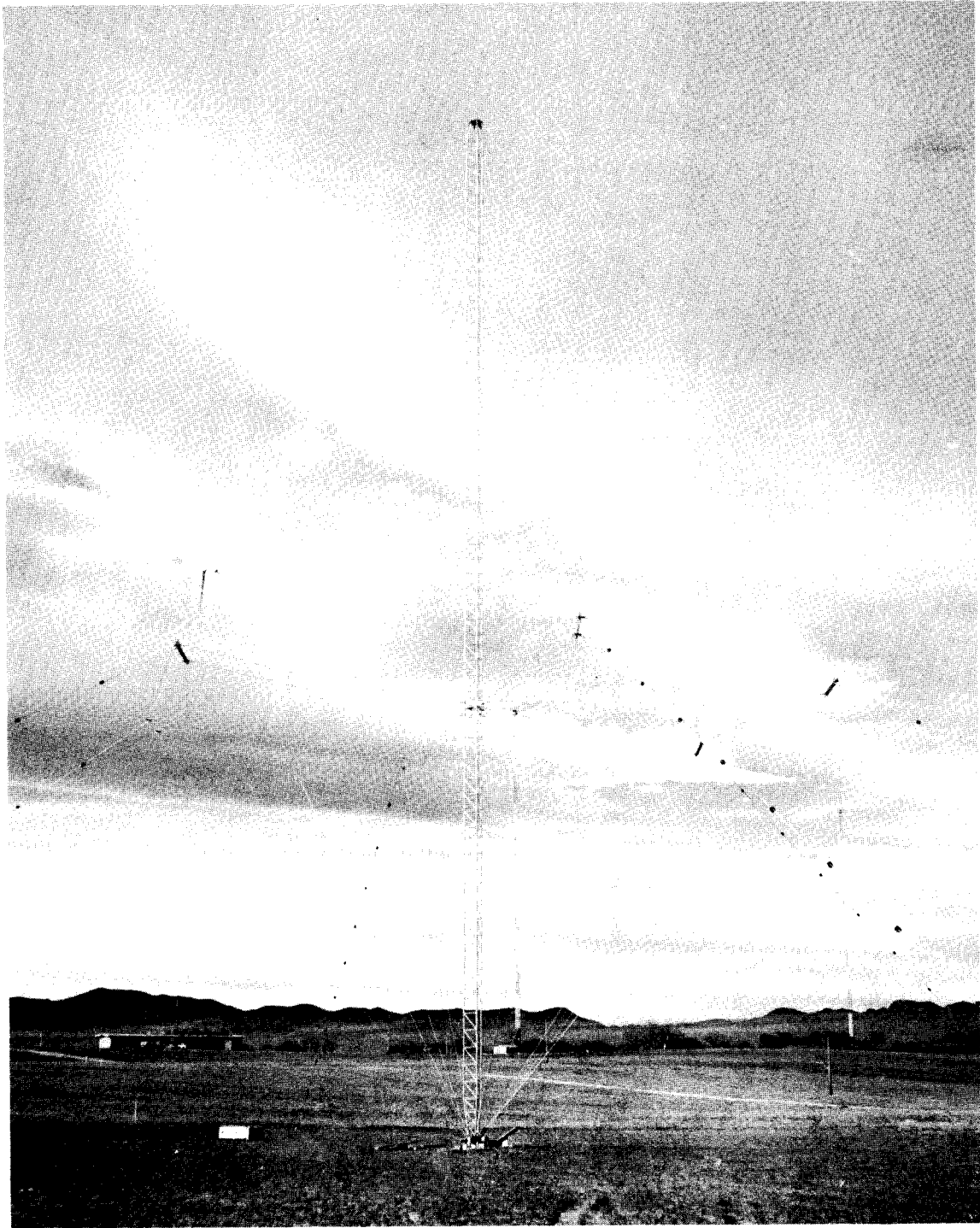

Figure 13. A view of one of the 2.5 - 25 MHz standby antennas.

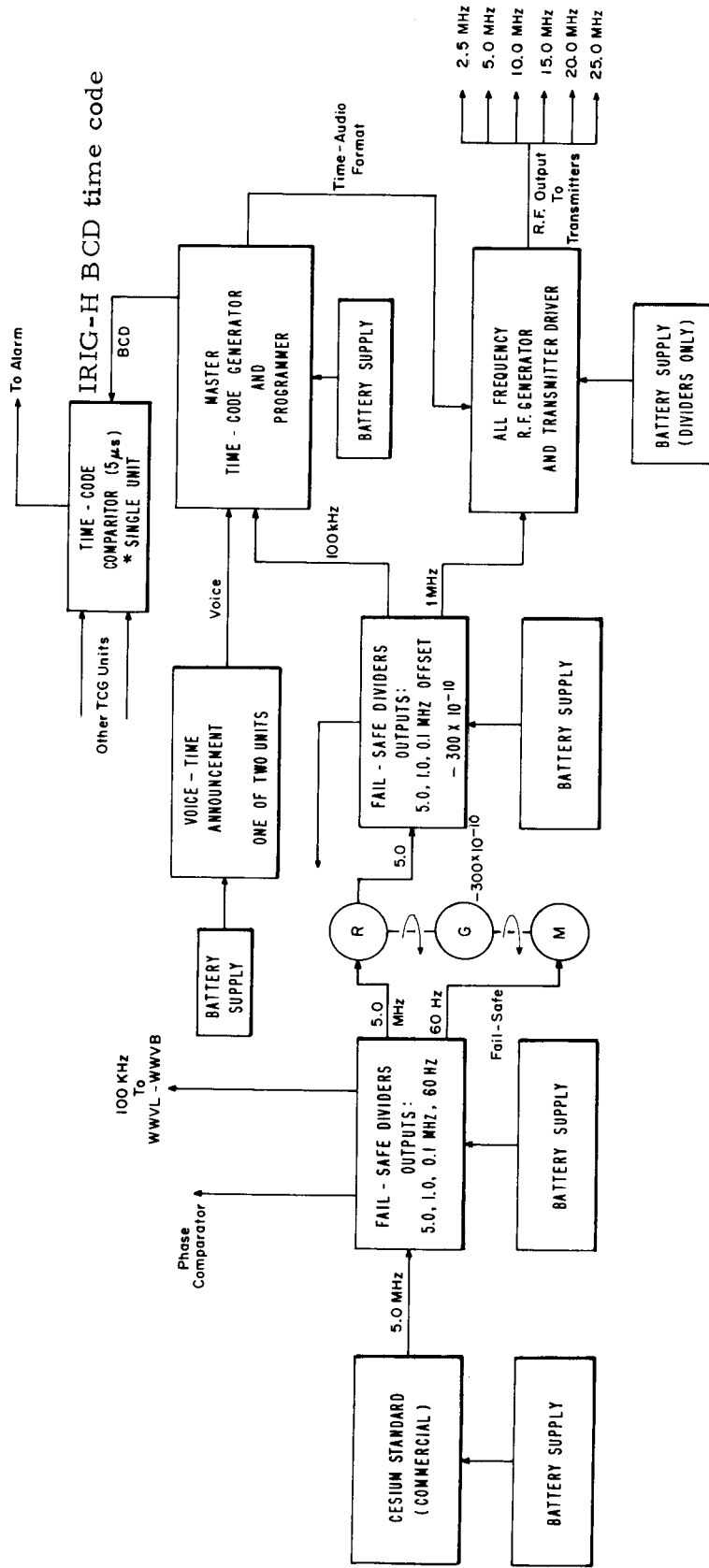

Figure 14. Block diagram of control equipment.

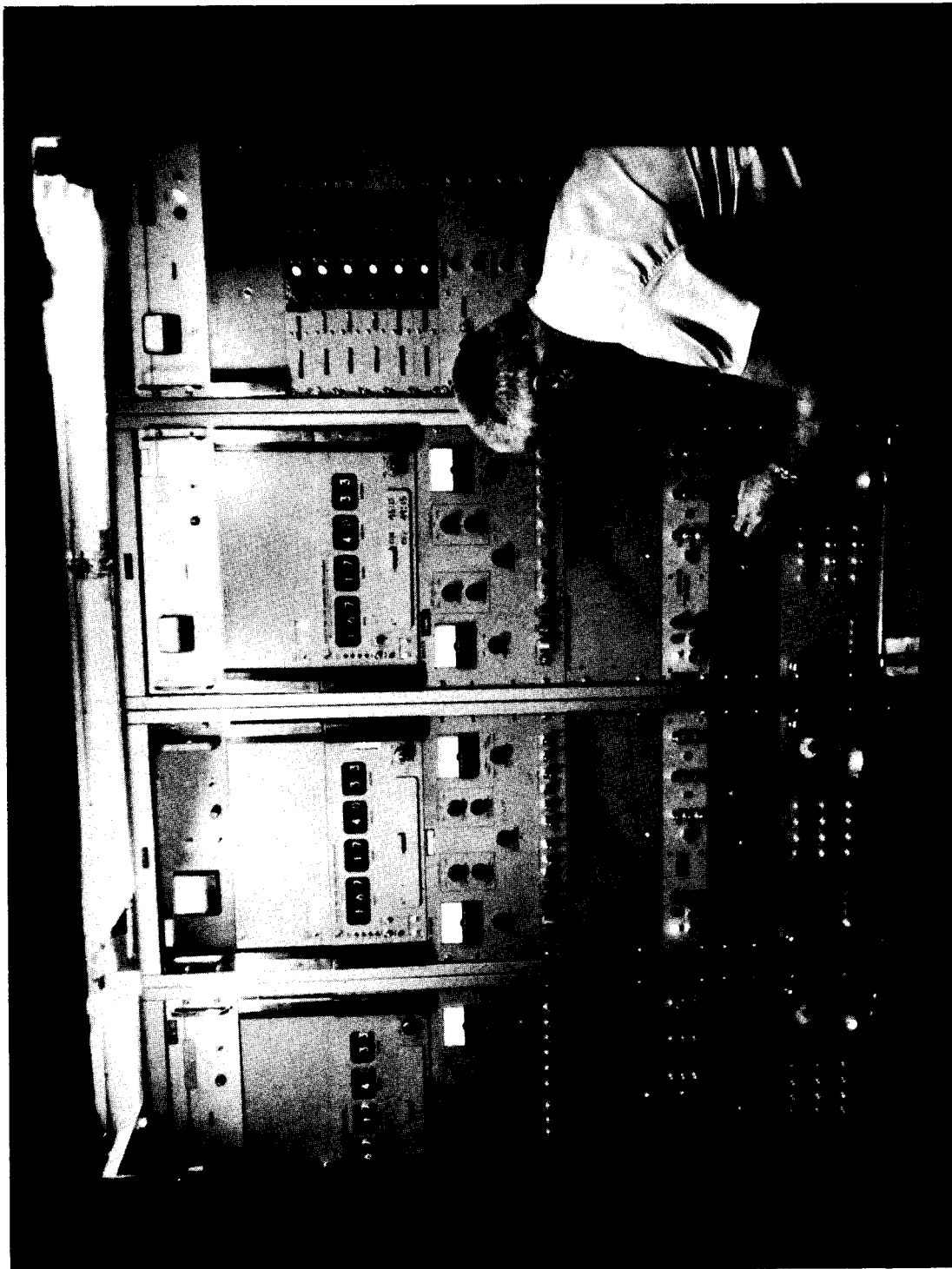

Figure 15. Photograph of control equipment.

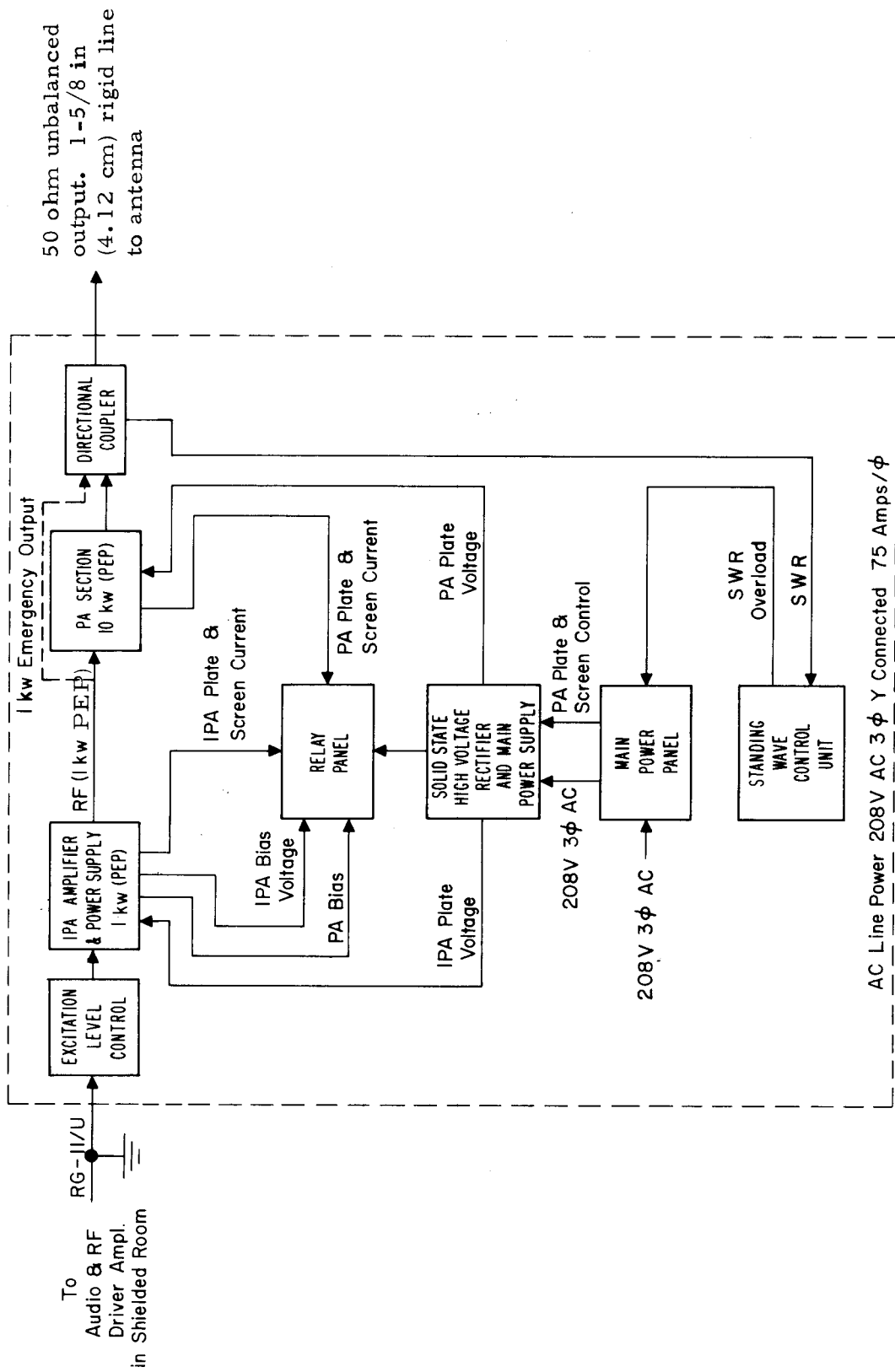

Figure 16. Block diagram of the 10 kW transmitter.

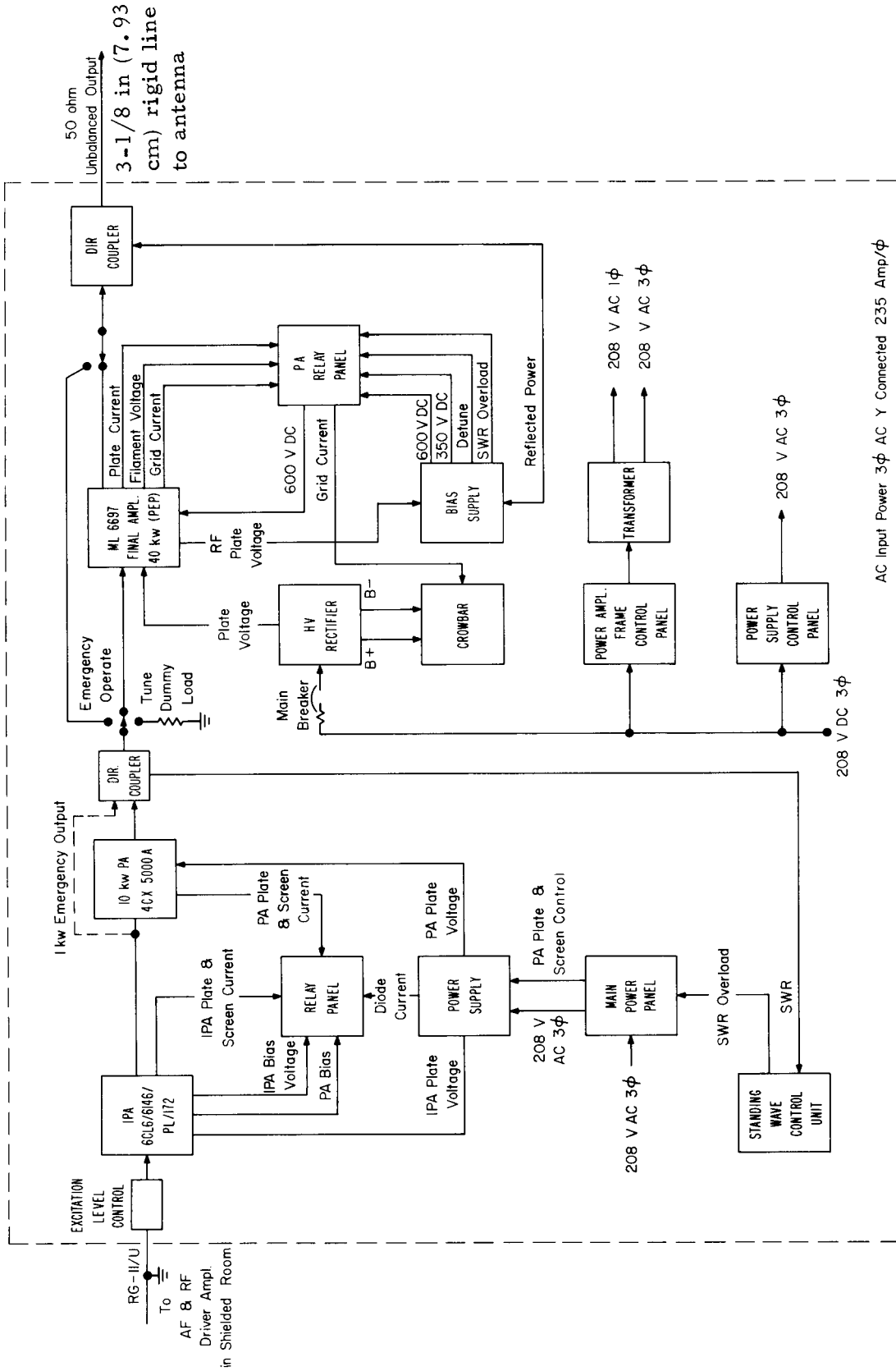

Figure 17. Block diagram of the 40 kW transmitter.

The driver is capable of either upper or lower sideband transmission with any degree of carrier insertion along with the capability of conventional double sideband amplitude modulation as currently used.

A fourth rack of equipment, used in conjunction with the three generating systems, contains the UT2 and Geoalert keyer, the coaxial switching equipment, phase-error multipliers, and phase detectors used for monitoring the output signals of the generating units.

In an adjacent area of the shielded room is a fifth rack that contains a six-channel recorder that continuously displays the phase relationships between the 1-MHz outputs of the cesium standards and the phase relationships between the 100-kHz outputs of the amplifier and divider units operating at the offset frequency. The full scale chart width on all channels is $1 \mu\text{s}$. Located in this same area are two commercial pre-recorded units used for voice announcements. Milton describes the relationship of the transmitted signals to the NBS frequency standard and the intercomparison controls in great detail [5].

4.3 Transmitters

A total of eight transmitters, six operational and two standbys, are used to broadcast frequency-time information at the station [2]. Four of the eight are rated at 40 kW PEP and are normally operated at 10 kW average power. The remaining four are rated at 10 kW PEP and operate at 2.5 kW average power. Three of the 10-kW amplifiers are connected to dipole antennas via $3-1/8''$ (7.93 cm) rigid transmission line and transmit on assigned frequencies of 5, 10 and 15 MHz. The fourth amplifier is connected to a standby antenna via similar line and operates in the 2.5 - 25 MHz frequency range. Three of the 2.5-kW amplifiers are connected to the other three operational dipoles via $1-5/8''$ (4.12 cm) rigid transmission line and transmit on frequencies of 2.5, 20 and 25 MHz. The fourth lower power amplifier is connected to a standby antenna similar to the one mentioned above. The 10- and 40-kW amplifiers are identical in design with all component parts interchangeable with one another. Figures 16 and 17 give block diagrams of the two amplifiers.

The amplifiers operate in a linear mode and connect into a 50 ohm unbalanced transmission line. The 10-kW amplifier consists of three stages of amplification, associated power supplies, and control circuits. A 6CL6, class A amplifier, couples to a 6146 linear driver that drives a class AB1 PL172 amplifier stage. This unit, capable of 1 kW rf PEP, drives a 4CX5000A tetrode. The 40-kW amplifier consists of the 10-kW

amplifier and an additional stage of amplification. The final amplifier uses an ML-6697 grounded grid triode and its associated power supplies, control, and overload circuitry.

The different transmitters, frequency and time code generator, and other functions of the two stations are monitored from two control points. One is located at WWV, the other at WWVB/WWVL. The system is designed to allow monitoring both stations from either location.

4.4 Monitoring System

Monitoring essential electronic functions at the station employs graphic recorders, visual indicators and associated audible alarms. Graphic recorders display atomic and offset atomic time on a six-channel recorder. Three channels are used to readout frequency comparisons among the three cesium beam standards. The other three channels readout the comparison among the three cesium-beam-generated offset frequencies. Similarly, functions associated with the generation of frequency, time code information, and voltages required to operate equipment located in the shielded room and those associated with the rf amplifiers are connected to visual and audible alarms. These aids are designed into console units centrally located at the two stations.

5. SUMMARY

Radio station WWV at Fort Collins, Colorado, broadcasts frequency-time information on 2.5, 5, 10, 15, 20, and 25 MHz. The station is located approximately 7 miles (11.26 km) north of Fort Collins on Highway 1 and is readily accessible by automobile from Denver and Boulder via Interstate Highway 25 or U. S. Highway 287.

Average rf power of 10 kW is transmitted on 5, 10, and 15 MHz; 2.5 kW is transmitted on 2.5, 20, and 25 MHz. Each transmitter is connected to a vertical half-wave dipole via rigid coaxial cable. Double stub tuners, located at the base of each tower, are used to adjust the antennas precisely to 50 ohms. Two additional transmitters and associated antennas are used for standby purposes.

Frequency and time are generated by cesium beam standards that are kept within ± 1 part in 10^{12} of the NBS frequency standard in Boulder, Colorado [2, 5]. Associated time code generators, offset generator, audichrons, Geoalert keyers, frequency multipliers, recording and

monitoring equipment function integrally to provide a worldwide frequency-time broadcast service with transmitted accuracies up to 5 parts in 10^{12} .

6. ACKNOWLEDGMENTS

Appreciation is extended to R. S. Gray for his valuable assistance in fabrication of antenna transmission lines, antennas, and measurements of antenna parameters in the early stages of building construction; to J. B. Milton and E. Rogers for the design and development of frequency control and other electronic equipment; and to G. Hicks for her untiring and diligent secretarial services.

7. REFERENCES

- [1] NBS, Standard frequency and time signals WWV and WWVH, Proc. IRE (Corresp.), 44, No. 10, 1470-1473 (Oct. 1956).
- [2] Viezbicke, P. (Editor), NBS frequency and time broadcast services--radio stations WWV, WWVH, WWVB, WWVL, Nat. Bur. Stand. (U. S.), Spec. Publ. 236, 1971 edition, 13 pages (July 1971).
- [3] Haydon, G. W., Lucas, D. L., and Kirby, R. C., Predicted coverage of WWV Fort Collins for 10 and 100 kilowatts (Unpublished report).
- [4] Berry, L. A., and Chrisman, M. E., Linear high frequency antennas over a finitely conducting spherical earth, ESSA Tech. Report IER 8-ITSA 8, 117 pages (Sept. 1966).
- [5] Milton, J. B., Standard time and frequency: its generation, control, and dissemination from the National Bureau of Standards Time and Frequency Division, Nat. Bur. Stand. (U. S.), Tech. Note 379, 27 pages (Aug. 1969).

NBS TECHNICAL PUBLICATIONS

PERIODICALS

JOURNAL OF RESEARCH reports National Bureau of Standards research and development in physics, mathematics, chemistry, and engineering. Comprehensive scientific papers give complete details of the work, including laboratory data, experimental procedures, and theoretical and mathematical analyses. Illustrated with photographs, drawings, and charts.

Published in three sections, available separately:

• Physics and Chemistry

Papers of interest primarily to scientists working in these fields. This section covers a broad range of physical and chemical research, with major emphasis on standards of physical measurement, fundamental constants, and properties of matter. Issued six times a year. Annual subscription: Domestic, \$9.50; \$2.25 additional for foreign mailing.

• Mathematical Sciences

Studies and compilations designed mainly for the mathematician and theoretical physicist. Topics in mathematical statistics, theory of experiment design, numerical analysis, theoretical physics and chemistry, logical design and programming of computers and computer systems. Short numerical tables. Issued quarterly. Annual subscription: Domestic, \$5.00; \$1.25 additional for foreign mailing.

• Engineering and Instrumentation

Reporting results of interest chiefly to the engineer and the applied scientist. This section includes many of the new developments in instrumentation resulting from the Bureau's work in physical measurement, data processing, and development of test methods. It will also cover some of the work in acoustics, applied mechanics, building research, and cryogenic engineering. Issued quarterly. Annual subscription: Domestic, \$5.00; \$1.25 additional for foreign mailing.

TECHNICAL NEWS BULLETIN

The best single source of information concerning the Bureau's research, developmental, cooperative, and publication activities, this monthly publication is designed for the industry-oriented individual whose daily work involves intimate contact with science and technology—for *engineers, chemists, physicists, research managers, product-development managers, and company executives*. Annual subscription: Domestic, \$3.00; \$1.00 additional for foreign mailing.

Order NBS publications from:

Superintendent of Documents
Government Printing Office
Washington, D.C. 20402

NONPERIODICALS

Applied Mathematics Series. Mathematical tables, manuals, and studies.

Building Science Series. Research results, test methods, and performance criteria of building materials, components, systems, and structures.

Handbooks. Recommended codes of engineering and industrial practice (including safety codes) developed in cooperation with interested industries, professional organizations, and regulatory bodies.

Special Publications. Proceedings of NBS conferences, bibliographies, annual reports, wall charts, pamphlets, etc.

Monographs. Major contributions to the technical literature on various subjects related to the Bureau's scientific and technical activities.

National Standard Reference Data Series. NSRDS provides quantitative data on the physical and chemical properties of materials, compiled from the world's literature and critically evaluated.

Product Standards. Provide requirements for sizes, types, quality, and methods for testing various industrial products. These standards are developed cooperatively with interested Government and industry groups and provide the basis for common understanding of product characteristics for both buyers and sellers. Their use is voluntary.

Technical Notes. This series consists of communications and reports (covering both other agency and NBS-sponsored work) of limited or transitory interest.

Federal Information Processing Standards Publications. This series is the official publication within the Federal Government for information on standards adopted and promulgated under the Public Law 89-306, and Bureau of the Budget Circular A-86 entitled, Standardization of Data Elements and Codes in Data Systems.

Consumer Information Series. Practical information, based on NBS research and experience, covering areas of interest to the consumer. Easily understandable language and illustrations provide useful background knowledge for shopping in today's technological marketplace.

NBS Special Publication 305, Supplement 1, Publications of the NBS, 1968-1969. When ordering, include Catalog No. C13.10:305. Price \$4.50; \$1.25 additional for foreign mailing.