

Nationwide Precise Time and Frequency Distribution Utilizing an Active Code Within Network Television Broadcasts

DAVID A. HOWE

Abstract—Because of the increasing interest in time and frequency dissemination via television signals, the National Bureau of Standards (NBS) has sponsored an experiment using an active time and frequency code transmitted on a U.S. television network encompassing nationwide coverage. Some history of the project is given. The format of the television code and the equipment necessary to generate and decode the transmitted information are discussed. Statistical results of system stability from New York City, New York, to Boulder, Colorado, and to Los Angeles, California, are presented, and comparisons are made with earlier observations using the passive line-10 television time synchronization technique and the 3.58-MHz color-burst frequency reference used for colorcasts. Analysis of the frequency-transfer capability is presented, and the ability of a phase-locked oscillator to lock to the code's frequency reference is discussed. With the decoder's oscillator in a locked condition, plots of phase with respect to time, time domain stability using the Allan variance, and spectral noise reveal that the system permits calibration of a remote standard to one part in 10^{11} within one-half hour. Long-term stability (several days) is typically a few parts in 10^{12} . Using an active time code, short-term stability is governed to a noticeable degree by the television industry's standard video format. Finally, a schematic diagram, with discussion, outlines how time-of-day information can be extracted from the television code used in this experiment.

I. INTRODUCTION

WITH MORE and more atomic frequency standards and precision crystal oscillators being developed, it is becoming important that an effective and inexpensive method of frequency and time calibration be available for remote locations. Throughout the continental United States the television networks provide an extensive high-quality signal distribution system that feeds major cities and has sufficient bandwidth to enable dissemination of precise time and frequency information.

Experiments completed previously between the National Bureau of Standards and Newark Air Force Station, Ohio, using the ABC, CBS, and NBC¹ television networks, indicate that the distribution system is very stable with respect to both short- and long-term measures [1]. The method of measurement utilized line 10 (tenth line of the odd field of video) in the 525-line system as a time transfer. This has come to be called the passive line-10 synchronization method and is widely used in areas where a common television network or station may be monitored at two receiver sites simultaneously. With this method it is necessary that the two sites be time synchronized previous to taking measurements to within 33 ms, the ambiguity of the technique. (The period of the recurrent line 10 is approximately 33 ms.) The time of arrival of line 10 at each site must then be coordinated either through joint communication or by relating measurements to published data from the National Bureau of Standards (NBS) or US Naval Observatory (USNO). At some TV stations cesium beams are used to control the line-10 rate, and time-of-coincidence (TOC's) are predicted in advance [2]. Both initial calibration and reduction of data for the passive line-10 system represent time-consuming labors to many people; the chief advantage of the system lies in its low cost. In Europe where the technique was first explored, the use of television signals for time comparisons (passive method) is regularly used as a method of clock synchronization [3]. The atomic clocks in Fort Collins, Colo., used as references for the radio transmissions of WWV, WWVB, and WWVL, are compared to the clocks maintained at the NBS Boulder laboratory through the use of coordinated line-10 identification of a regional television station.

Manuscript received April 20, 1972. This paper was presented at the 26th Annual Frequency Control Symposium.

The author is with the Frequency Time Dissemination Research Section, National Bureau of Standards, Boulder, Colo. 80302.

¹The results of this report are not to be used for advertising or promotional purposes, or to indicate endorsement or disapproval of the product(s) and/or services of any commercial institution by the National Bureau of Standards.

Along with every color broadcast, the major TV networks transmit a short burst 3.57 . . . MHz signal at the start of each horizontal line to be used as a phase reference for demodulation of the color information. Each network derives its color-burst signal from a rubidium-controlled oscillator/synthesizer whose output is usually stable to within one part in 10^{12} per day [4], [5]. By being phase locked to this burst reference frequency, a color TV set's 3.57 . . . MHz oscillator possesses good stability characteristics. For comparison, data of color subcarrier phase-locked oscillator stability are included.

The NBS has for several years been experimenting with a scheme of transmitting time-of-day and frequency information via television. If a standard frequency reference is available at a television network studio, a method of duplicating this standard frequency at a remote location is possible via some unused portion of the television format. The standard television format in the U.S. calls for 525 horizontal lines, comprised of two interlacing fields that generate one frame of video. Picture information is contained on 485 horizontal lines (nominal), while the remaining forty lines are used for vertical sync and delay at black level to allow time for receiver vertical retrace. With two fields there exist twenty lines per field that are not seen by the viewer if his television set is properly synchronized. It is during the 20-line period, normally referred to as the vertical interval, that coded time and frequency signals may be transmitted. Initial experiments were conducted using line 16 as the carrier (lines 17-20 are reserved for special functions of interest to the TV industry) [6], [7]. After surveying the effects on home television receivers of coded information in the vertical interval, we thought it would be most advantageous to use line 1.

The active line-1 TV time system developed by Davis of NBS offers distinct advantages over many existing dissemination methods utilized within the continental U.S. Of principal interest is the short measurement period required for a time or frequency calibration. The system typically permits calibration of a remote standard to one part in 10^{11} within one-half hour. Of course, for determining long-term stability of a remote oscillator, longer measurement times are required. If one evaluates the effectiveness of a time and frequency distribution system, keeping in mind accuracy, precision, ease of acquisition, cost, flexibility, reliability, etc., then the use of a network television time code is attractive. From television decoding equipment, the user could obtain the following signals [8]:

- 1) time of day as binary-coded decimal (BCD) logic that can interface directly with a digital clock,
- 2) 1-MHz standard frequency that exhibits good stability for use by broadcasters, industry, laboratories, or anyone wishing to obtain a frequency reference that is phase coherent with an NBS standard,
- 3) time tick, 1 pps, which is an on-time pulse once each second to be used in conjunction with a time interval counter and remotely originated time tick.

In order to implement the system on a nationwide scale, atomic frequency standards (primary and standby), along with

time code generating equipment, would be needed at the network originating studio. The complete package of encoding equipment could be installed at other originating studios for the same or another network in order to acquire greater coverage. The television affiliate would transmit the code when telecasts originate from the network. This would require no additional equipment, except in cases where processing amplifiers regenerate the vertical interval. In these instances a code-bypassing device could be used in conjunction with the processing amplifier (line-1 bypass unit). The affiliate with a separate time code generator could choose to regenerate the time code so that it is on the air at all times.

The cost is low for decoding equipment capable of an accuracy within 33 ms with a time-of-day demodulator, line count, and control costing about \$20 for parts. (An inexpensive decoder is discussed at the end of this manuscript.) If better precision is needed, then this requirement may also be satisfied, but at higher costs; i.e., with the present state-of-the-art, a time and frequency decoder capable of precision to a few nanoseconds yields a price tag of about \$1000.

With the aid of the American Broadcasting Company's television network, the NBS sponsored an experiment of the active line-1 system. Authorization for the time and frequency code was granted beginning October 23, 1971 for experimental tests, and this paper outlines the results of those tests.

II. SOME ASPECTS OF TIME AND FREQUENCY DISTRIBUTION BY MEANS OF NETWORK TELEVISION

From the point of view of time and frequency dissemination, it is desirable to reproduce the time and frequency at any given location as precisely as possible referred to an adopted standard. There are two fundamental types of information that are transmitted via the active television system: 1) time interval that can be related to frequency, frequency being the inverse period of an oscillation, and 2) the date, or clock reading, that often has been called epoch. (We prefer the use of the word date because epoch has alternate meanings that could lead to confusion.)

In principle, if one had perfect clocks, one could synchronize them once and they would remain synchronized forever. There are two basic reasons in practice why the synchronization does not persist. First, systematic (nonrandom) effects such as frequency drift, frequency offset, and environmental effects on equipment often cause time dispersion. These must be analyzed and each problem solved at a particular location. Secondly, there are different kinds of random noise, or what one might call nondeterministic kinds of processes, that affect these time and frequency systems. These latter processes can typically be classified statistically [5].

III. THE ACTIVE TELEVISION CODE

Standard television broadcasts in the U. S. utilize a 525-line format to generate one video frame. The television screen is scanned from top to bottom twice to produce one frame by use of two interlaced fields (odd then even) of $262\frac{1}{2}$ lines each. Referring to Fig. 1, we see that the vertical interval contains no picture information. Unique sync pulses, which comprise

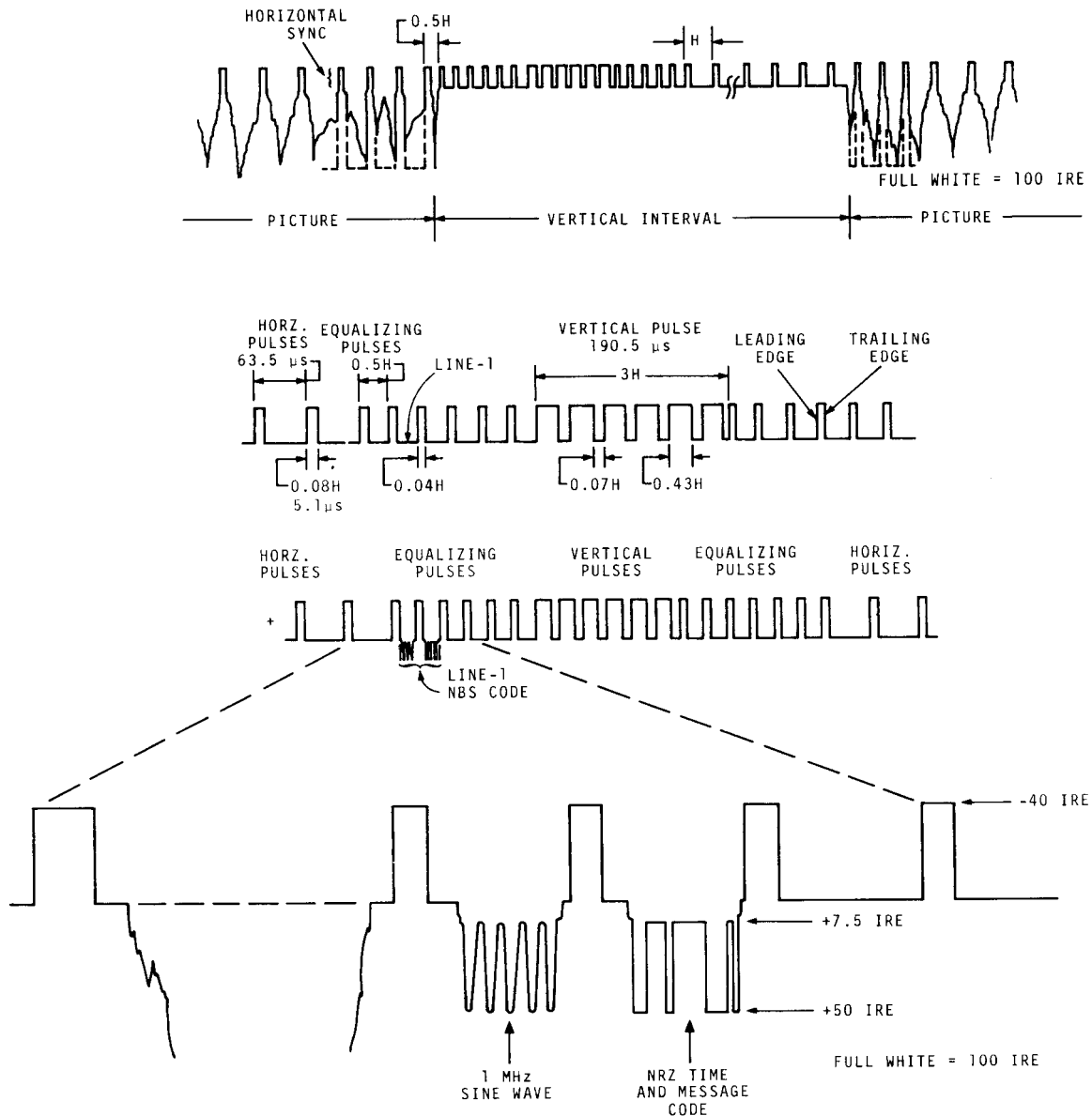

Fig. 1. Waveforms of U.S. television format, vertical interval, and NBS experimental line-1 code (H = horizontal line period of $1/15\ 750$ s or $63.5\ \mu\text{s}$).

the vertical pulse, are used to identify the beginning of a field. The vertical pulse is repeated at a rate of approximately 60 Hz (one for each field). Note that the added time and frequency signal on line 1 of the vertical interval has a level reaching approximately 50 percent of maximum white level. Therefore, the signal is visible on the screen as a series of small dots if one rolls the picture to observe the vertical interval. The first half of line 1 contains a 1-MHz sine wave that is derived from a reference cesium atomic standard; the second half of line 1 is modulated by time-of-day and communications messages using a nonreturn-to-zero (NRZ), BCD, and ASCII alphanumeric code. The 1-MHz signal may be used as the reference for a phase-locked oscillator (PLL) at a receiver site. The available sampling time is necessarily short ($\sim 12\ \mu\text{s}$) and the sampling rate is equivalent to television picture field rate (~ 60 Hz).

IV. EXPERIMENTAL PROCEDURE

By the use of an extensive U. S. television network, the experiment accomplished an important goal by simulating as closely as possible the proposed layout necessary to obtain time and frequency distribution on a permanent basis. From Fig. 2 we see that the ABC television network is joined directly to many major cities. The map indicates locations of primary affiliates. In many parts of the U. S., secondary affiliates re-broadcast the signal originating from a primary television station. These secondary affiliates are scattered primarily in the Rocky Mountain and central states. ABC has about 600 affiliates in all.

A cesium atomic standard with adjoining clock was used as a time code reference at ABC, New York, and calibrated on time just prior to leaving the Boulder lab (October 15, 1971). At

the receiver site at the Boulder lab, a vector voltmeter was used to indicate relative changes of phase between the decoder's locked 1-MHz PLL and a local cesium reference. The regional affiliate for ABC is KBTB, channel 9, Denver, Colo. Because Boulder is shadowed by mountainous terrain relative to KBTB-9's transmitting antenna, it is difficult to obtain a strong signal; however, with a highly directional yagi, a clear picture reasonably free of ghosts was receivable. The antenna was a 15-element yagi feeding low-loss RG-8U coaxial cable approximately 150 ft above ground. Equipment interconnection is shown in Fig. 3(b).

The ambiguity of the phase measurements of the 1-MHz line-1 signal referred to a locally generated 1 MHz is $1 \mu\text{s}$. To resolve beyond $1 \mu\text{s}$, the decoder contained a time interval counter referred to 1 pps derived from the local cesium clock. The counter had a resolution of 1 ns, which made it a good crosscheck to the measurements observed on the phase record. The time interval counter was updated by the line-1 time code and stopped by the locally generated 1 pps; the number was valid when the decoder received a true parity check of the encoded microseconds data.

Phase versus running-time measurements were started each day at 1630 GMT (the time at which KBTB-9 starts broadcasting network feeds), and they continued until 2130 GMT for the five-day work week. Except for one half-hour period of local news, KBTB-9 rebroadcasts ABC's feed throughout the allotted time span. Of course, station breaks and some commercials originated locally. The programs were soap operas and quiz shows primarily that were, for the purposes of time distribution, excellent. They generally originate from one location (video tape playback studio) and network line switches were minimal, i.e., there were few paths rerouted to join or leave affiliates for specific programs.

Because there is a large time-of-day difference from the East to the West Coast of the U.S., most of the western area receives ABC programming delayed by tape. Fortunately, from the point of view of time distribution, tape delaying is not accomplished by individual affiliates (except perhaps in a few scattered instances); rather, the West Coast affiliates acquire programming from a central point in Los Angeles, Calif. In order to accommodate the West Coast affiliates, a complete package of line-1 coding equipment with cesium standard was installed at KABC, Los Angeles (November 10, 1971). With this second installation, the experiment was extended to include essentially all affiliates of ABC. Soon after, a television receiver-decoder (high resolution) was set up in Santa Clara, Calif., for equipment evaluation at a standards laboratory there and to establish a base for further data acquisition. Phase comparisons versus time were made between the frequency standard installed at KABC and the one used at the Santa Clara site.

A point at which beneficial measurements were made was Los Angeles, Calif. Phase records of the line-1 1-MHz signal originating from New York as received in Los Angeles would uncover information about the longest network path. By examining the worst case condition of a system, one is able to define more accurately the limitations of its precision. A vector voltmeter used as a phase comparator and a strip chart

recorder were installed at KABC and wired as at the NBS Boulder site (November 18, 1971). At KABC, the demodulator, that is, the portion of the decoder that converts the TV time code to serial BCD, worked well for signals originating from WABC, New York City, and after a slight adjustment of the demodulator, decodes were obtainable very nearly 100 percent of the time.

In all, the experiment involved three high-resolution receiver sites that were able to record data. A number of decoders with message processors were distributed to some points primarily for advertising the system as well as allowing evaluation by interested people.

V. DATA

Fig. 3(a) shows a typical day-long record of relative phase of the decoder's 1-MHz PLL versus a cesium frequency reference at the Boulder receiver site. Typically, the first network telecast was received at 1630 GMT. At the outset, chart full scale was equivalent to $1\text{-}\mu\text{s}$ phase shift. From about 1640 to 1655 GMT, we observed essentially a straight-line phase record. (Perfect straight lines appearing at the center of the chart represent a code absent condition commonly due to local programs, commercials, and station identifications.) Shortly before 1700 GMT the local affiliate initiated a studio switch that appeared as a 400-ns path step. From 1700 to 1715 GMT our television receiver experienced interference from a nearby earth-to-satellite VHF transmission. The 1-MHz PLL still locked to the signal from New York but with greater uncertainty. Prior to 1730 GMT, the systems at the receiver site were checked, and the chart was calibrated and expanded to a full scale of 333 ns. From 1730 GMT until the end of the time-signal transmission, the equipment remained untouched. Once each minute, the 1-MHz signal was turned off briefly to identify the beginning of the minute, and this portion of the format created a slight perturbation of the decoder's locked oscillator. Occasionally, a half-hour program required a path switch. One notes such a case from 2000 to 2030 GMT of Fig. 3(a). This type of switch occurred infrequently (about once each week); usually it was small as in this example.

The one-minute chart record (Fig. 3(a)) shows the phase noise to be more or less random. Maximum short-term excursions of the 1-MHz PLL were about 5 ns with good reception of the local affiliate. Since the lab at Boulder is in a fringe area with respect to television reception from Denver, weather anomalies and aircraft caused variations in signal intensity and multipath. This most likely accounts for the apparent drift of the intensity of phase noise; i.e., the changing width during the day-long record. We have observed that short-term instabilities in the network path from New York City to Boulder are small enough that with a television signal of $500 \mu\text{V}$ or more (typical for clear picture), a phase record for a 15-minute interval permits calibration for a remotely located oscillator to one part in 10^{11} using the line-1 active system. In the example of Fig. 3(a), one sees a frequency offset of approximately 3×10^{-12} .

Fig. 4(a) is a plot of relative cesium drift (networks versus an NBS Cs clock) for the path from New York to Boulder during the period December 1, 1971-January 27, 1972; path changes

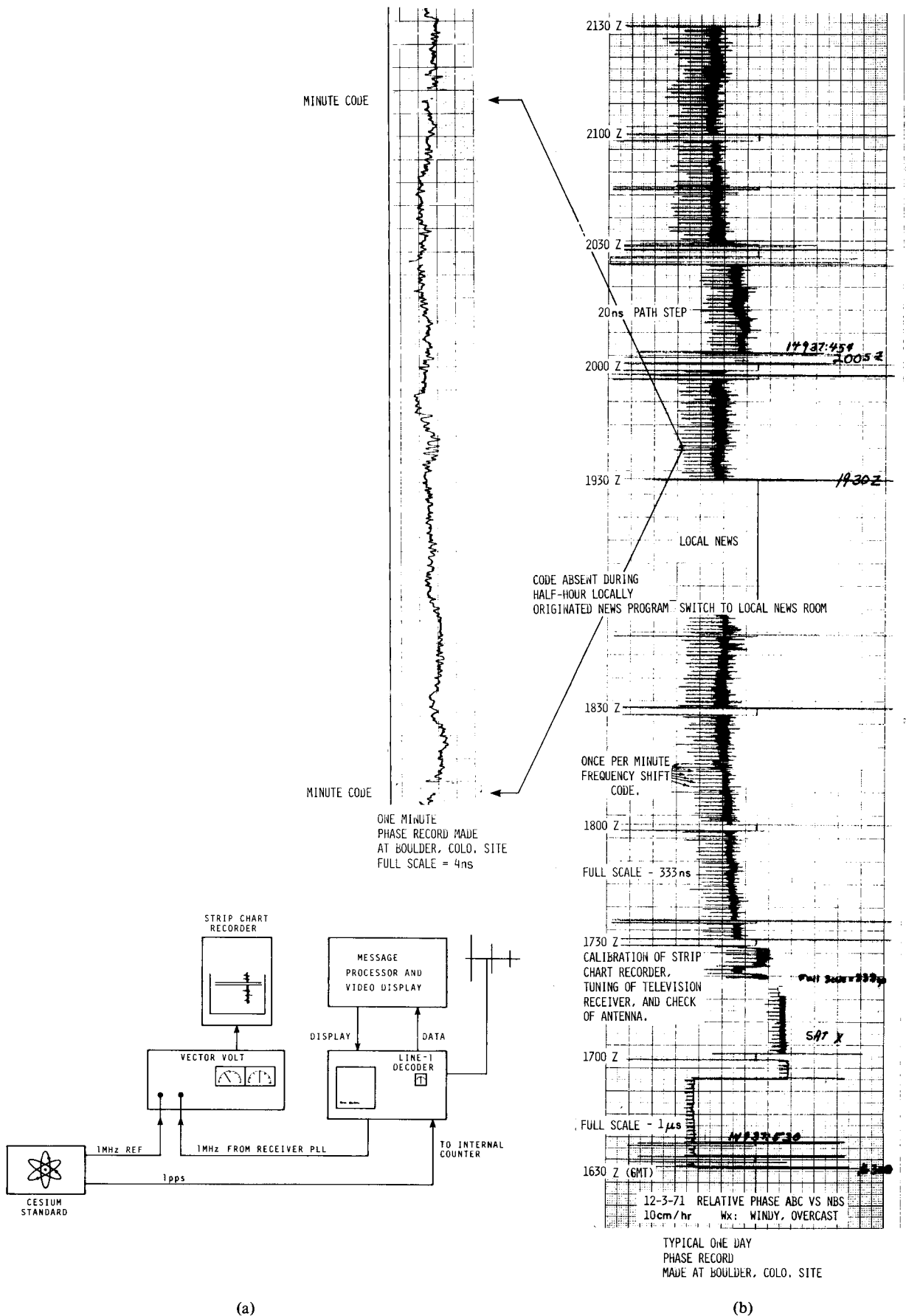
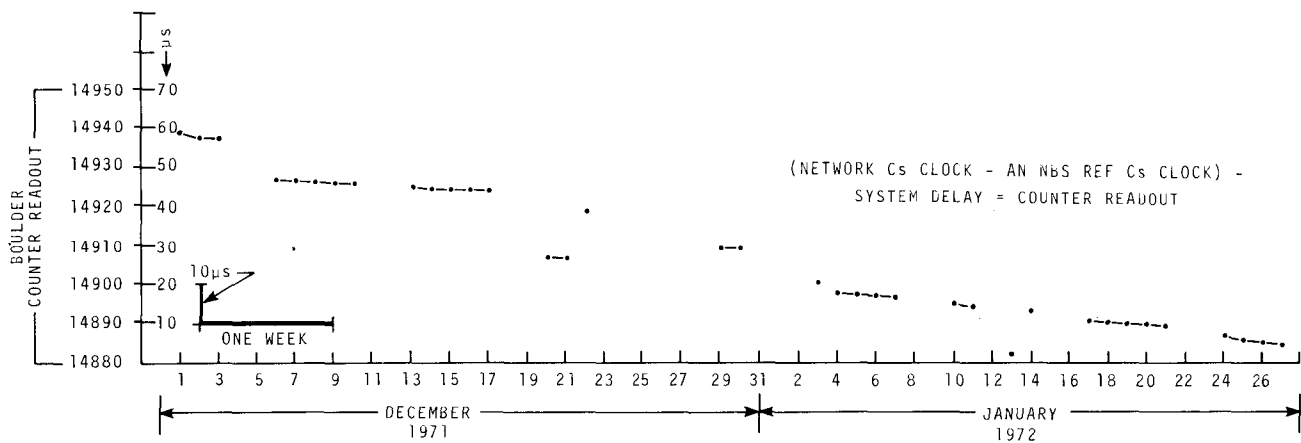
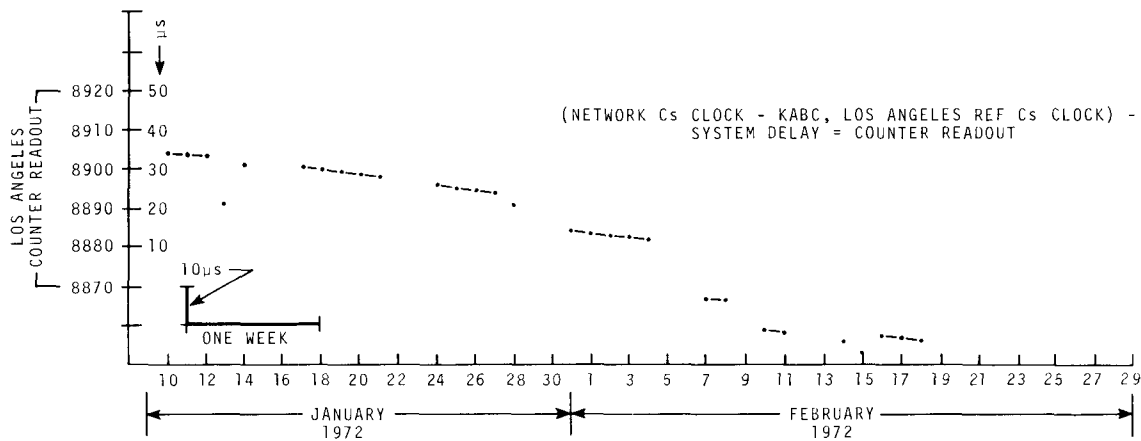

Fig. 3. (a) Typical phase versus time measurements for one minute (full scale = 4 ns) and for one day (full scale = 333 ns). (b) Equipment layout for phase versus time measurement.



(a)



(b)

Fig. 4. Plots of day-to-day clock differences between the network Cs standard (New York, N.Y.) and (a) Cs standard at NBS, Boulder, Colo., with offset $\sim 13 \mu\text{s}/\text{month}$, and (b) Cs standard at KABC, Los Angeles, Calif., with offset $\sim 15 \mu\text{s}/\text{month}$.

are evident as jumps in the microseconds decode, which appear as inconsistencies with respect to day-to-day trends. For the path from New York City to Los Angeles, Fig. 4(b) indicates long-term stability (network Cs versus KABC, Los Angeles, Cs clock) for the period January 10, 1972-February 18, 1972.

Although path switches from New York seemed to occur often during the weekend (no data were taken during weekends, but time-of-arrival of the code on Monday mornings was frequently different from that observed the previous Friday), the network path was generally undisturbed for the duration of one work week. The cause for weekend path changes was probably due to the large number of special television programs usually broadcast at this time. One might assume that when regular programming was resumed, the path delay would return to its previous value. This was not always the case; however, the week-to-week data indicated that the network attempted to achieve very nearly the regular routing after the programming of special features.

The active line-1 TV system transmits date information to the nearest microsecond. The active system's time synchronization should display the equivalent precision of the television line identification technique. Based on results using the passive line-10 system, time synchronization throughout most of the continental U.S. is possible to within $10 \mu\text{s}$ [1]. The results

put forth in Figs. 4(a) and 4(b), showing long-term stability using the active system, maintain this precision.

VI. FURTHER MEASUREMENTS OF THE STABILITY OF THE 1-MHZ PLL

The raw data outlined above are useful to many individuals interested in precise frequency and time. Throughout the discussion it may be assumed that the decoder's phase-locked oscillator is locked to the transmitted 1-MHz signal referred to the cesium frequency standard at the New York television studio. But using a vertical interval signal, how well does the decoder's oscillator lock to the reference; i.e., how closely does the stability of a remote locked oscillator resemble that of the reference cesium? The discipline of a phase-locked oscillator is dependent upon a variety of parameters such as signal-to-noise ratio of the incoming reference, signal purity, sample rate, and dead-band time.

In order to disclose more about the performance of the system, a number of tests were conducted to evaluate the local oscillator at the Boulder site in its locked condition. The following measurements were made (only the frequency and phase fluctuations were measured): 1) time domain, σ_f using the Allan variance [9], $0.001 \text{ s} \leq \tau \leq 10^3 \text{ s}$ and 2) frequency domain, spectral density plot $S_{\sigma\phi}$.

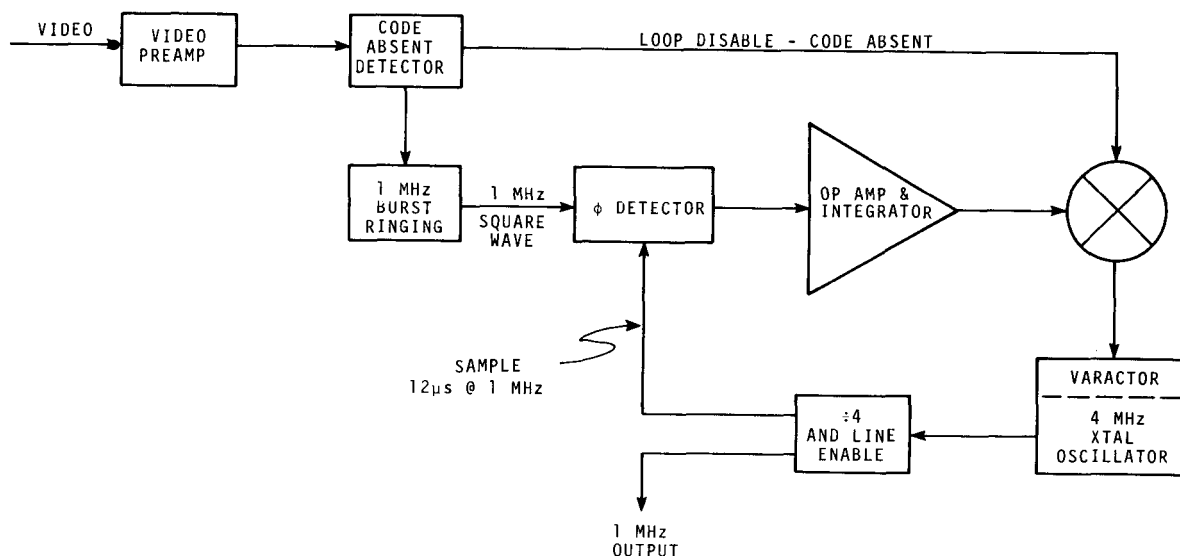

Fig. 5. Block diagram of phase-locked oscillator that uses TV line 1, 1-MHz sine wave as reference.

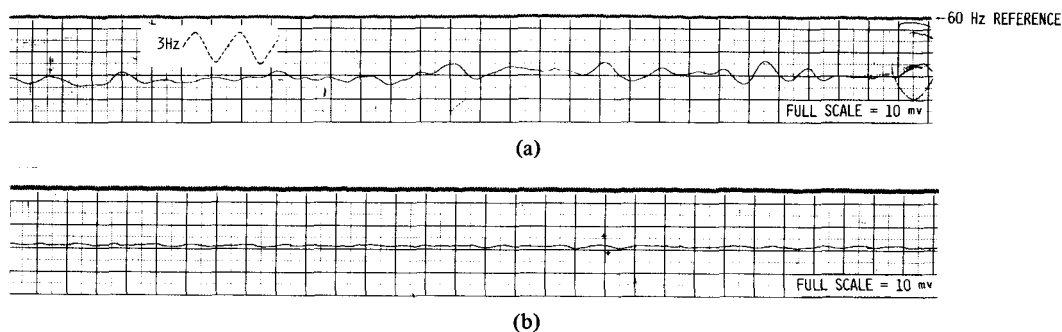

Fig. 6. 1-MHz oscillator loop error voltage when (a) locked to signal from New York as received in Boulder (note dominant 3-Hz noise) and (b) locked to local time code generator. Measurements taken at NBS Boulder receiver site.

The 1-MHz line-1 signal is used as the reference for a phase-locked oscillator, or PLL, at a receiver site. When the signal is present, a voltage-controlled crystal oscillator (VCXO) is utilized as a slave; it represents a very simple and inexpensive means of making available at a receiver location a good 1-MHz signal derived from the TV code. Fig. 5 shows a block diagram of the phase-locked oscillator. All components used, including the crystal for the oscillator, had relatively loose tolerances; yet, all eleven of the decoder PLL's built for the experiment worked flawlessly. The sample time is $12 \mu\text{s}$ with a sample rate of 60 Hz (nominal); thus, a deterioration of spectral purity is possible at 60 Hz since once every 60th of a second, a new loop error voltage is acquired. However, if one is willing to sacrifice acquisition of lock time and gain lower short-term noise by affixing a long time constant to the PLL, then instabilities due to loop noise may be forced to emerge at a much lower frequency. Our receiver PLL usually required several seconds to acquire a locked condition. Loop noise was dominant at 3 Hz when locked to the signal from New York. This is indicated in the loop error voltage plot of Fig. 6(a). The loop time constant was approximately 1 s. For comparison, the same PLL was fed by a nearby encoder and cesium reference. Fig. 6(b) shows that loop noise was considerably less (1/10 intensity) but still revealed a dominant 3 Hz.

It is standard practice to accumulate data at a constant repetition rate with a period of sampling T . Each data point is an average over a time τ called the sample time. The total number of data points taken in a continual set of data is M . Further, for every measurement system there exists a high-frequency cutoff usually called the measurement system bandwidth f_B such that noise at frequencies greater than f_B will be attenuated and nonrelevant. The standard deviation as a statistical measure of such a data set is commonly given by

$$\sigma_{\text{standard deviation}} = \left\{ \frac{1}{M-1} \left[\sum_{i=1}^M (z_i - \bar{z})^2 \right] \right\}^{1/2} \quad (1)$$

where z_i denotes the i th data point and \bar{z} denotes the average of all M of the z_i . For most measurements of the precision of time and frequency distribution, it has been shown that $\sigma_{\text{standard deviation}}$ depends upon M , T , τ , and f_B and they are always noted if one uses Allan variance notation [9]-[11]:

$$\sigma^2 = \langle \sigma^2(N, T, \tau, f_B) \rangle, \quad (2)$$

where the angle brackets denote the expectation value. If $N = M$, then (2) is exactly the expectation value of the squared standard deviation. A very useful time domain measure of frequency stability that has been recommended by the IEEE

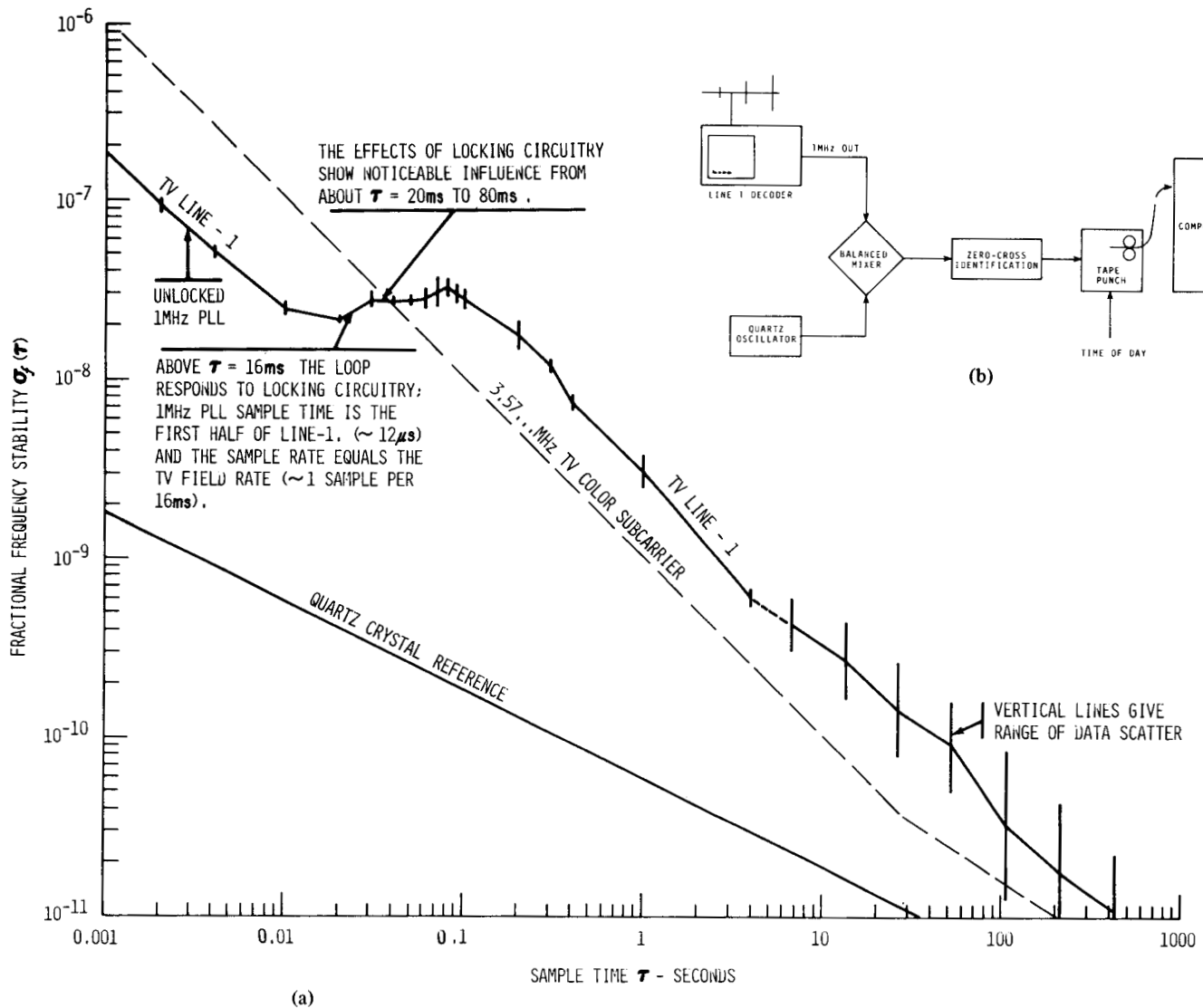

Fig. 7. (a) $\sigma_{f_{req}}$ versus τ of active TV line 1, 1-MHz PLL. ($1 \text{ ms} < \tau < 15 \text{ min}$). The same measure of 3.57954... MHz PLL derived from network color subcarrier is shown for comparison (dashed line). (b) Schematic for measuring time domain stability for $6 \text{ s} < \tau < 400 \text{ s}$.

Subcommittee on Frequency Stability [10] is defined as follows

$$\sigma(\tau) \equiv \langle \sigma^2 (N = 2, T = \tau, \tau, f_B) \rangle^{1/2}. \quad (3)$$

In this analysis of data, the procedure defined by (3) will be followed.

Measurements of short-term stability were accomplished by means of a counter with a stable crystal oscillator reference. σ_f was computed for $N = 2, \tau = 1 \text{ ms} \rightarrow 10 \text{ s}$. The number of sets averaged varied from $10^4 \rightarrow 2$. Fig. 7(a) is the plot of short-term stability in the time domain with the 1-MHz phase-locked oscillator at Boulder locked to WABC, New York; it also indicates scatter of σ_f . For periods less than approximately 10 ms, one expects to observe stabilities dictated by the quality of the oscillator used in the decoder. There was very little difference between measurements acquired for a locked versus an unlocked VCXO in the region $\tau = 1 \text{ ms} \rightarrow 10 \text{ ms}$. Above 16 ms the loop affects the stability of the VCXO since the error voltages are governing or steering the

VCXO to maintain phase coherence with the signal from New York. Recall that the 1-MHz PLL sample time is the first half of line 1 ($\sim 12 \mu\text{s}$) and the sample rate is the television field rate (\sim once per 16 ms). Fig. 7(a) reveals that the effects of the locking circuitry show noticeable influence starting at about 20 ms; phase-correcting actions of the PLL cause an increase in instability until about 80 ms. After some experimenting it appeared that a loop time constant of approximately 1 s yielded the best compromise between acquisition-of-lock time and good short-term stability. The hump in the plot of σ versus τ at $\tau \approx$ television field rate can be suppressed if one chooses a long acquisition-of-lock time, but it is not entirely avoidable.

In the case of a 3.57... MHz color subcarrier PLL, the reference signal appears at the beginning of each horizontal line. With this scheme, the PLL maintains good discipline with respect to its reference. The adopted video format in the U.S. allows for transmission of a short-burst signal (eight cycles) immediately after each horizontal sync pulse. However,

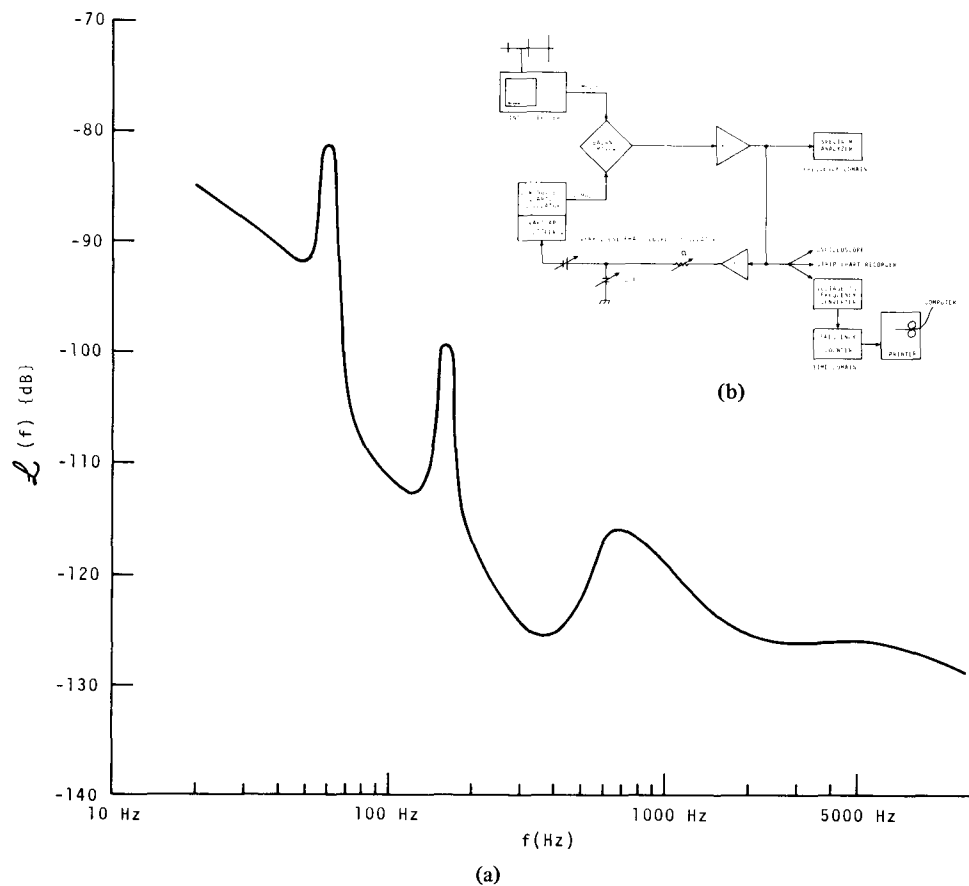

Note: 1) Test receiver bandwidth ~ 3 MHz; dead time = 3 ms.
 2) From $\tau = 1$ ms to 6 s, the $\sigma_f(\tau)$ data were derived from a computing counter with a quartz crystal reference ($\tau = 1$ ms \rightarrow 2 s, $N = 2$, averaging $10^4 \rightarrow 10$ sets); from $\tau = 6$ –600 s, $\sigma_f(\tau)$ measurements were taken with the instrumentation shown in Fig. 3(b) ($\tau \cong 6$ s \rightarrow 600 s, $N = 2$, averaging 6 sets, the measuring system bandwidth is ~ 30 Hz).

Fig. 8. (a) Noise spectral density of 1-MHz PLL locked to television network NBS signal. (b) Schematic for measuring noise spectral density.

for all purposes, any additional frequency information must be transmitted during the vertical interval, which means the sample rate for a remote PLL is necessarily 60 Hz for such a signal. The fact that a vertical interval signal appears only once per field will govern to a noticeable degree the short-term stability of a PLL.

Measurements of long-term stability (in this case, greater than 6 s) were made by beating the frequency of the oscillator against a reference and observing points of zero crossing of the beat note. The reference was offset so that zero crossings occur with a regularity that reveals best the statistics of interest. The reference used was a quartz oscillator in a controlled environment. Knowledge is available about the performance of the quartz oscillator; thus, it becomes a simple task to subtract its noise from the total. Referring to Fig. 7(b), the output of the balanced mixer is fed to a circuit that senses signal zero crossings, which in turn commands a paper tape punch to record the time of the zero crossing. This record is processed by computer and a plot of σ_f in the time domain is calculated (σ_f versus τ). The bandwidth of the apparatus was ~ 30 Hz; zero crossings of the beat note occurred about once every 6 s. The results of this procedure have been added

to the plot shown in Fig. 7(a). Note that after 15 min, σ_f has reached almost 1×10^{-11} .

Data taken of color subcarrier stability for comparison to the line-1 active system have been included; both deal with the transmission of frequency information via television. From data using the TV color subcarrier as a frequency reference for a remote location (New York City to Boulder), statistical analyses done by Allan yield the following relations:

$$\sigma_f(\tau) = \frac{10^{-9} \text{ s}}{\tau}, \quad \tau < 10 \text{ s}$$

$$\sigma_f(\tau) = (3.5 \times 10^{-10} \text{ s}^{2/3}) \tau^{-2/3}, \quad 10 \text{ s} \leq \tau \leq 1000 \text{ s},$$

where σ_f is a statistical measure of frequency stability averaged over a time τ in seconds [5]. This function has been plotted on the graphs of Fig. 7(a) for comparison. The color subcarrier stability for $\tau = 15$ min using this formula yields σ (15 min) = 4×10^{-12} . This is roughly a factor of two better than the active line-1 method.

Further aspects of short-term stability can be seen by measuring the frequency spectrum of the decoder's locked oscillator. The technique that is illustrated in Fig. 8(b) involves some-

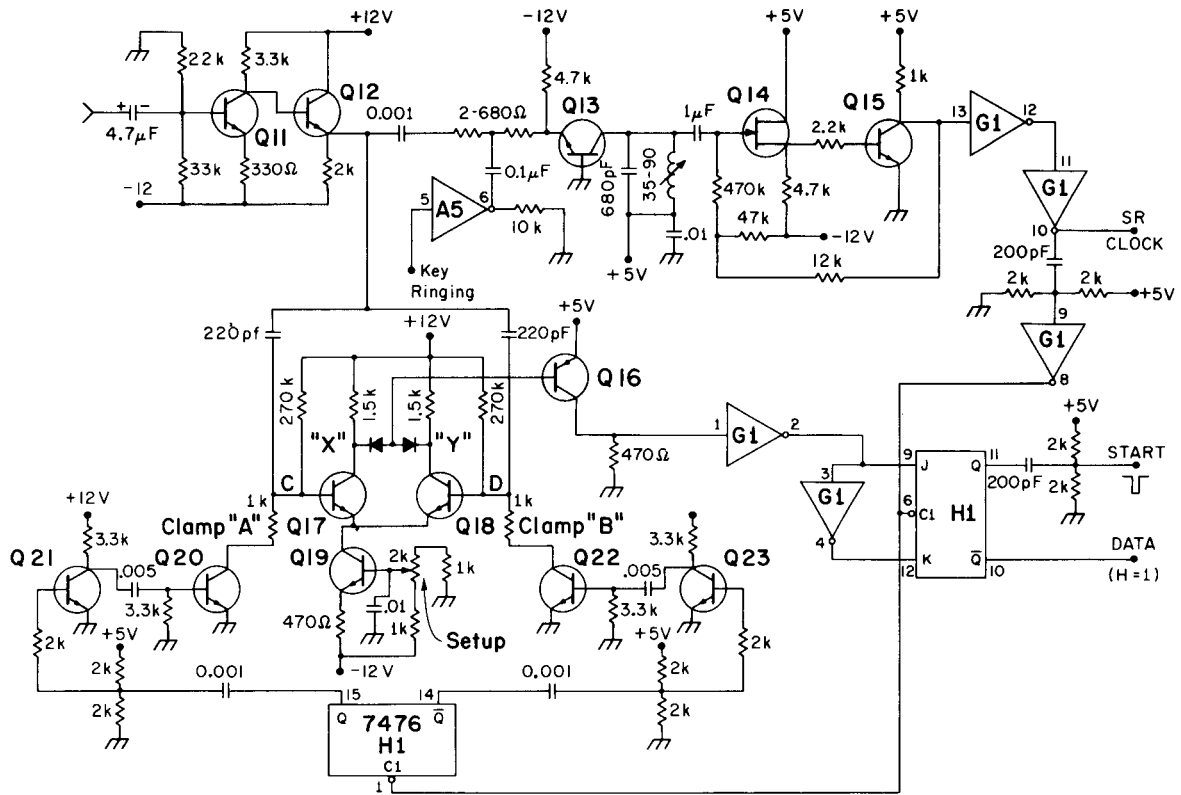

(a)

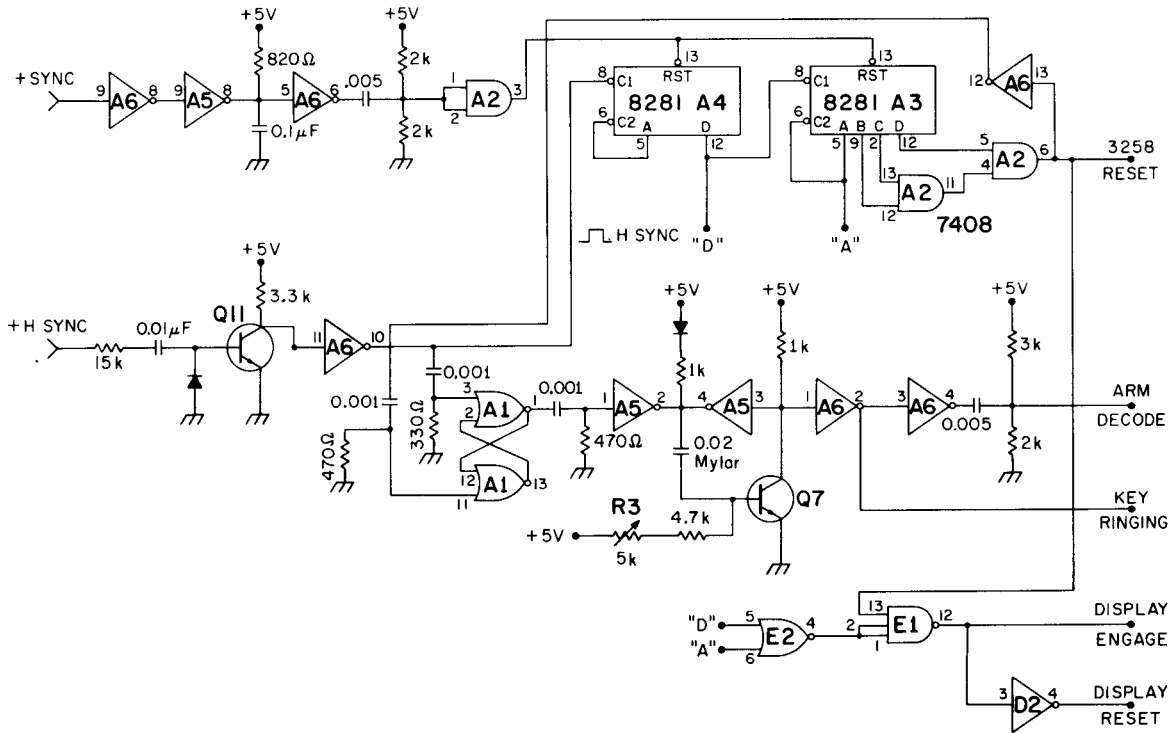

(b)

Fig. 9. (a) Schematic of time-of-day demodulator that will convert NBS line-1 NRZ time code to serial BCD data. (b) Television raster line count and control for demodulator.

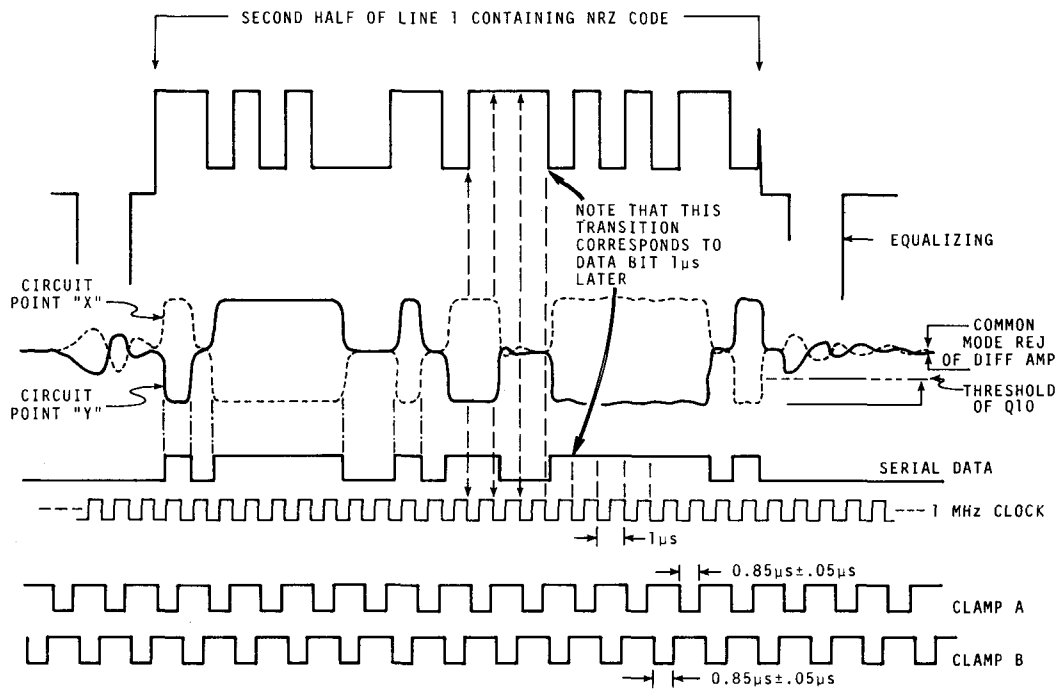

Fig. 10. Waveform diagram indicating the action of demodulator on typical NRZ code.

thing similar to that mentioned previously except that the reference oscillator is loosely locked to the oscillator under test, and the output of the balanced mixer, amplified and recorded, represents the noise density in the frequency domain. In theory, since the loop has a long time constant, fast random fluctuations of the oscillator under test are not corrected by the loop, so these short-term phase instabilities can readily be measured from the output of the mixer.

Fig. 8(a) shows the power spectral density data. $L(f)$ is a frequency domain measure of phase fluctuations (noise, instability, modulation), which is defined as the ratio of the power in one phase noise sideband, referred to the input carrier frequency on a per hertz of bandwidth spectral density basis, to the total signal power at Fourier frequency f from the carrier. The receiver-site reference oscillator exhibited spectral data better than 20 dB below the data of Fig. 8(a); thus, the measure of the total phase fluctuations are derived essentially from the 1-MHz PLL under test. Three resonances appear at 60, 164, and 640 Hz. The resonance at 60 Hz is most likely a result of the PLL sample rate and small traces of hum. No attempt will be made to analyze the other resonances except to say that they, too, are probably the result of some aspect of the PLL sample rate.

VII. DEMODULATOR

It is best that the reader review the description of the television-time code format given in Section III before going on to the discussion that follows. Fig. 9(a) is a schematic of a low-cost demodulator.

Demodulation of the time-code signal requires that one inspect the state of the incoming code once every $1 \mu\text{s}$. Since the demodulator must be phase coherent, or in step, with the modulator (TCG) 1 MHz, it is necessary that the demodulator

have a reference 1 MHz. A 1-MHz burst signal that is $22 \mu\text{s}$ long occurs before the NRZ time code. This signal may be used to excite a resonant tank circuit that will sustain the 1-MHz signal for the duration of the time code and provide a suitable reference for coherent demodulation.

From the television receiver's detector, a video signal with negative-going sync is fed to amplifier $Q11$ whose output is coupled to $Q12$, which is in an emitter-follower configuration. At this point, the signal splits to two principal circuits: 1) the 1-MHz ring tank, and 2) the coherent detector. $Q13$ in grounded-base configuration provides high impedance drive for the tank with inverter $A5$ acting as a signal switch. The video signal is enabled momentarily when line 1 is present; switch $A5$ is driven by a video raster line count. The tank circuit drives FET $Q14$, which in turn feeds $Q15$. A 12-k resistor from $Q15$ collector to bias resistors of $Q14$ gate provide negative feedback to compensate for level drift accompanying the 1-MHz ring. The output of $Q15$ is coupled to inverter $G1$, which thus furnishes clocking for the data-shift register. Coherent switching of the NRZ demodulator comes from the shift register clock; however, the switching transitions are delayed through a differentiator with $t_c \approx 200 \text{ ns}$.

Coherent 1-MHz appears at JK 7476 clock input whose output causes alternate $2\text{-}\mu\text{s}$ clamping of the inputs of differential amplifier $Q17/Q18$. Also, both inputs of the differential amplifier are coupled to the output of the video amplifier $Q12$. If video is at any steady level, then circuit points X and Y will reset at equal potentials (high). If there is a transition in video immediately prior to clamp A or B , then $Q17$ or $Q18$ will clamp to a new, slightly different value and the next alternate clamp generates an imbalance between points X and Y . Transistor $Q16$ detects when X or Y is low and feeds inverter $G1$. Recalling that with NRZ modulation, transitions corre-

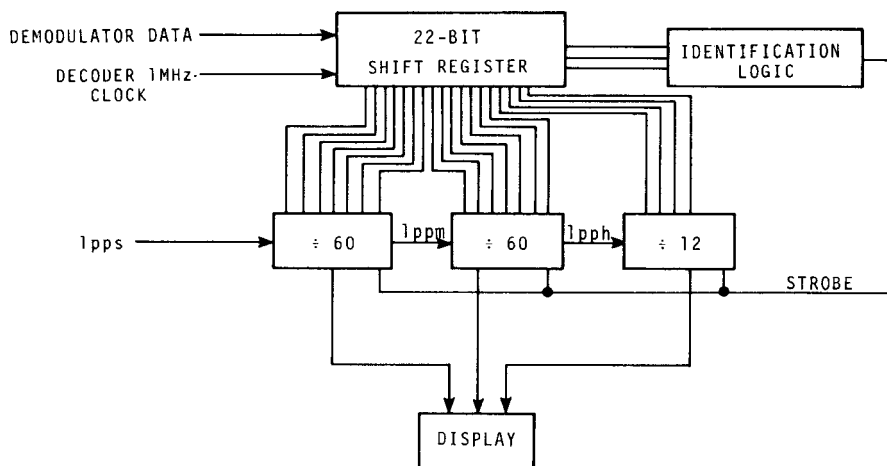

Fig. 11. Block diagram of a digital clock that may be interconnected to active TV line-1 demodulator.

spond to data bits, one now has a bit-by-bit serial code at $G1-G2$. The first instant that ($G1-2$) goes high, the Q output of JK 7476 will go high at the next negative-going transition of the 1 MHz and trigger a start signal whose principal function is to prepare other circuitry for decoding. The Q output yields the serial data ($H = 1$) with a 1-MHz bit rate.

Using an oscilloscope with line-1 trigger (key ringing may be used), the 2-k setup resistor should be adjusted so that the waveform at $G1-2$ looks similar to the serial data illustrated in Fig. 10 when the TV receiver is tuned to a station having the time code. Amplitude of video at points C and D should be about 1 V peak to peak. If it is not, the gain of $Q11$ may be changed slightly by altering resistance values.

VIII. LINE COUNT AND CONTROL

The purpose of this portion of the circuit [Fig. 9(b)] is to synchronize events occurring in the decoder with the television raster. Composite sync from the TV receiver is fed to inverter $A6$, which feeds an integrator with a long enough time constant to identify the vertical serrations. This vertical sync signal is used to reset a $\div 256$ counter consisting of two 8281's. The divider chain, since it is clocked by horizontal sync from the TV receiver, acts as a video line counter. At the 256th line $A2-6$ goes low and causes $R-S$ flip-flop $A1$ to change states until the next horizontal line (257). This change of state triggers a one shot comprised of $A5$ and $Q7$, which delay decoding until line 262½, approximately 400 μ s later. At this point, a complete field of video has been received, and the arm decode pulse is now synchronous with line 1 of the next field. Line-1 sync enables the decoding function and starts the key ringing for the 1-MHz resonant tank circuit.

IX. UPDATING A DIGITAL CLOCK

The demodulator provides serial data as well as clocking to be used in conjunction with a 22-bit serial-in/parallel-out shift register. The parallel data may be used to update a digital clock's major divider chain, or a reset pulse can be derived for use in zeroing a face clock. Fig. 11 is a block diagram of a digital clock with shift register. The first three bits are used

to identify the hours-minutes-seconds data; correct identification initiates a strobe that loads the contents of the shift register into the clock. Digital clocks with serial-in data shift registers are available from several manufacturers with a choice of methods of display.

X. CONCLUSION

The NBS has been concerned for a long time with the public's need for accurate time-of-day and frequency information. Its WWV, WWVH, and WWVB time and frequency broadcasts are familiar to many people. Expanding technology in all facets has tested and found many times that these services were limited; it has become increasingly important that better methods be adopted. With time-code generators installed at the television network centers in New York City and Los Angeles, it is estimated that 70 percent of the United States' population could be reached using an active TV system. Since the means of distribution already exists, implementation of the system appears to be relatively inexpensive.

The line-1 frequency-transfer capability has been compared with that employed by the television network for color demodulation; i.e., 3.57 . . . MHz colorburst reference. Measurements show that the active system's 1-MHz PLL is very nearly as stable as a color receiver's 3.57 . . . MHz PLL. This is a gratifying result in light of the fact that the line-1 system's sampling time for a PLL is about 1/100 that of a colorburst PLL. (Recall that the 3.57 . . . MHz burst reference appears at the beginning of every horizontal line of video.) An important consideration is that, an active system makes available the reference frequency regardless of network programming whereas locking a 3.57 . . . MHz PLL is advantageous only when the program is 1) in color, and 2) deriving its burst from a rubidium-controlled synthesizer. Videotape replays, commercial breaks, black-and-white programs, or short inserts, etc., limit the ability to average for more than just a few minutes. A network active system, on the other hand, is only upset by local affiliate programming; for many periods of time, this is limited to station breaks and local commercials that usually occur once each half hour.

With respect to date synchronization, an active TV system is as good as any of the passive systems employing a method of video line identification for a time-transfer reference. The passive line-10 identification technique has experienced great popularity since its inception in the late 1960's [1]-[3], [12]-[14]. It has been compared to the most sophisticated methods of time and frequency dissemination available today [5]. An active TV time system offers all of the precision of the line-10 identification method while allowing much greater ease of use.

This experiment has shown that an active television-code technique is feasible when used in conjunction with network broadcasts. The cost and complexity of decoding equipment is not great in comparison with other dissemination methods encompassing nationwide coverage, and we believe its usefulness would extend to low, intermediate, and high-accuracy users. Furthermore, continuing research by industry in the field of large-scale integrated circuits (chips) not only can make it possible to reduce costs for a decoder by a considerable amount, but also can make possible the inauguration of other services by the networks and affiliates, such as message communications to viewers and network or channel identification for automatic television receiver tuning. As an example, captions accompanying on-the-air programs have proved to be an effective aid to the hard of hearing. With the displayed words appearing at the bottom on the viewer's television screen, NBS TV time equipment was used for a captioning demonstration before an audience of hearing-impaired individuals (Washington, D.C., February 15, 1972).

To summarize, we will note some of the observed advantages and limitations of the experimental active TV method.

A. Advantages

- 1) Measurements and reduction of data are fast and simple.
- 2) It combines the precision of line-10 time synchronization with that of subcarrier frequency-transfer capability obtainable during network colorcasts.
- 3) User cost is proportional to degree of precision required.
- 4) For date information, the system is unambiguous to 24 hours with reliability to 10 μ s.
- 5) Since there are several dissimilar networks, atomic clock references for each provide redundancy and cross comparison of data.
- 6) Some network path changes are predictable; all are logged and accounted for and may be published afterwards.

B. Limitations

- 1) Microwave network paths can be interrupted without notice.
- 2) There is limited viewing time of nationwide network programs.

3) System will not work with tape delays without the use of special equipment program, or at least line 1, must be live for measurements to be referred to the cesium atomic standard.

4) Propagation anomalies may limit the system's usefulness in some areas of the United States.

ACKNOWLEDGMENT

The author wishes to thank J. H. Shoaf, D. W. Allan, and E. Gray of the Atomic Frequency and Time Standards Section of the NBS for their valuable guidance and assistance with respect to all measurements completed and put forth in this paper. He also wishes to thank J. Marshall of Hewlett-Packard, Santa Clara, Calif., for his monitoring of the code on the West Coast network. We are deeply grateful for the cooperation and technical aid obtained during this test from the American Broadcasting Company's television network (main studios, WABC, New York City, and KABC, Los Angeles) and its affiliates with special thanks to KBTW, Denver.

He would like to extend deep appreciation to D. D. Davis, engineering developer of the active TV time system, whose technical skill and patient counsel have meant for him very valuable training and inspiration.

REFERENCES

- [1] D. D. Davis, B. E. Blair, and J. F. Barnaba, "Long-term continental U.S. timing system via television networks," *IEEE Spectrum*, vol. 8, pp. 41-52, Aug. 1971.
- [2] J. D. Lavanceau and D. Carroll, "Real time synchronization via passive television transmission," in *Proc. 3rd Ann. Precise Time and Time Interval (PTTI) Strategic Planning Meeting*, vol. 1, (Washington, D.C., Nov. 16-18, 1971), to be published.
- [3] S. Leschiutta, "Long term accuracy of time comparisons via TV radio links," presented at the 25th Ann. Freq. Control Symp., Fort Monmouth, N.J., Apr. 1971.
- [4] D. D. Davis, "Frequency standard hides in every color TV set," *Electronics*, pp. 96-98, May 1971.
- [5] D. W. Allan, B. E. Blair, D. D. Davis, and H. E. Machlan, "Precision and accuracy of remote synchronization via network television broadcasts, Loran-C, and portable clocks," *Metrologia*, vol. 8, Apr. 1972.
- [6] D. D. Davis, James L. Jespersen, and G. Kamas, "The use of television signals for time and frequency dissemination," *Proc. IEEE (Lett.)*, vol. 58, pp. 931-933, June 1970.
- [7] F. K. Koide and E. J. Vignone, "TV time synchronization in the western U.S.," *Electron. Instrum. Dig.*, PMA Section, vol. 7, pp. 26-31, Oct. 1971.
- [8] D. A. Howe, "Results of active line-1 TV timing," *Proc. IEEE (Lett.)*, vol. 60, pp. 634-637, May 1972.
- [9] D. W. Allan, "Statistics of atomic frequency standards," *Proc. IEEE*, vol. 54, pp. 221-230, Feb. 1966.
- [10] J. A. Barnes, et al., "Characterization of frequency stability," *IEEE Trans. Instrum. Meas.*, vol. IM-20, pp. 105-120, May 1971.
- [11] J. A. Barnes, "Tables of bias functions, B_1 and B_2 , for variances based on finite samples of processes with power law spectral densities," NBS, Tech. Note 375, Jan. 1969.
- [12] J. Tolman, V. Ptáček, A. Souček, and R. Stecher, "Microsecond clock comparison by means of TV synchronizing pulses," *IEEE Trans. Instrum. Meas.*, vol. IM-16, pp. 247-254, Sept. 1967.
- [13] D. W. Allan, S. Leschiutta, and G. Rovera, "TV frame pulses used for precision time synchronization and their noise distribution," *Alta Freq.*, vol. 34 (English issue no. 2), p. 180E, Mar. 1970.
- [14] P. Parcelier, "Time synchronization by television," *IEEE Trans. Instrum. Meas.*, vol. IM-19, pp. 233-238, Nov. 1970.